

elektor electronics

leading the way

July/August 2004

£5.50

www.elektor-electronics.co.uk

PLUS!

MICRO WEB SERVER

TV Commercials
Killer



**SMALL
CIRCUITS
COLLECTION**

67

SNAPPY PROJECTS TIPS & IDEAS

Bumper Summer Issue 2004

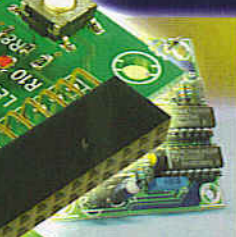
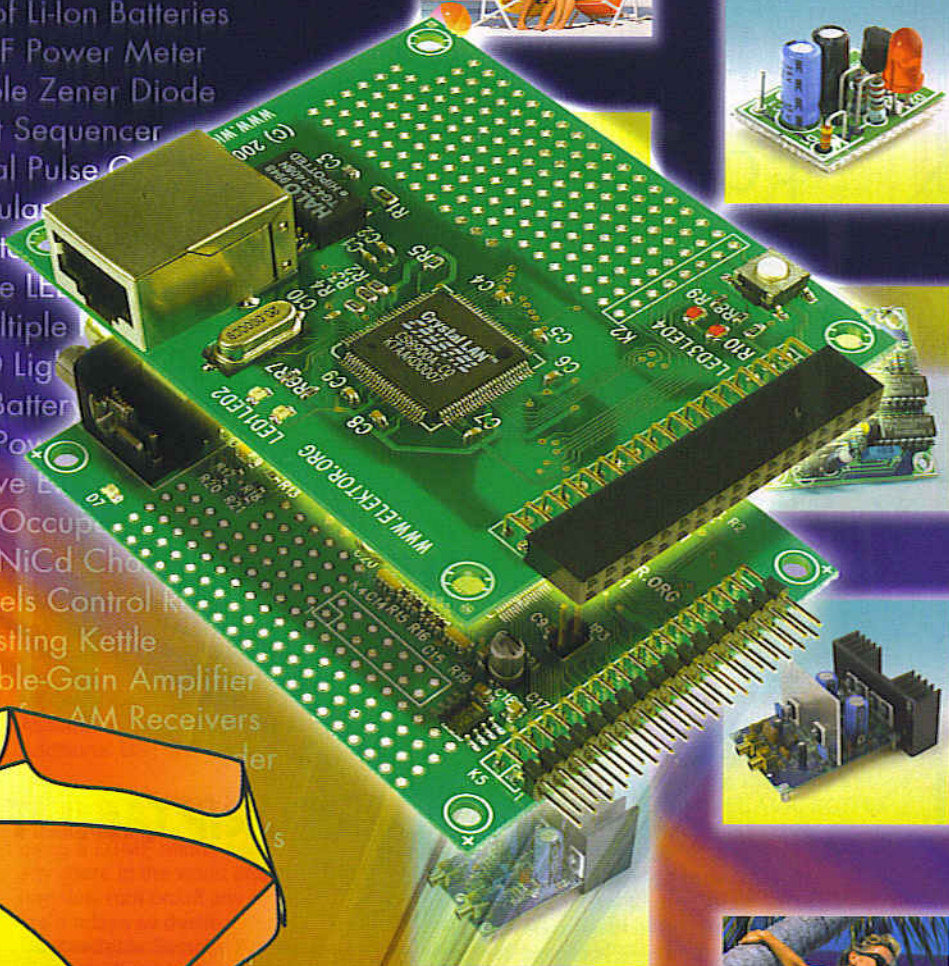
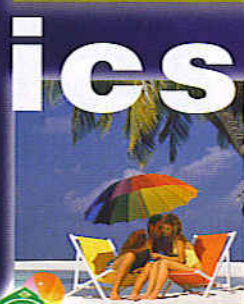

PAGM

The leaders in PIC development

FROM

£99

- ◆ All you need to get started with PIC
- ◆ Industry standard/quality board
- ◆ Open the box and get coding
- ◆ Available with C compiler or use our PicScript to write programs using simple commands...

**NO ASSEMBLER,
NO COMPILER,
JUST WRITE AND RUN**



EASE OF USE

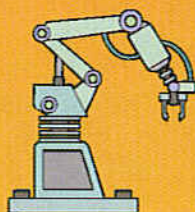

AUTOMATION



SCRIPTABILITY

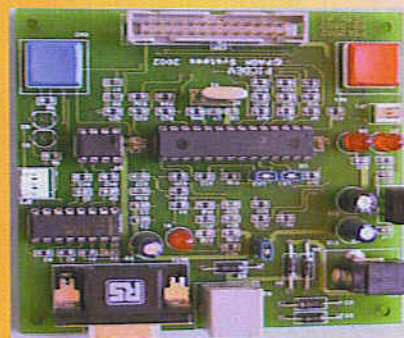

PicDev Board with PicScript

£99.00 (plus p+p)

This is a complete development suite for the novice or non programmer.

It is shipped with:

- PicDev Board
- PicShell and PicScript software
- Breakout board
- Cables
- Example scripts

PicDev Board with C Compiler

£165.00 (plus p+p)

This is a complete development suite for the more advanced programmer.

It is shipped with:

- PicDev Board
- PicShell and PicScript software
- C compiler
- Breakout board
- Cables
- Example scripts
- ICD1

Both items require

- PC with serial port available
- Power supply adapter

To order:

www.pagm.co.uk

sales@pagm.co.uk

Tel: +44 (0)1792 891927



Quasar Electronics Limited
PO Box 6935, Bishops Cleeve,
CM23 4WP
Tel: 0870 246 1826
Fax: 0870 460 1045
E-mail: sales@quasarelectronics.com

Add £2.95 P&P to all UK orders or 1st Class Recorded - £4.95,
Next Day (insured £250) - £7.95, Europe - £5.95, Rest of World - £9.95
(order online for reduced price UK Postage).
We accept all major credit/debit cards. Make cheques/PO's payable
to Quasar Electronics. Prices include 17.5% VAT.
Call now for our FREE CATALOGUE with details of over 300 kits,
projects, modules and publications.
MAIL ORDER ONLY.



QUASAR
electronics
Helping you make the right connections!

0871 CREDIT CARD SALES 717 7168

Motor Drivers/Controllers

Here are just a few of our controller and driver modules for AC, DC, unipolar/bipolar stepper motors and servo motors. See website for full details.

DC Motor Speed Controller (5A/100V)

Control the speed of almost any common DC motor rated up to 100V/5A. Pulse width modulation output for maximum motor torque at all speeds. Supply: 5-15VDC. Box supplied. Dimensions (mm): 60Wx100Lx60H. Kit Order Code: 3067KT - £12.95
Assembled Order Code: AS3067 - £19.95

NEW! PC / Standalone Unipolar Stepper Motor Driver

Drives any 5, 6 or 8-lead unipolar stepper motor rated up to 6 Amps max. Provides speed and direction control. Operates in stand-alone or PC-controlled mode. Up to six 3179 driver boards can be connected to a single parallel port. Supply: 9V DC. PCB: 80x50mm. Kit Order Code: 3179KT - £9.95
Assembled Order Code: AS3179 - £16.95



PC Controlled Dual Stepper Motor Driver

Independently control two unipolar stepper motors (each rated up to 3 Amps max.) using PC parallel port and software interface provided. Four digital inputs available for monitoring external switches and other inputs. Software provides three run modes and will half-step, single-step or manual-step motors. Complete unit neatly housed in an extended D-shell case. All components, case, documentation and software are supplied (stepper motors are NOT provided). Dimensions (mm): 55Wx70Lx15H. Kit Order Code: 3113KT - £15.95
Assembled Order Code: AS3113 - £24.95



NEW! Bi-Polar Stepper Motor Driver

Drive any bi-polar stepper motor using externally supplied 5V levels for stepping and direction control. These usually come from software running on a computer. Supply: 8-30V DC. PCB: 75x85mm. Kit Order Code: 3158KT - £12.95
Assembled Order Code: AS3158 - £26.95

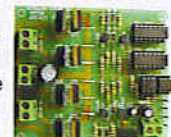

Most items are available in kit form (KT suffix) or assembled and ready for use (AS prefix).

Controllers & Loggers

Here are just a few of the controller and data acquisition and control units we have. See website for full details. Suitable PSU for all units: Order Code PSU445 £8.95

Rolling Code 4-Channel UHF Remote

State-of-the-Art. High security. 4 channels. Momentary or latching relay output. Range up to 40m. Up to 15 Tx's can be learnt by one Rx (kit includes one Tx but more available separately). 4 indicator LED's. Rx: PCB 77x85mm, 12VDC/6mA (standby). Two and Ten channel versions also available. Kit Order Code: 3180KT - £41.95
Assembled Order Code: AS3180 - £49.95



Computer Temperature Data Logger

4-channel temperature logger for serial port. °C or °F. Continuously logs up to 4 separate sensors located 200m+ from board. Wide range of free software applications for storing/using data. PCB just 38x38mm. Powered by PC. Includes one DS1820 sensor and four header cables. Kit Order Code: 3145KT - £19.95
Assembled Order Code: AS3145 - £26.95
Additional DS1820 Sensors - £3.95 each



NEW! DTMF Telephone Relay Switcher

Call your phone number using a DTMF phone from anywhere in the world and remotely turn on/off any of the 4 relays as desired. User settable Security Password, Anti-Tamper, Rings to Answer, Auto Hang-up and Lockout. Includes plastic case. 130x110x30mm. Power: 12VDC. Kit Order Code: 3140KT - £39.95
Assembled Order Code: AS3140 - £49.95



Serial Isolated I/O Module

PC controlled 8-Relay Board. 115/250V relay outputs and 4 isolated digital inputs. Useful in a variety of control and sensing applications. Uses PC serial port for programming (using our new Windows interface or batch files). Once programmed unit can operate without PC. Includes plastic case 130x100x30mm. Power Supply: 12VDC/500mA. Kit Order Code: 3108KT - £54.95
Assembled Order Code: AS3108 - £64.95



Infrared RC Relay Board

Individually control 12 on-board relays with included infrared remote control unit. Toggle or momentary. 15m+ range. 112x122mm. Supply: 12VDC/0.5A
Kit Order Code: 3142KT - £41.95
Assembled Order Code: AS3142 - £51.95

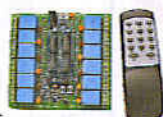

PIC & ATMEL Programmers

We have a wide range of low cost PIC and ATMEL Programmers. Complete range and documentation available from our web site.

Programmer Accessories:

40-pin Wide ZIF socket (ZIF40W) £15.00
18V DC Power supply (PSU010) £19.95
Leads: Parallel (LEAD108) £4.95 / Serial (LEAD76) £4.95 / USB (LEADUAB) £2.95

NEW! USB 'All-Flash' PIC Programmer

USB PIC programmer for all 'Flash' devices. No external power supply making it truly portable. Supplied with box and Windows Software. ZIF Socket and USB Plug A-B lead not incl. Kit Order Code: 3128KT - £29.95
Assembled Order Code: AS3128 - £39.95



Enhanced "PICALL" ISP PIC Programmer

Will program virtually ALL 8 to 40 pin PICs plus a range of ATMEL AVR, SCENIX SX and EEPROM 24C devices. Also supports In System Programming (ISP) for PIC and ATMEL AVRs. Free software. Blank chip auto detect for super fast bulk programming. Requires a 40-pin wide ZIF socket (not included). Available in assembled format only. Assembled Order Code: AS3144 - £54.95



ATMEL 89xxx Programmer

Uses serial port and any standard terminal comms program. 4 LED's display the status. ZIF sockets not included. Supply: 16-18VDC. Kit Order Code: 3123KT - £29.95
Assembled Order Code: AS3123 - £34.95



NEW! USB & Serial Port PIC Programmer

USB/Serial connection. Header cable for ICSP. Free Windows software. See website for PICs supported. ZIF Socket/USB Plug A-B lead extra. Supply: 18VDC. Kit Order Code: 3149KT - £29.95
Assembled Order Code: AS3149 - £44.95



www.quasarelectronics.com

Secure Online Ordering Facilities • Full Product Listing, Descriptions & Photos • Kit Documentation & Software Downloads



New CD-ROM Robotics

In Robotics, electronics meets information technology as well as mechanical engineering. The meeting results in a boundless experimental field. Do you want to explore it?

For beginners the shortest way is along the kits line, while experienced users and programmers are best served by DIY construction. Both options are available on this CD-ROM thanks to a large collection of datasheets, software tools, tips en tricks, addresses, Internet links to assorted robot constructions and general technical information. All aspects of modern robotics are covered, from sensors to motors, mechanical parts to microcontrollers, not forgetting matching programming tools and libraries for signal processing. Robots built from LEGO® bricks also get a fair amount of attention.

RRP £12.05
(US\$ 21.25)



Enter the fascinating world of robotics!

Order now using the Order Form in the Readers Services section in this issue.

Elektor Electronics (Publishing)
P.O. Box 190
Tunbridge Wells TN5 7WY England
Telephone +44 (0) 1580 200 657
Fax +44 (0) 1580 200 616

See also
www.elektor-electronics.co.uk

Summer Circuit Compilation Books

The 30x series of Summer Circuit compilation books have been bestsellers for many years. You can use these books not only for building the circuits described, but also as a treasure trove of ideas or circuit adaptations for your own experiments. Many readers have found in these books that new approach, new concept, or new circuit they were looking for. Not surprisingly, our 30x books are now firmly established as collector's items, and carefully preserved by thousands of professionals and hobbyists around the globe. Circuits and design ideas for: audio, video, music, car, bicycle, home, garden, games, radio, software, test and measurement, PC and peripherals, power supplies, computer hardware, and more.



367 pages
size 17 x 23.5 cm
ISBN 0-905705-66-1
RRP £18.20
(US\$ 37.00)



Complete your 30x circuits series now!

302 Circuits
354 pages, 14 x 21 cm
ISBN 0-905705-25-4
RRP £10.35 (US\$ 21.00)
304 Circuits
366 pages, 17 x 23.5 cm
ISBN 0-905705-34-3
RRP £13.45 (US\$ 27.00)
305 Circuits
369 pages, 17 x 23.5 cm
ISBN 0-905705-36-X
RRP £15.55 (US\$ 31.00)
307 Circuits
342 pages, 17 x 23.5 cm
ISBN 0-905705-62-9
RRP £18.20 (US\$ 37.00)

Order now using the Order Form in the Readers Services section in this issue.

Elektor Electronics (Publishing)
P.O. Box 190
Tunbridge Wells TN5 7WY England
Telephone +44 (0) 1580 200 657
Fax +44 (0) 1580 200 616

See also
www.elektor-electronics.co.uk

Pleased to meet you

As far as the Elektor Electronics editorial team is concerned, the Summer Circuits edition is special in that it represents a beginning as well as an end. We're done hoarding, writing and discussing the dozens of small circuits, design ideas and tips our readers have come to value so much over the past 30 years. At the same time, we launch a fresh hunt for items to go in next year's issue. As is made abundantly clear by this month's front cover, it's also the time when we start thinking of taking a holiday!

Although the photograph suggests the team is about to depart for a sun-drenched and possibly electronics-free destination, it was actually taken

when we still had a lot of articles to write and make sure this extra-thick issue could be printed. Whatever the workload ahead of us at the time, once our photographer was happy we enjoyed drinks on a nearby terrace. Apart from the usual office chitchat, the drinks did not fail to generate some really unusual circuit ideas. I would be very surprised if these did not make it into print some time.



Happy reading from all of us at Elektor Electronics!

Jan Buiting, Editor



Volume 30, Number 334, July/August 2004 ISSN 0268/4519

Elektor Electronics aims at inspiring people to master electronics at any personal level by presenting construction projects and spotting developments in electronics and information technology.

Elektor Electronics is produced and published by Elektor Electronics (Publishing), P.O. Box 190, Tunbridge Wells TN15 7WY, England. Tel.: (+44) (0)1580 200657, fax: (+44) (0)1580 200616. Email: sales@elektor-electronics.co.uk

The magazine is available from newsagents, bookshops and electronics retail outlets, or on subscription.

Elektor Electronics is published 11 times a year with a double issue for July & August.

Under the name *Elektor* and *Elektuur*, the magazine is also published in French, German and Dutch. Together with franchised editions the magazine is on circulation in more than 50 countries.

International Editor: Mat Heffels

Editor: Jan Buiting (editor@elektor-electronics.co.uk)

International editorial staff: Harry Baggen, David Daamen, Rolf Gerstendorf, Ernst Krempelsauer, Guy Raedersdorf.

Design staff: Karel Walraven (head of design), Ton Giesberts, Paul Goossens, Luc Lemmens (techdept@segment.nl)

Editorial secretariat: Hedwig Hennekens (secretariaat@segment.nl)

Graphic design / DTP: Ton Gulikers, Giel Dols

Managing Director / Publisher: Paul Snackers

Circulation Control: Margriet Debeij (m.debeij@segment.nl)

Subscriptions

Worldwide Subscription Service Ltd., Unit 4, Gibbs Reed Farm, Pashley Road, Ticehurst TN5 7HE, England. Telephone: (+44) (0)1580 200657, Fax: (+44) (0)1580 200616. Email: wwss@wwss.demon.co.uk. Rates and terms are given on the Subscription Order Form

Head Office:

Segment b.v. P.O. Box 75 NL-6190-AB Beek The Netherlands. Telephone: (+31) 46 4389444, Fax: (+31) 46 4370161

Distribution: Seymour, 86 Newman Street, London W1P 3LD, England

UK Advertising

Bernard Hubbard, 3 Crescent Terrace, Cheltenham GL50 3PE, England. Telephone (+44) (0)1242 510760, Fax: (+44) (0)1242 226626. Email: bernardhubbard@ukonline.co.uk. Advertising rates and terms available on request.

International Advertising

Klaas Caldenhoven, address as Head Office. Email: advertenties@elektuur.nl. Advertising rates and terms available on request.

Copyright notice

The circuits described in this magazine are for domestic use only. All drawings, photographs, printed circuit board layouts and article texts published in the editorial section of the magazine are copyright Segment b.v. and may not be reproduced or transmitted in any form or by any means, including photocopying, scanning or recording, in whole or in part without prior written permission from the Publishers. Such written permission must also be obtained before any part of this publication is stored in a retrieval system of any nature.

Patent protection may exist in respect of circuits, devices, components etc. described in this magazine. The Publisher does not accept responsibility for failing to identify such patent(s) or other protection.

The submission of designs or articles implies permission to the Publishers to alter the text and design, and to use the contents in other Segment publications and activities. The Publishers cannot guarantee to return any material submitted to them.

© Segment b.v. 2004

Printed in the Netherlands



12 Micro Webserver

Remote measurement and control is possible via the Internet. Unfortunately, webserver usually sit in large, humming grey cabinets. That's not the ideal solution for keeping an eye on your refrigerator, coffee machine or central heating system. The Elektor Electronics Micro Webserver provides an alternative. It's versatile, fast, small, and easy to build, and what's more, it provides super performance.

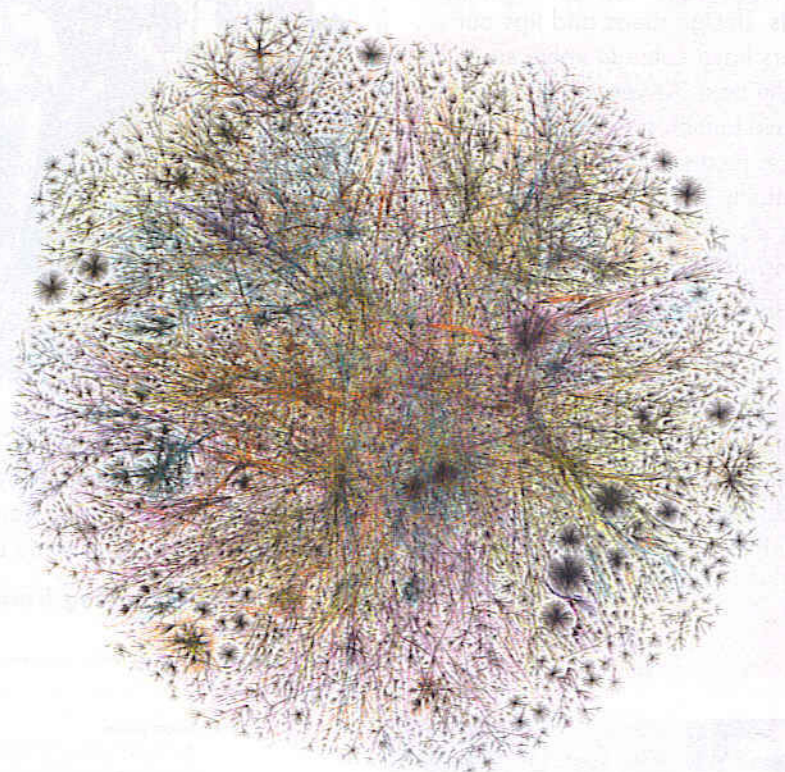

20 TV Commercials Killer

Stop those annoying advertisement breaks spoiling your recordings with this ingenious circuit. Its basic ingredients are an overclocked Scenix SX28 microcontroller running some clever software, fast static RAM and a two-way 'code learning' infrared remote control that obviates surgery to the family's precious VCR. Curious about the operation? Read on...

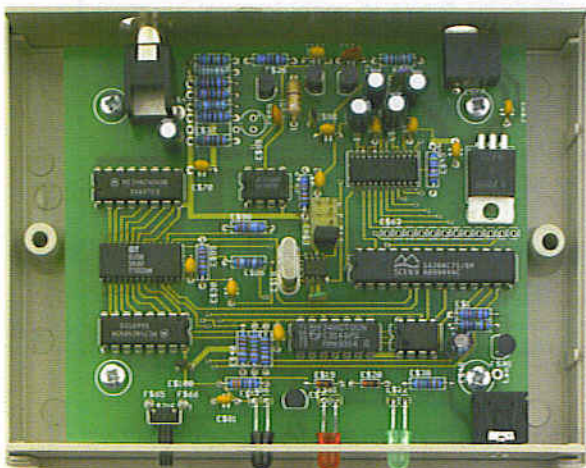

82 Light Sensor Technology

Light-sensitive sensors with characteristics similar to those of the human eye are most often implemented using photoresistors or special (and thus expensive) photosensors. Few people realise that normal LEDs can also be used as optical sensors that respond the same as the human eye.

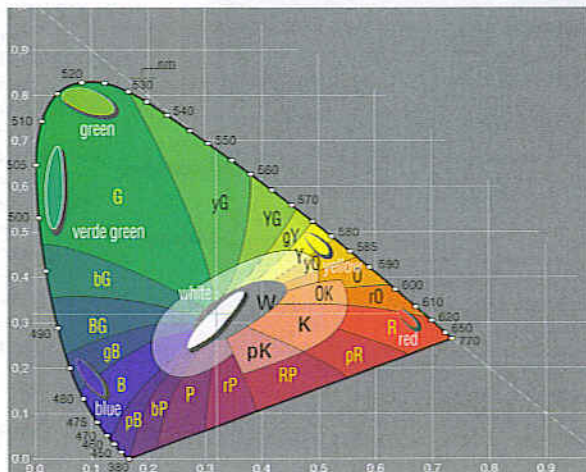

SMALL CIRCUITS COLLECTION

Bold article title = includes PCB layout

100 V Regulators	36	Relay Coil Energy Saver	72
3.3 V or 5 V Direct from the Mains	41	Reset from Multiple Power Supplies	47
Acoustic Sensor	79	Reset IC with Selectable Voltages	39
Adjustable Zener Diode	43	Reset Sequencer	44
Airflow Monitor	32	Save Energy	50
Blinker Indicator	62	Servo Tester using a 4538	64
Bluish Flasher	74	Shortwave Monitor	72
Buck/Boost Voltage Converter	60	Simple Darkness Activated Alarm	33
CMOS Crystal Frequency Multiplier	34	Simple Infrared Control Extender	56
Codec Complete	67	Simple NiCd Charger	51
Digital Isolation up to 100 MBit/s	58	Single-Chip VHF RF Preamp	66
Doorbell Cascade	35	SMPSU with a Relay	36
The Eternal 555	39	Solar-Powered High Efficiency Charger	64
Gated Alarm	44	SSB Add-On for AM Receivers	56
Home Network for ADSL	81	Stable Zener Reference	77
Inductorless 3-to-5 Volts Converter	76	Steam Whistle	66
Intelligent Flickering Light	38	Stepper Motor Generator	37
Irregular Flasher	46	Storage Battery Exerciser	48
LED Light Pen	48	Switchless NiCd/NiMH Charger	35
Lifespan of Li-Ion Batteries	42	Triple Power supply	49
Linear RF Power Meter	42	Tuned Radio Frequency (TRF) Receiver	76
Long-Interval Pulse Generator	45	Two-LED Voltage Indicator	73
Luxury Car Interior Light	53	USB Converter Controlled via HTML	65
Mains Failure Alarm	70	UV Torch Light	62
Mains Voltage Monitor	61	Very Low Power 32-kHz Oscillator	74
Master/Slave Switch	75	Voltage Levels Control Relays	52
Meter Adapter with Symmetrical Input	71	Whistling Kettle	54
Monitor Life Xtender	40	White LED Lamp	46
Motor Turn/Stall Detector	63	Xilinx JTAG Interface	79
One Component Oscillator		Xport	80
for 1 to 10 MHz	58	You have Mail!	57
Power Flip-Flop Using a Triac	59	Zero Gain Mod	
Programmable-Gain Amplifier	55	for Non-Inverting Opamp	33
Pseudo Track Occupancy Detector	50		
Push Off / Push On	70		
PWM Modulator	78		

*More Small Circuits in
the December 2004 issue!*

32-81 Small Circuits Collection

Construction Projects

- 12** Micro Webserver
- 20** TV Commercials Killer
- 88** IR Servo Motor Interface for RCX
- 96** R/C Analyser
- 102** Canon EOS Cameras go Wireless
- 116** Electronic Switch for Modellers

Informative Articles

- 28** Measurement and Control via the Internet
- 82** Light Sensor Technology
- 106** MAX6954 Display Driver
- 110** Battery Polarity Protection
- 112** Working with ActiveX
- 120** Tomi Engdahl,
the man behind Epanorama.net

Regulars

- 5** Foreword & Colophon
- 8** News & New Products
- 119** Mailbox
- 122** Electrical Safety page
- 124** EMC page
- 129** Readers Services
- 131** PCB Layouts
- 132** Sneak Preview
- 132** Index of Advertisers

82

Canon EOS Cameras go Wireless

Sure, RF Remote control is desirable if you're into aerial, wildlife, candid or physically dangerous photography, but prepare for a shock if you shop around for commercially available remote controls. Rajkumar Sharmar has an alternative for you.

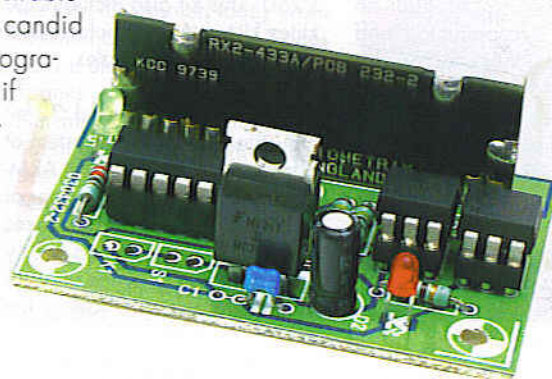

Low-cost ARM-7 kits from Hitex

Capitalising on the success of the Keil/Philips LPC900 8051 kits (see *Elektor Summer 2003 Edition*) Hitex UK has announced the Keil/Philips LPC2100 ARM-7 kits at £75. This is a remarkable price for a remarkable ARM kit.

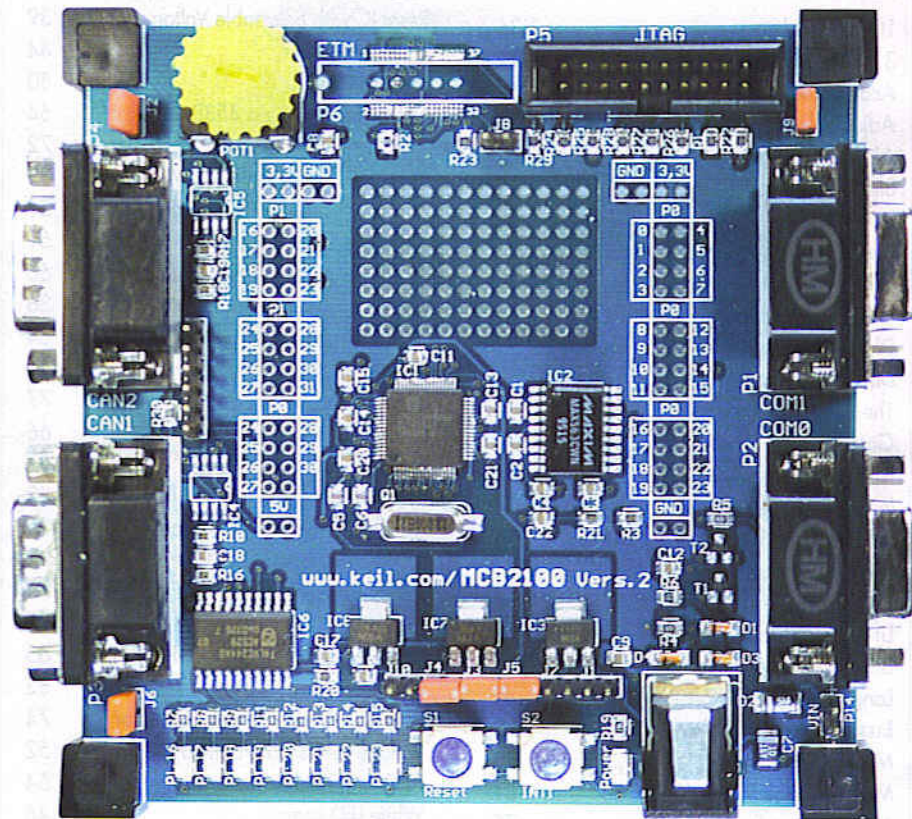

ARM is the 32-bit IP core that is sweeping the 32-bit world like the 8051 did in the 8-bit world. Whilst the ARM core is not new, it has previously only been used as a core in ASICs and specialist parts, Philips have now released stand-alone ARM7 MCUs. The ARM LPC2100 range is designed to take over where the 8051 based LPC900 range leave off. In order to keep this transition as smooth as possible Philips are using the familiar Keil uVision3 system for both the LPC2100 and LPC900 development.

The basic LPC2100 kit contains the board and the Keil development package. The board sports an LPC2129 part with 16 kB RAM 256 kB Flash on board so no need of any additional memory. Code may run from either RAM or Flash. The LPC2129 has a wide range of peripherals on it including: ADC, GP-IO, I²C, UARTs, CAN, SPI, Capture/com-

pare, PWM, two timers and a real-time-clock/calendar. One of the UARTs has all the signals required for MODEM control. This range of peripherals makes for a powerful single chip system. The board has, of course, a row of LED's and the traditional Keil 'Blinky' application, a patch area, both serial and CAN network are connectors fitted. The board is tracked for expansion connectors for the GPIO.

Hitex has a range of working software examples for board that are available on their web site. There is a boot loader on the part so programming and booting via the serial port is workable. However, as with all ARM parts there is a JTAG interface and unique to Philips ARM-7 is Trace. Hitex have a range of JTAG debuggers starting from a parallel port wiggler £50 to the full industrial systems with trace costing a little more. Whilst on the subject of debug-

ging, the Keil development suite (uVision3) that comes with the kit has a full ARM-7 simulator. This is limited to 16 kB (but *not* time limited) and will be suitable for most modest applications. The part that is not limited however is the GNU C and C++ compiler suite that is part of the package. So you can build applications of any size with this kit. In addition to the full ARM simulation Keil have the JTAG-USB debugger called uLink. This is usually £215 but Hitex are offering a complete kit of the MCB2100 board with the Keil uLink debugger for £250. This kit also includes the Hitex Hi-top ARM simulator and the Hitex ARM examples.

This is a very powerful 32-bit industrial development system at a fraction of the cost. The ARM-7 parts are used in all manner of applications from set top boxes to medial systems and many mobile phones. As one industry commentator said ARM is the

8051 of the 32-bit world. Academics should contact Chris Hills as Hitex can do some very special arrangements for supplying complete ARM Development labs with sets of MCB2100 boards, JTAG debuggers and Keil development suites as well as a wealth of additional resources for special academic prices. Whilst the LPC900 kits are suitable for 6th form colleges upwards the ARM kits are more suitable for Universities.

**Hitex UK Ltd., Warwick University
Science Park, Coventry CV4 7EZ.
Tel +44 (0)24 7669 2066.
Internet: www.hitex.co.uk/arm.
Email: chills@hitex.co.uk**

(047120-1)

Enigma-E Kit hits Bletchley Park Museum

The Enigma-E developed by Dutchmen Marc Simons and Paul Reuvers is a DIY construction kit that enables you to build your own electronic variant of the famous Enigma coding machine that was used by the German army during World War 2.

The kit works just like a real Enigma and is compatible with an M3 and M4 Enigma as well as the standard Service Machines. A message encrypted on, say, a real Enigma M4 can be read on the Enigma-E and vice versa. The M4 (4-rotor) Enigma was used by the German Navy while the M3 version was the standard for the Luftwaffe and Ground Forces (Heer).

The makers

Paul Simons and Marc Reuvers run a microcontroller software company and are enthusiastic volunteers of the 'Jan Corver' Dutch Radio Amateur Museum near Eindhoven, the Netherlands. Marc and Paul are known for their brilliant, reverse-engineering and firmware conversions resulting in the re-use (by licensed radio amateurs) of ex-government surplus radio equipment (PMR), with the proceeds going to the Jan Corver Museum.

Enigma-E is yet another demonstration of Paul and Marc's ingenuity when it comes to translating concepts (this time, electromechanical encryption) into real electronics. This time, quite unexpectedly, the interest in their product was even greater in the UK than in their home country. Enigma-E is built around a PIC16F873 and runs software written by Marc using assembler rather than C or another high-level language in order to squeeze maximum functionality from the limited memory space available of just 4 kB Flash.

The kit

The kit comes complete with PCBs and all components, but

users will have to add a battery and make or purchase their own enclosure. A great example of how the Enigma-E electronics can be turned in a 'Secret Agent style' portable unit complete with operating instructions secured to the inside of the lid may be seen in the photograph. The plug-board, originally a 'military-only' add-on to the commercial Enigma machine, is mounted vertically.

The kit also comprises a 60+ page documentation package with lots of information not only on the construction of the double-sided and through-plated PCBs (and plans for the wooden case) but also on various design aspects and a small historical background to the Enigma machine.

According to software wizards Marc and Paul, building the kit isn't difficult, but requires basic soldering experience. If you haven't soldered for a long time, or if you're new to electronics, you might want to practice first on some old electronic circuits. Alternatively, you could try to find an electronic enthusiast near you and ask for help.

Bletchley Park

Bletchley Park was the place where during WW2 the German armed forces top secret codes used for radio communication were broken by a team of mathematicians (including Alan Turing and Dilly Knox), providing the Allies with vital information towards their war effort.

The world's first programmable computer (all valved and called Colossus) and other technologies we take for granted today were initiated at The National Codes Centre Bletchley Park.

Thanks to the efforts of the Bletchley Park Trust, the historic buildings were saved from demolition and the park converted into a museum. Bletchley Park now provides attractive weekday and weekend programmes, theme exhibitions, lectures and much more that make

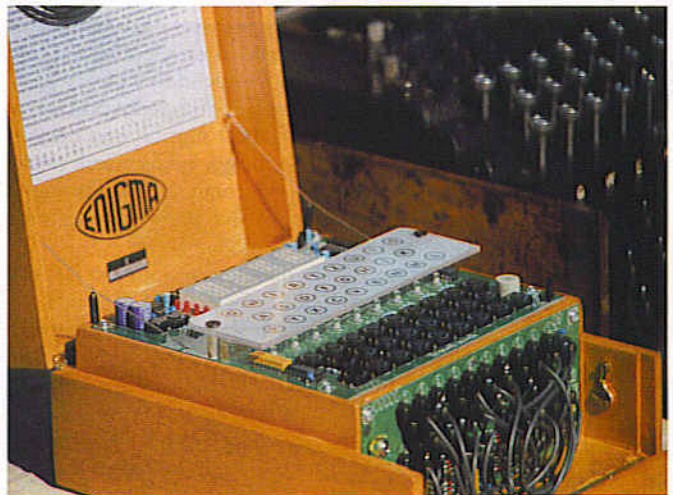

Enigma-E electronics housed in a beautifully tooled wooden case, with its electromechanical ancestor in the background.

an excellent day out for anyone, young and old, interested in cryptography, not necessarily within a historic framework. The Enigma-E Kit can be purchased at £119.99 in the Bletchley Park Shop.

(047122-1)

Web pointers

Enigma-E homepage:
www.xat.nl/enigma-e/

'Station X', the Bletchley Park Museum homepage:
www.bletchleypark.org.uk/

(left to right) Marc Simons, Paul Reuvers and Christine Large (MD, Bletchley Park), photographed (quite appropriately, we'd say) during the 'Wizards, Widgets and Weird Inventions' exhibition, at the same time celebrating the delivery the first batch of Enigma-E kits and a few demo units to the Museum.

Photograph: Dave Whitechurch, Bletchley Park Museum.



Ethernet enabled DOS controller

At only US\$ 98 per unit, JK microsystem's new picoFlash is a 186 compatible DOS computer with Ethernet whose performance rivals competitor's Ethernet-enabled products for a fraction of the cost.

Slightly larger than a credit card, the picoFlash is a fully programmable, compact single board computer ideally equipped for data acquisition, industrial control and communications applications. Standard units feature a fast, 40-MHz RDC R8822 microprocessor, NE2000 compatible Ethernet, 512 k DRAM and 512 k Flash memory, two serial ports, 16 bits of I/O, hardware clock/calendar and a socket to expand non-volatile memory using M-systems DiskOnChip products. The preloaded royalty-free DOS operating system and Flash file system provide a fast

yet convenient environment for embedded development. Along with a watchdog timer, 5-V DC power, RS485 serial port capability, LCD support and aggressive pricing, the picoFlash single-board computer covers many embedded Ethernet designs for the OEM market.

Available development kits are US\$ 219 and include a picoFlash controller, necessary cables, Borland C/C++ version 4.52 compiler, driver libraries and documentation. Free technical support from JK microsystems' engineers is available via email or the new online Support Forums at <http://forums.jkmicro.com>

JK microsystems, Inc.,
1403 5th St. Suite D, Davis, CA
95616, USA.

Internet: www.jkmicro.com

(047076-3)

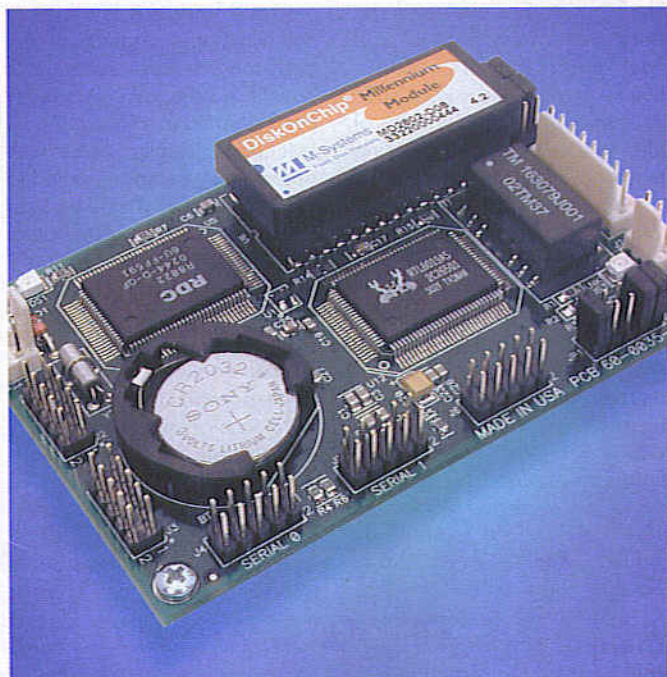

Two into one does go

Alphasense claims to have introduced the smallest two-gas electrochemical sensor, onto the world market.

The D2 dual Carbon Monoxide and Hydrogen Sulfide sensor represents a significant development of the established "D" Family of sensors.

The D2 size, measuring only 14.5 mm (diameter) by 11.5 mm (height), encloses the companies well-proven electrochemical technology for both CO and H₂S measurement. The design of this miniature sensor ensures that the CO measurement is not influ-

enced by the presence of H₂S in either the atmosphere being monitored, or in multi-component calibration gas mixtures.

The advance made by Alphasense in sensor packaging provides Original Equipment Manufacturers (OEMs) with the opportunity to design lighter and smaller multigas instrumentation, now being demanded by users. A further major advantage for volume instrument manufacturers, is a significant reduction in the cost per measured gas provided by the D2 dual gas sensor.

The 'D Family' continues to grow

— not just with the introduction of this unique dual gas sensor, but also by two additional single gas versions. Both Chlorine and Nitrogen Dioxide are now available in this miniature size, adding to Carbon Monoxide and Hydrogen Sulfide, with more sensor types planned over the coming year, giving OEMs the ability to further reduce size and price for their next generation of instruments.

Alphasense Ltd., Oak Industrial Park,
Great Dunmow, Essex CM6 1XN.
Tel: + 44 (0) 1371 87 80 48,



fax: + 44 (0) 1371 87 80 66.
Internet: www.alphasense.com

(047076-4)

The internet site for all professionals and hobbyists
actively engaged in electronics and computer technology

www.elektor-electronics.co.uk

Smaller, low-current SPI serial EEPROMs

Microchip's 8-Kbit 25XX080A/B and 16-Kbit 25XX160A/B are SPI bus-compatible serial EEPROM devices with a maximum clock speed of 10 MHz, a write time of 5 milliseconds, and a write current of 3 milliamps. These devices all feature self-timed ERASE and WRITE cycles, built-in write protection, and high reliability with 200-year data retention and one million erase/write cycles. They are available in small packages, such as the MSOP, alongside standard packages including TSSOP, PDIP and SOIC.

The 25XX080A/B and 25XX160A/B are available in two voltage ranges ("AA" in 25AA080B denotes 1.8 - 5.5V and "LC" in 25LC080B denotes 2.5 - 5.5V). Both industrial temper-

ature grade (-40°C to +85°C), and extended temperature grade (-40°C to +125°C) devices are available. In addition, both 16- and 32-byte page sizes are available. The 'A' versions (25LC080A and 25LC160A) feature 16-byte page size, while the 'B' versions (25LC080B and 25LC160B) feature 32-byte page size.

Microchip's SEEVAL® 32 Serial EEPROM Designer's Kit supports these new devices assisting system integration and hardware/software debug.

**Arizona Microchip Technology Ltd.,
Microchip House, 505 Ekdale Road,
Winnersh Triangle, Wokingham RG41
5TU. Tel. (+44) (0)118 921 5858.
Fax (+44) (0)118 921 5835.
www.microchip.com.**

(047076-5)



USB BDM debugger for Coldfire

Crossware has developed a USB BDM (background debug mode) debugger for Motorola's ColdFire family of chips.

The USB debugger provides significant advantages over a parallel port BDM interface by ensuring that the data transfer rates from the PC to the debugger are super fast. In addition, advanced synchronisation techniques have been used to optimise the data transfer from the debugger to the target board. Crossware has developed the small yet powerful and fast BDM debugger using the C8051F320 microcontroller from Cygnal (now part of Silicon Laboratories), which features a USB controller and requires no external crystal. The miniature debugger plugs directly into the target board minimising signal delays and ensuring that it will be compatible with the next generation of ColdFire chips running at up to 200 MHz.

The USB debugger is driven by new version of Crossware's source level debugging software, which integrates seamlessly with the rest of its ColdFire Development Suite. The user interface is unchanged and so developers can simply replace their existing parallel port interface with the new USB debugger and immediately benefit from the improved performance. In addition, developers can also move to platforms such as the newer generation of notebook PCs, which do not have a parallel port.

The debugger evolved out of a new version of Crossware's 8051 Development Suite. This version featured Code Creation Wizards to allow the USB controller and other peripherals of the C8051F320 to be rapidly configured. Using this as starting point, and by combining its thorough knowledge of both the C8051F320 microcontroller and

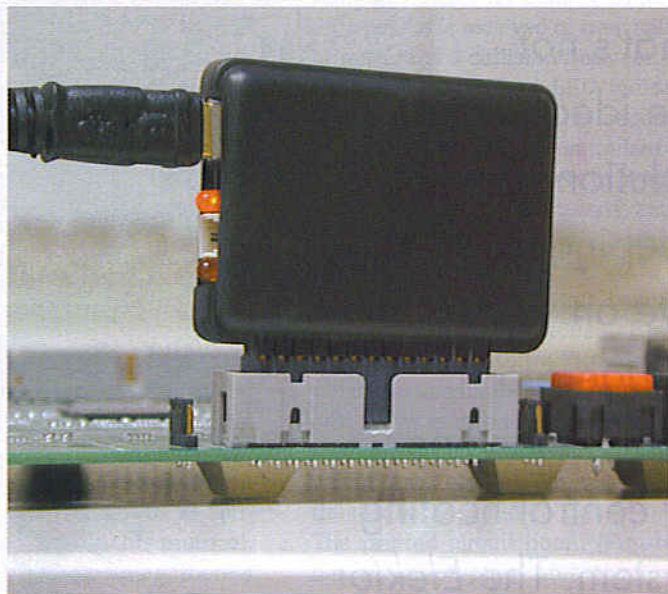

the ColdFire BDM interface, Crossware has been able to leverage the complementary features to create a super fast USB BDM debugger.

(047076-6)

**Crossware, Old Post House,
Silver Street, Lillington,
Royston, Herts, SG8 0QE, UK,
tel: + 44 (0) 1763 853500 or
fax + 44 (0) 1763 853330.
Internet: www.crossware.com**

Micro Web

Jürgen Wickenhäuser

Remote measurement and control is possible via the Internet. Unfortunately, webservers usually sit in large, humming grey cabinets. That's not the ideal solution for keeping an eye on your refrigerator, coffee machine or central heating system. The *Elektor Electronics Micro Webserver* provides an alternative.

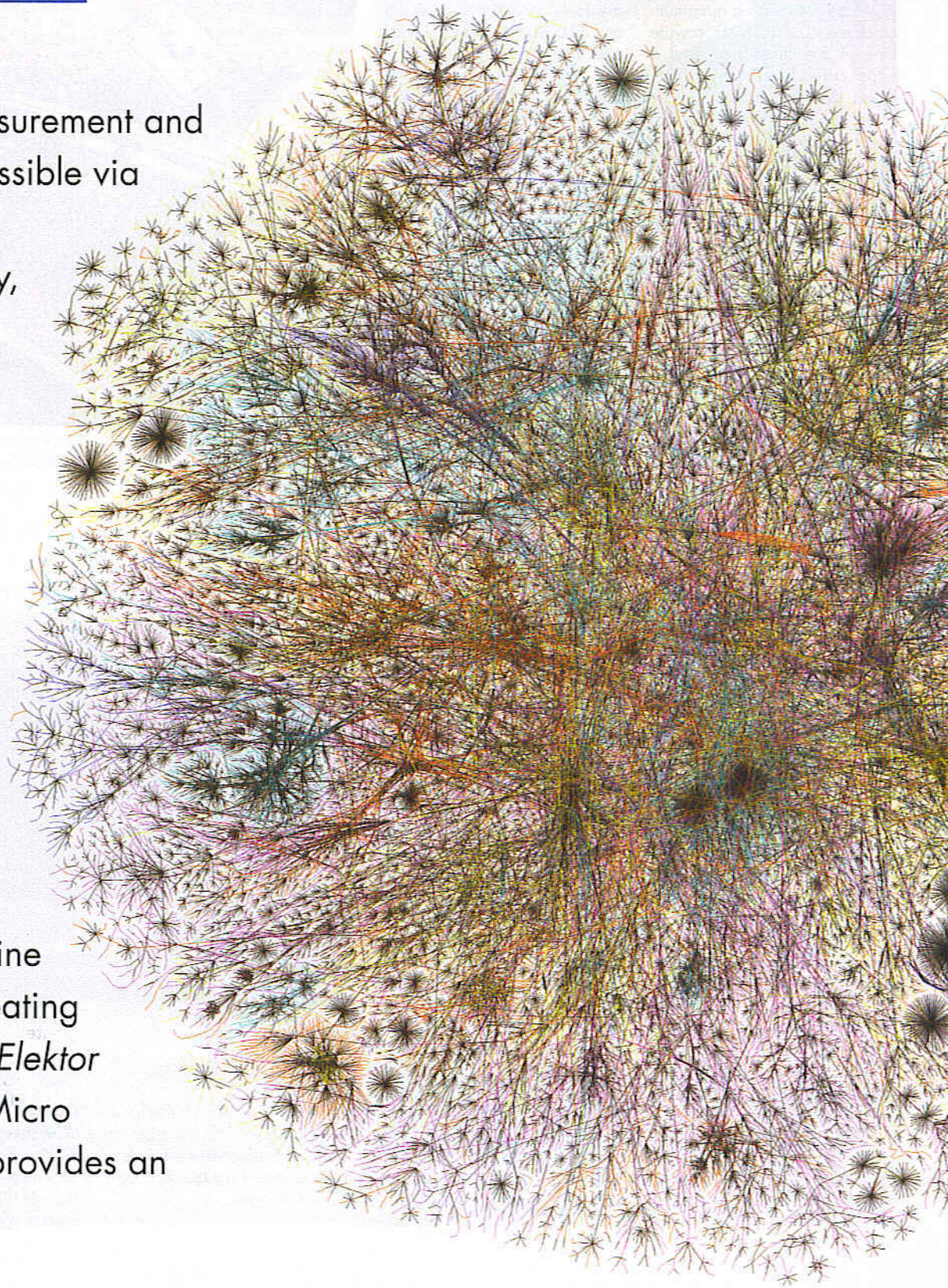

server control and regulation via the Internet



The *Elektor Electronics* Micro Webserver is a full-fledged node for Internet traffic, despite its quite modest dimensions and complexity. It consists of a microcontroller board with a network interface.

Thanks to its compact construction and the versatility of the microcontroller board, the Micro Webserver is an ideal choice for measurement and control applications. Naturally, the fact that it can be read and operated from anywhere in the world via the Internet is a major bonus.

Despite these unprecedented features, the necessary hardware is actually minimal. In principle, two ICs are all you need for a complete webserver. To avoid any misunderstanding, this is not some kind of demo or prototype, but a fully functional device suitable for industrial applications, and its potential uses extend far beyond what we can describe here.

Basic design

The underlying technology is rather complex. Consequently, in this article we must omit a large number of inter-

esting details that are not essential for a 'simple' webserver. However, readers who want to know all the details will find what they're looking for in the accompanying software. The interface is without question unusually user-friendly. For example, the program variables can be used directly in websites. It's hardly possible to make things any easier.

The Micro Webserver is programmed using the C language. But don't let yourself be discouraged if you aren't familiar with C, since this project is certainly suitable for beginners as well.

Connection

Internet and Ethernet are closely related. Ethernet is a standard that defines the connection. The transmission speed is normally 10 or 100 Mbit/s, and it is automatically configured when the connection is established. We use the 10-Mbit/s variant in this project, since it is more than adequate for an embedded webserver.

We assume you already have an Ethernet network. The webserver can thus be connected directly to a hub or switch, so the Internet can be accessed via Ethernet. There are also agreed conventions regarding how Internet communication takes place (via Ethernet, for instance). All of this is specified in the TCP/IP protocol. Here we assume that the network to which the Micro Webserver is connected can also 'speak' this protocol. From a technical perspective, there's no reason why the Micro Webserver cannot also be directly connected to a PC using a crossover cable. However, describing this in more detail is beyond the scope of this article, since in some cases the PC settings must be changed for such a connection.

Hardware

After all these introductory diversions, it's time to get down to brass tacks. The hardware platform is the by now well-proven MSC1210 board (originally described in the 2003 Summer Circuits issue). If you do not already own a copy of this outstanding board, you can obtain one from *Elektor Electronics* together with the extension described here (Figure 1).

The extension is thus new. In principle, it's simply a 'custom' network card for the MSC board. This card is built around the CS8900A Ethernet driver IC (refer to the schematic diagram in Figure 2). As usual with network cards, there are two LEDs (D1 and D2) to indicate the status of the network connection. D1 flashes for 6 ms each time a data packet is received or transmitted, or if there is a collision between two packets. The second LED indicates whether the CS8900A is receiving proper link pulses. These pulses are used in Ethernet networks to synchronise transmitters and receivers, and D2 will be on if this synchronisation is successful.

The network IC also has a complete 10Base-T transceiver. 10Base-T is the standard for 10-Mbit/s Ethernet over twisted-pair cable. The circuit requires only a few external components. The transformer just ahead of the RJ45 connector provides electrical isolation from the rest of the world.

The printed circuit board (Figure 3) has a 'prototyping' area to provide extra space for user applications, in addition to the space on the MSC1210 board. Several spare signal lines are available in the leftmost row of the prototyping area (see Figure 2). Two extra LEDs and a pushbutton switch are also placed on the LAN board. The

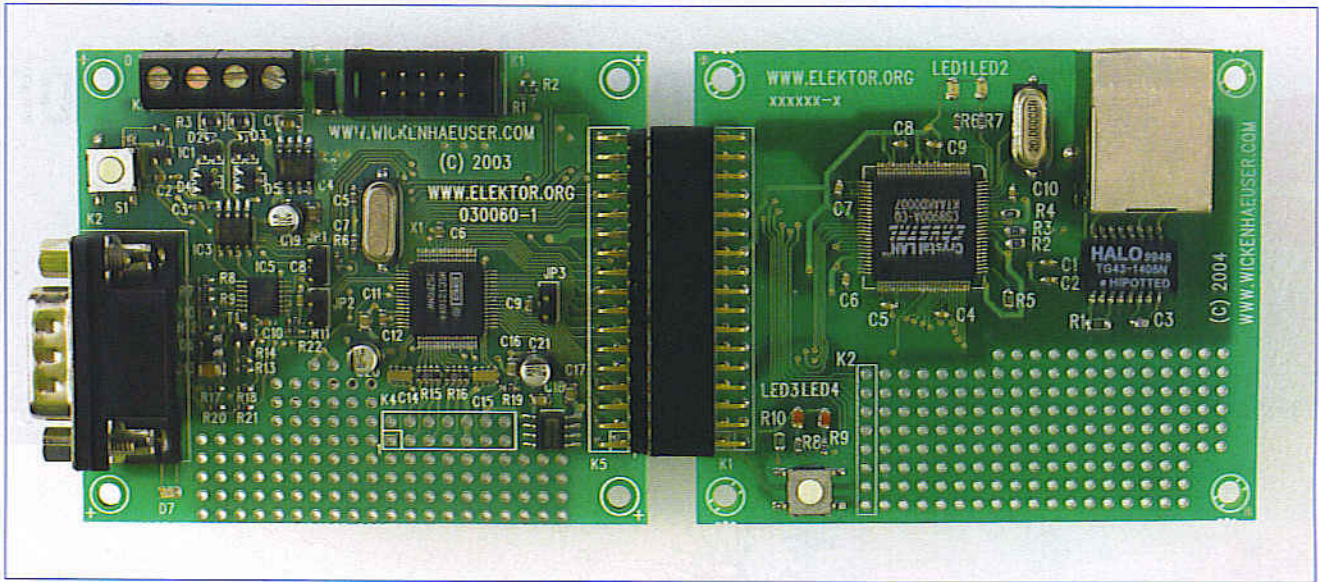

Figure 1. The MSC1210 board with the network extension: a powerful pair!

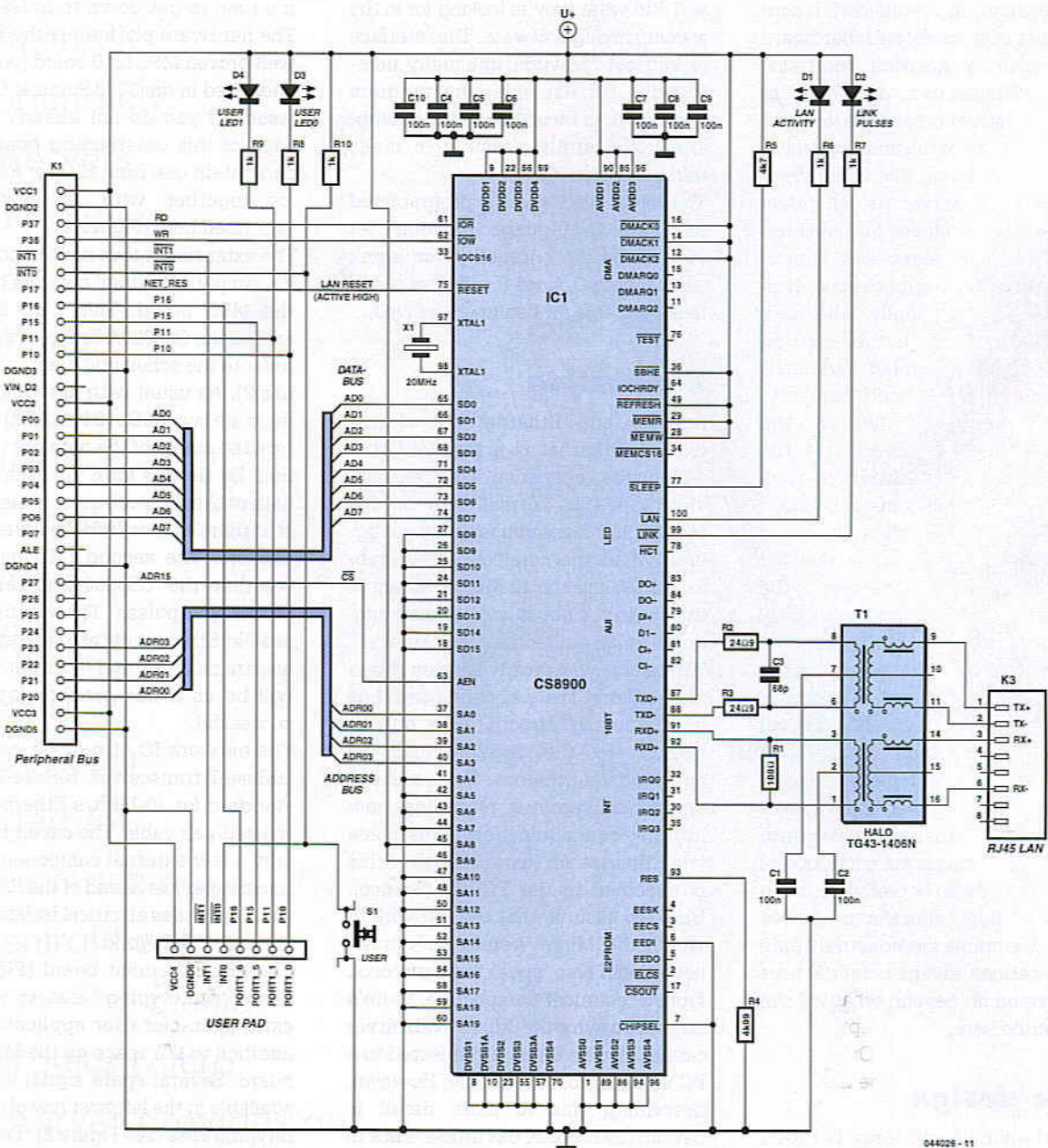

Figure 2. The network card is built around the CS8900 network IC.

Applications

The Micro Webserver is ideal for the following applications:

Automatic online weather station:

- temperature
- precipitation
- lightning detection
- wind strength and direction
- relative humidity
- rain barrel level
- light intensity

Web interface for home appliances and fixtures:

- refrigerator or freezer temperature monitoring
- remote control for coffee machine, central heating or lighting
- controlling sun awnings or roller shutters
- outside lighting
- intruder detection
- greenhouse climate control

Access control and registration in combination with:

- badge readers
- light barriers
- door openers
- RFID tags

Monitoring and controlling machinery:

- rpm
- voltage and current
- temperature
- liquid level
- flow rate / discharge rate
- pressure
- valve control
- relay control or PWM (servo) control

Terminal for a central database (in combination with an LC display and barcode reader)

placement of the connector for the link to the 'motherboard' allows the extension card to be located next to the motherboard or underneath it. In the latter case, the two boards can sandwiched together using standoff bushes.

Although the design of this project is especially simple, there is one thing that must be mentioned. The current consumption of the LAN IC is 100-120 mA, which is relatively high compared with the current drawn by the microcontroller. The 5-V supply voltage is taken from the MSC1210 board. To prevent the voltage regulator on that board from becoming overheated, we strongly recommend that the entire circuit be powered from a voltage of 7.5 to 9 V, but definitely no higher than this.

Online

There's actually not much more to say about the hardware. Configuring the board is fully described in the text box. Once you've gotten the server 'up', you can start testing.

This is where things start to get interesting. To start off, simply connect the board to the network. LED D2 will be continuously on if an Ethernet signal is detected. This is a promising start, but the real test comes next. It consists of trying to 'ping' the server using the Windows Command Prompt window (DOS command window). On a PC connected to the network, type the following command in the command line:

```
ping 192.168.1.156
```

(of course, the IP address here must be the address previously assigned to the

Webserver). LED D1 should start blinking as an indication that data is being transferred via the Ethernet, and a reply from the server should appear in the command window.

Ping is a simple protocol that allows a few bytes to be transmitted and waits for an 'echo'. It's a really handy way to quickly check a network connection.

If the ping test is OK, you can then access the webserver using a web browser. In the browser window, enter the following address:

```
http://192.168.1.156
```

(use the address that has previously been assigned to the webserver). And that's it: what you see next comes from that little board (see **Figure 5**).

In the terminal download window, you can also see which page was requested.

How it works

What actually happened when you requested the web page? First, you made a connection to an IP address. Actually, it's a bit more complicated than that: you made a connection to a 'socket' at a particular address. A socket is a sort of 'connector', in this case one that only fits web links. Each socket is also assigned a specific port

number. Port 80 is frequently used for web servers. You can see this in the program line `SOCKET_SETUP(i, SOCKET_TCP, 80, FLAG_PASSIVE_OPEN)`.

The final parameter here indicates that the socket is passive, which means it waits for requests from clients. The sockets are created in a FOR loop. The number of sockets created determines how many clients can be connected to the server at the same time. As each socket costs memory, the total number is limited. The CS8900A IC used here also has a buffer (approximately

4 kB) for incoming Ethernet packets. That's not especially large if several users want to connect to the server at the same time, or if large items such as images are requested. Actually, this doesn't matter all that much, since TCP allows the occasional packet to remain unanswered. If necessary, the client resends unanswered packets on its own initiative.

After the sockets have been created, `ELM_FLEX.C` initiates the A/D converter of the microcontroller a few lines later in the code. For more information about the A/D converter, see the companion Micro Webserver article 'Measurement and Control via the Internet' in this issue.

After this, the program enters an endless FOR loop. In this loop, `poll_web`

Internet references

- [1] www.wickenhoeuser.com
µC/51 compiler with source code
- [2] www.mikrocontroller.info/kabelsalat/
Wiring diagram for a null-modem cable
- [3] www.ti.com/msc - MSC121x home page
- [4] groups.yahoo.com/group/TI-MSC
MSC121x users group. Definitely worth the effort. Free, but registration is required.
- [5] groups.yahoo.com/group/TI-MSC/files
You can find tools for the MSC121x here, such as the original TI downloader.
- [6] www.cirrus.com/en/pubs/proDatasheet/cs8900a-4.pdf
Data sheet for the CS8900A network driver

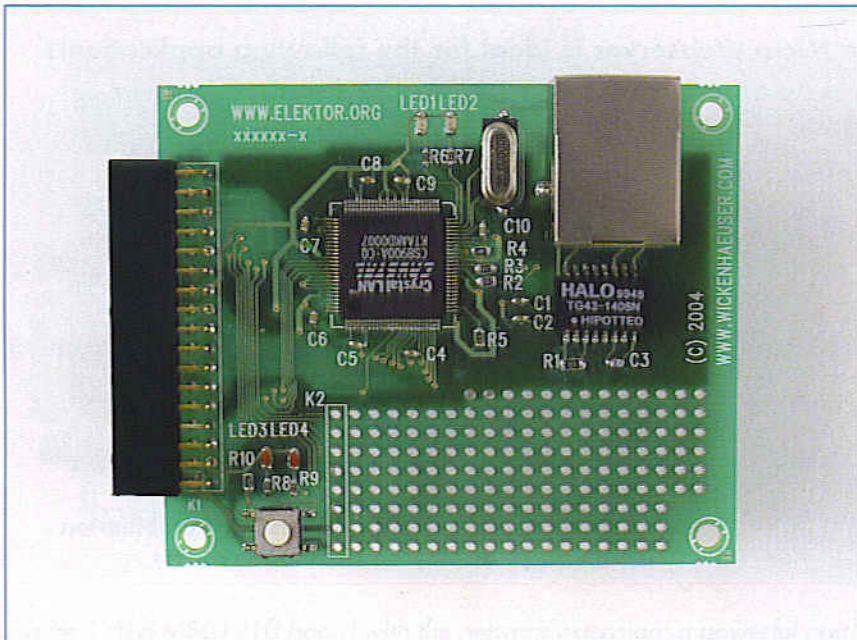

COMPONENTS LIST

Resistors (SMD):

R1 = 100Ω, shape 0603
 R2,R3 = 24Ω, shape 0603
 R4 = 4kΩ99, 1 %, shape 0603
 R5,R10 = 4kΩ7, shape 0603
 R6-R9 = 1kΩ, shape 0603

Capacitors (SMD):

C1,C2,C4-C10 = 100nF, shape 0603, ceramic
 C3 = 68pF, shape 0603, ceramic, NPO

Semiconductors (SMD):

IC1 = CS8900A-CQ (5 V), shape TQFP100
 D1-D4 = chip-LED, shape 0805
 Recommended colours: D1 green; D2 yellow; D3,D4 red

Miscellaneous:

T1 = Ethernet transformer type TG43 (Halo) or ST7010T (Valor), see also ref. [6]
 X1 = 20MHz quartz crystal, HC49_SMD case
 K1 = 34-way DIL pinheader
 K2 = 8-way pinheader
 K3 = RJ45 connector (screened)
 S1 = mini pushbutton

For software, bare PCBs and fully assembled boards, see the 'What you need' box.

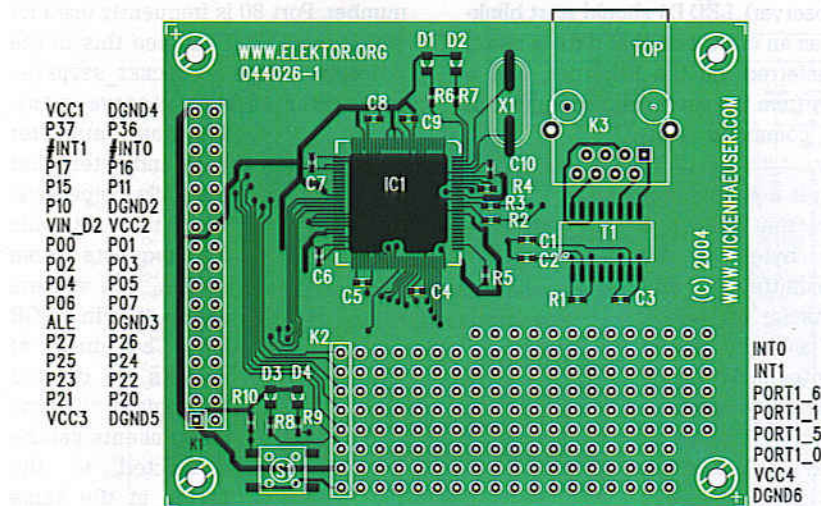

Figure 3. The network card for the MSC1210 board.

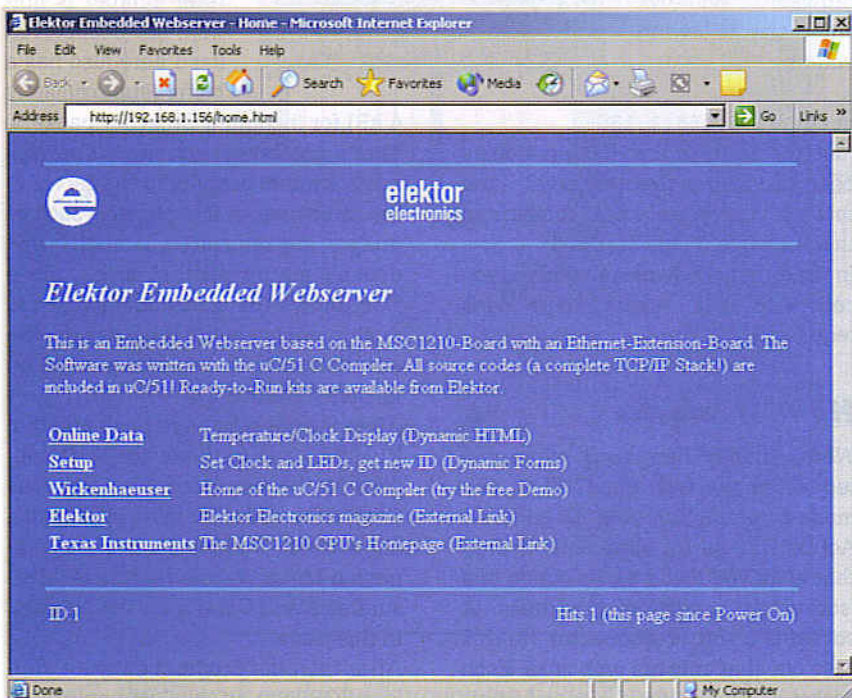

Figure 4. The web page sent by the micro webserver.

Configuring the board

The Micro Webserver only works in a TCP/IP network. Just like all other computers in a TCP/IP network, the microcontroller is assigned a unique address, which is its IP address. Before you start programming the microcontroller, you must manually specify this address, since the Micro Webserver does not work with automatic address assignment. The default IP address is set to 192.168.1.156. It belongs to a range of addresses that are specifically reserved for networks that are not directly connected to the Internet. Subscribers to ADSL or cable Internet use addresses in this range for their local networks. Addresses having the form 10.0.0.x also belong to this category. It may also be possible to request a 'real' Internet address for your Micro Webserver, but that depends on your provider. In any case, you must personally check which address range is used in your network and which addresses are available to be assigned to the server.

After choosing an address, you can turn your attention to the necessary programming software and C files. Part of the required source code (the part that implements the actual webserver) is included with the uC/51-compiler (from version 1.20 onwards). A fully functional demo version of this compiler can be downloaded free of charge from the author's home page (see reference [1]). The only difference between the demo version and the registered version is that code size for the Micro Webserver is limited to 16 kB, but that's more than enough for this application. Sample source code for initialising the webserver and implementing web pages (including several sample pages) is included in the package.

After installing the uC compiler, you must first use MakeWiz to create a workspace. In MakeWiz, open the file ...SRC\MSC1210\ELM_FLEX\ELM_FLEX.MAK. Then change something in the text (for example, add your own version number) so that the Save button will be enabled. Tick the 'Write JFE-Workspace File' check box and save the file (Figure 5).

Now you can start the JFE editor (with thanks to Jens Altmann). In JFE, use 'Open Workspace' to open the file ...SRC\MSC1210\ELM_FLEX\ELM_FLEX.WSP. All of the files belonging to the project will appear in the editor window. Now you have to specify the previously determined IP address in the ELM_FLEX.C file. You can do so in the line `COMPOSE_IP(my_ip, 192.168.1.156)`.

A workspace that has been created using MakeWiz causes three special buttons to appear in JFE: 'MAKE', 'RE-MAKE' and 'DL.BAT'. The MAKE button causes the project to be compiled, but it limits processing to the files that have actually been modified. This is the usual (and fastest) way to generate the hex file you need for programming the microcontroller. RE-MAKE must be used if something not present in the workspace has been modified, such as a header file (.h). This command causes everything to be recompiled. Finally, DL.BAT causes the result to be sent to the MSC board. This actually amounts to simply executing a batch file, to which JFE passes a parameter. This parameter is always the name of the target file, which in this case is ELM_FLEX (with no extension).

The specific command line that initiates downloading to the MSC board is stated in the batch file (which is also located in the project folder). In this case, the command line is `download /F%1.hex /X11 /P1 /T /B9600`.

Parameter P1 indicates that COM1 of the PC must be used for programming. This can be changed if necessary.

So far, so good: you've modified the IP address in ELM_FLEX.C, you've compiled the project, and your finger is just itching to press DL.BAT — but hang on a

moment! Before you can download anything to the board, you have to acquire a copy of the original Texas Instruments downloader (Downloader.exe). You can obtain this from the MSC group site at Yahoo (reference [4]), among other places, and it can be placed in the project folder. If you wish, you can also place it in a more general location, but in that case you naturally have to specify its new location in DL.BAT.

Be sure to fit jumpers J1 and J2 on the MSC1210 board (J3 must remain open). If J1 and J2 are not fitted, the board is protected against resetting and modifying the firmware via the PC. Finally, you need a null modem cable to connect the board to the PC, but that should be obvious. After you've found a place for the downloader, modified DL.BAT if necessary (to specify a different COM port or change the path to the downloader), connected the board to the proper PC port, and powered up the board, you're finally ready to click on DL.BAT in JFE.

If everything goes as it should, the MSC1210 board will return a short greeting message, and if '<NET FAILURE>' is not included in this message, the Ethernet board has been successfully recognised. In addition, one of the red LEDs on the MSC board should blink slowly.

After downloading the code, don't forget to remove jumpers J1 and J2.

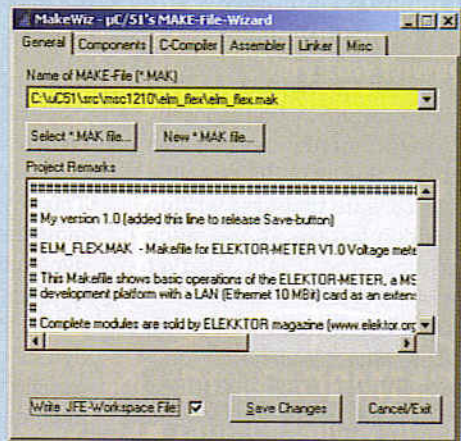

Figure 5. Use MakeWiz to store the project.

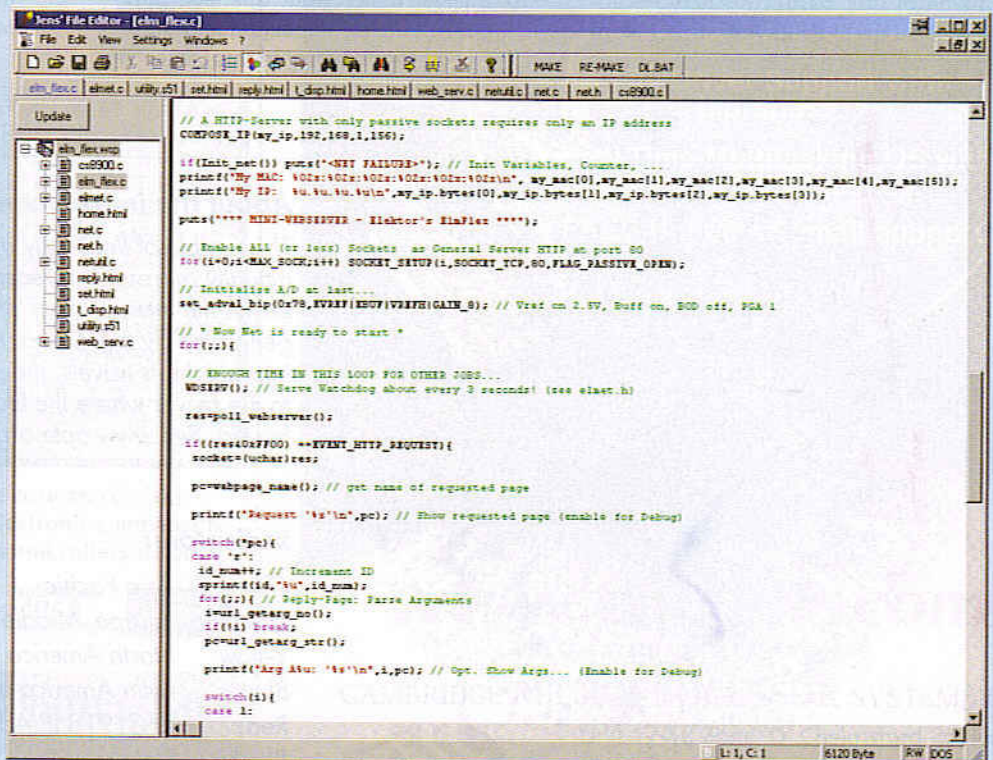

Figure 6. With JFE, all files are easily accessible.

What you need

The Micro Webserver consists of:

- the MSC1210 'Precision Measurement Central' board (see the July/August 2003 issue of Elektor Electronics)
- the 10-Mbit Ethernet network card (RJ45, twisted pair)
- the μ C compiler with the necessary software (Readers Services order code 044026-11)
- the TI downloader program (Downloader.exe)

The MSC1210 microcontroller card and the associated network extension are available from Elektor Electronics. The μ C compiler, including all the necessary source code, can be downloaded at no charge from www.wickenhaeuser.com or from the Elektor Electronics website.

The programming software for the MSC board (Downloader.exe) is available from reference [4]. Updates will be available from the author's website.

Prices:

- ready-made MSC1210 board: £69.00 (US\$112.50) (assembled and tested; Readers Services order code 030060-91)
- ready-made network extension for the MSC1210 board: £41.95 (US\$73.95) (assembled and tested; Readers Services order code 044026-91)
- combined package: assembled MSC1210 board, network extension and all related Elektor Electronics articles on diskette: only £103.50 (US\$184.95) (Readers Services order code 044026-92)

For die-hard DIYers, bare PCBs are also available for the MSC1210 board (Readers Services order code 030060-11) and the network extension (Readers Services order code 044026-11). Note that most of the components are SMD types, and some of them are very difficult to obtain as one-offs as well as solder by hand.

server() is called periodically. As long as the result returned by this call is '0', other (user-written) routines can also be executed in this loop. However, it's important to ensure that user-written extensions do not take up too much processor time, since the webserver will otherwise become inaccessible. The FlexGate TCP/IP stack works with events. The Micro Webserver only responds to `EVENT_HTTP_REQUEST` (page request) and `EVENT_SOCKET_IDLETIMER` (which has a period of approximately 0.5 s). If a client wants to access a page, the name is first requested using `web_page_name()`. Following this, `web_page_bind()` is used to prepare the cor-

responding page for the reply. Pages that are to be externally available must be declared in advance as array extern code uchar (see `ELM_FLEX.C`). This completes the process if the requested page does not contain any dynamic data. However, dynamic data is exactly where the power of this handy little device lies. An example of dynamic data is measurement data coming from the microcontroller board. Such data can easily be incorporated into a web page. And in the other direction, you can remotely control the microcontroller outputs via a web page. To find out more about this, see the companion article 'Measurement and Control via the Internet' in this issue.

Naturally, there's a lot more we could say about the Internet portion of the software (the TCI/IP stack), but that goes beyond what we had in mind for this article. If you want explore this question in more detail, have a look at the manual for the stack. You'll find it in the folder `...SRC\FLEXGATE\` that comes with the microcontroller compiler. In addition, Texas Instruments is presently preparing an application note for this project. The details will appear in due time on the TI website.

(044026-1)

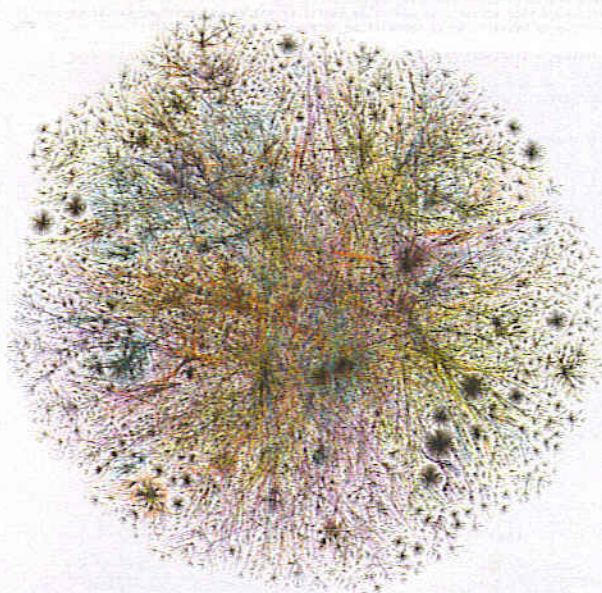

About the introductory illustration:

This jumble of lines may appear chaotic, but it actually represents a reasonably well-organised entity: the Internet. This 'map' was automatically generated by a program that literally combs the Internet. In its travels, the program also came close to the server where the Elektor Electronics website is hosted. See www.opte.org.

Indicators:

- Cyan: Asia Pacific
- Pink: Europe, Middle East, Central Asia, Afrika
- Yellow: North America
- Blue: Latin America and Caribbean
- Red: RFC1918 IP Addresses
- Black: Unknown

Handyscope HS3 2 ch

Resolution Menu - 12, 14 or 16bits

Sample Rates - 5,10,25,50,100 Ms/s models



- ✓ Oscilloscope
- ✓ Spectrum Analyzer
- ✓ Voltmeter plus!
- ✓ Transient Recorder
- ✓ Arbitrary Waveform Gen.
- ✓ Two hi-z probes 1:1~1:10
- ✓ USB 1.1 or 2.0
- ✓ Windows OS- all

5 Ms/s Model
£435
 ex VAT/pp

iTp Ltd

28 Stephenson Road, Industrial Estate, St Ives, Cambs. Pe27 3WJ
 Telephone: 01480 300695 Fax: 01480 461654

info@itp101.com www.itp101.com www.tiepie.com

FRUSTRATED!

Looking for ICs TRANSISTORS?
 A phone call to us could get a result. We offer an extensive range and with a world-wide database at our fingertips, we are able to source even more. We specialise in devices with the following prefix (to name but a few).



2N 2SA 2SB 2SC 2SD 2P 2SJ 2SK 3N 3SK 4N 6N 17 40 AD
 ADC AN AM AY BA BC BD BDT BDV BDW BDX BF
 BFR BFS BFT BFX BFY BLY BLX BS BR BRX BRY BS
 BSS BSV BSW BSX BT BTA BTB BRW BU BUK BUM BUV
 BUW BUX BUY BUZ CA CD CX CXA DAC DG DM DS
 DTA DTC GL GM HA HCF HD HEF ICL ICM IRF J KA
 KIA L LA LB LC LD LF LM M M5M MA MAB MAX MB
 MC MDAJ MJE MJF MM MN MPS MP5A MP5H MP5U
 MRF NJM NE OM OP PA PAL PIC PN RC S SAA SAB
 SAD SAJ SAS SDA SG SI SL SN SO STA STK STR STRD
 STRM STRS SVI T TA TAA TAG TBA TC TCA TDA TDB
 TEA TIC TIP TIPL TEA TL TLC TMP TMS TPU U UA
 UAA UC UDN ULN UM UPA UPC UPD VN X XR Z ZN
 ZTS + many others

We can also offer equivalents (at customers' risk)
 We also stock a full range of other electronic components
 Mail, phone, Fax Credit Card orders and callers welcome

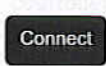

Cricklewood Electronics Ltd

40-42 Cricklewood Broadway London NW2 3ET
 Tel: 020 8452 0161 Fax: 020 8208 1441

A QUANTUM LEAP IN EMBEDDED CONTROLLERS

Quick FIRE

SUPERCONTROLLERS

Our range provides:-

- The fastest 68000 based Core up to 66 Mhz.
- Extensive I/O:- Serial, IrDA, SPI, I²C, Analogue, Timers/Counters, RTC, etc.
- Large Memory Capacity:- Flash, SRAM, DRAM.
- Supports:- Mono & Colour LCD's, Touch Panels & Keypads, Very Low Power.

ALSO LOW COST

DEVELOPMENT

- Target easily & quickly.
- Full ANSI 'C' compiler, assembler & linker all Windows32 based.
- Source Level Debug.
- Full Driver Support with Libraries.
- Real Time Multitasking OS with a free run time licence.
- FREE Unlimited email support.

www.cms.uk.com

see our web site for full details

CAMBRIDGE MICROPROCESSOR SYSTEMS LTD



Unit 17-18 Zone 'D' Chelmsford Rd. Ind. Est.
 Great Dunmow, Essex CM6 1XG
 Telephone: **01371 875644**
 email: sales@cms.uk.com

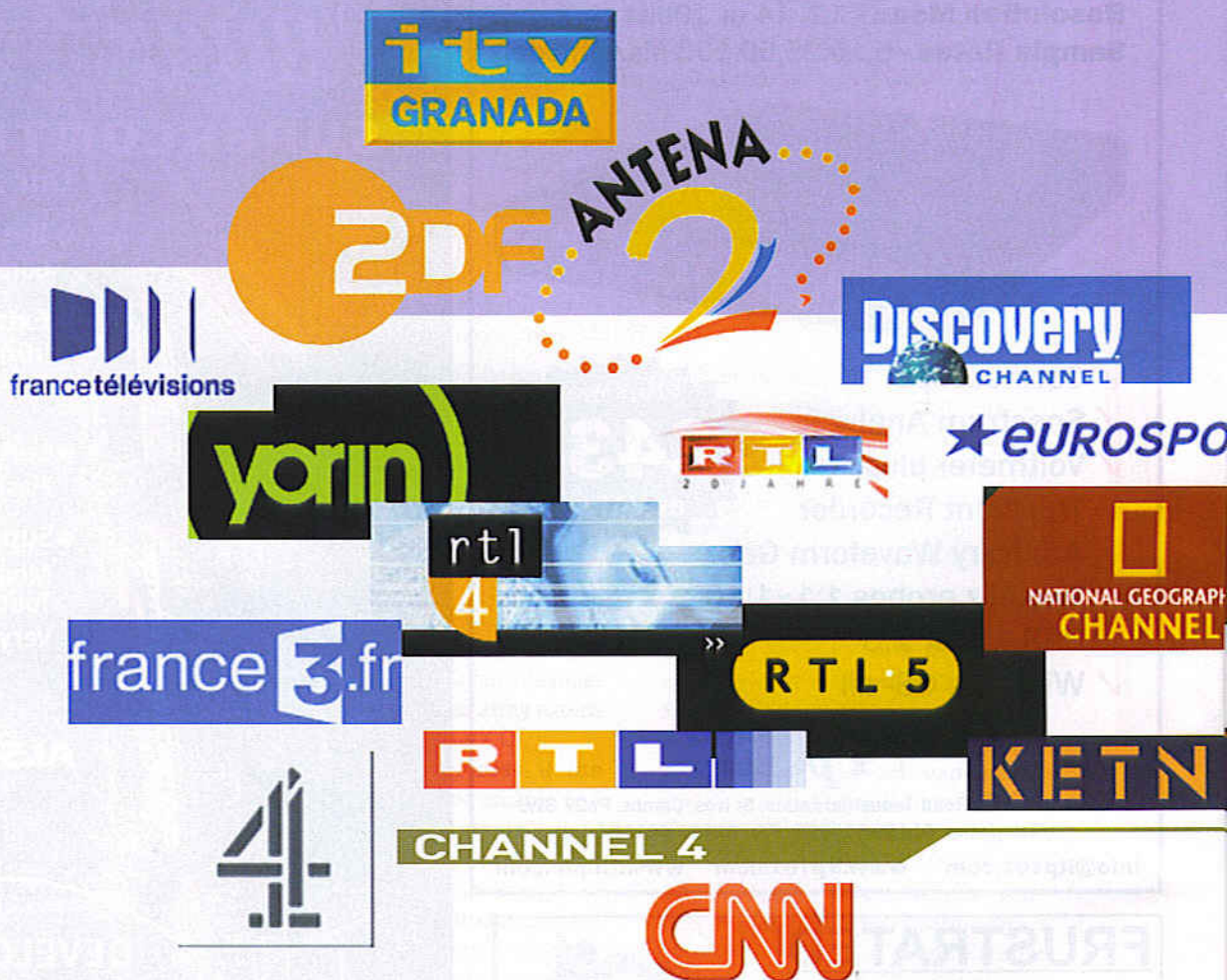

Michael Schulze

TV Commercials Killer

Pause recording during ad breaks

Stop those annoying advertisement breaks spoiling your recordings with this ingenious circuit. Its basic ingredients are an overclocked Scenix SX28 microcontroller running some clever software, fast static RAM and a two-way 'code-learning' infrared remote control that obviates surgery to the family's precious VCR. Curious about the operation? Read on...

Anyone who has ever recorded a programme from a commercial broadcaster onto video or DVD will know the problem: either you have to stand over the recorder and press the 'STOP' button when the advertisements start (and then forget to press 'RECORD' when the programme continues), or you have to subsequently go through and edit out the breaks; or, of course, you can just put up with them. Alternatively, you can in some cases pay for services that are free of advertising.

How it's done

This advert killer, dubbed 'ViConti' (for 'Video Continue', which, along with 'ViConti', is a registered trademark) uses the fact that, in general, a broadcaster's logo appears in the corner of the screen during normal programming, including feature films and the like, but that the logo disappears during advertisements (or commercial breaks as our US friends call them). The circuit must therefore:

- Determine whether the broadcaster's logo is present on the screen, and, if so, where;
- Monitor the picture to check when the logo disappears;
- send an infra-red command to the recording equipment (VCR or DVD) to pause recording;
- continue to monitor the picture and restart recording when the logo appears again.

Real-time image processing is relatively straightforward these days. PCs and special-purpose signal processors are up to the task, but these tend to be rather expensive. Run-of-the-mill microcontrollers are much too slow,

and at this point this article would come to an abrupt end were it not for the Scenix (now known as Uvicom) SX28 microcontroller. Because of its incredibly high speed, this device provides a cheap alternative to signal processors in some applications. The SX28 was originally specified to run at 50 MHz. Experiments have shown, however, that it can run without problems at at least 80 MHz. Meanwhile, 75 MHz devices are now standard, and a 100 MHz version was announced some time ago, although it is not yet available.

Now we have looked at the microcontroller, it is time for a quick look at the circuit diagram in **Figure 1**. The other important components are the familiar LM1881 video sync separator (IC9) and an ADC1175 analogue-to-digital converter. Also connected to the microcontroller are a 64k-by-4 static RAM type IDT61298 (IC5), for storing picture information, and an I²C EEPROM. The RAM is controlled serially from the microcontroller using two fast counters (IC3 counting the pixels within a line, IC8 counting the lines of the picture). The ICS502 clock multiplier generates an 80 MHz clock for the microcontroller from the 20 MHz crystal. The A/D converter is clocked at 20 MHz. The amplifier built around T1 and T2 raises the level of the video signal to be processed to about 2 V and the colour carrier is filtered out by L1, C5 and C6. The amplified signal is digitised to 8 bits by A/D converter IC2 and presented to port RC of the microcontroller.

The video sync separator extracts a line clock (BP) from the video signal, which is used to synchronise the microcontroller and drive the clamp circuit (IC7c and T3) in such a way as to ensure that the AC-coupled video sig-

nal has the correct DC offset applied. Also, the odd/even (O/E) signal is monitored by the software to enable the two video fields to be correctly assembled in the memory. The infra-red signal that the microcontroller must use to stop the recorder during an advertisement break must first be learned from the recorder's remote control. This facility is provided by the circuit using a type SFH203A infra-red receiver. Originally the output of the receiver fed directly into a Schmitt trigger input, but here an ordinary NAND gate (IC7d) does the same job. The sensitivity of the receiver is deliberately low (the range is just a few centimetres), and so no amplification of the signal is required. After the Schmitt trigger circuit the signal needs to be taken to microcontroller input RB1 via the multiplexer constructed from IC7 and T4.

The two infra-red signals received from the remote control (for 'RECORD' and for 'PAUSE') are stored in serial EEPROM IC6, a 24C08. When needed, the signals are read from the EEPROM and sent out using infra-red transmitter diode LD1 (an LD271H).

The ViConti ad killer has no display. Instead, it shows its status using light-emitting diodes D3 and D4. These are driven using a single control signal, but nevertheless are capable of four different indications: both off, green on, red on, or both on.

Three steps

How does a human being recognise the broadcaster's logo? The characters and the style help, as does familiarity from, for example, television listings magazines. Unfortunately, our microcontroller doesn't read listings magazines, and doesn't have a *déjà vu* input. How, then, can we get the microcontroller to recognise the broad-

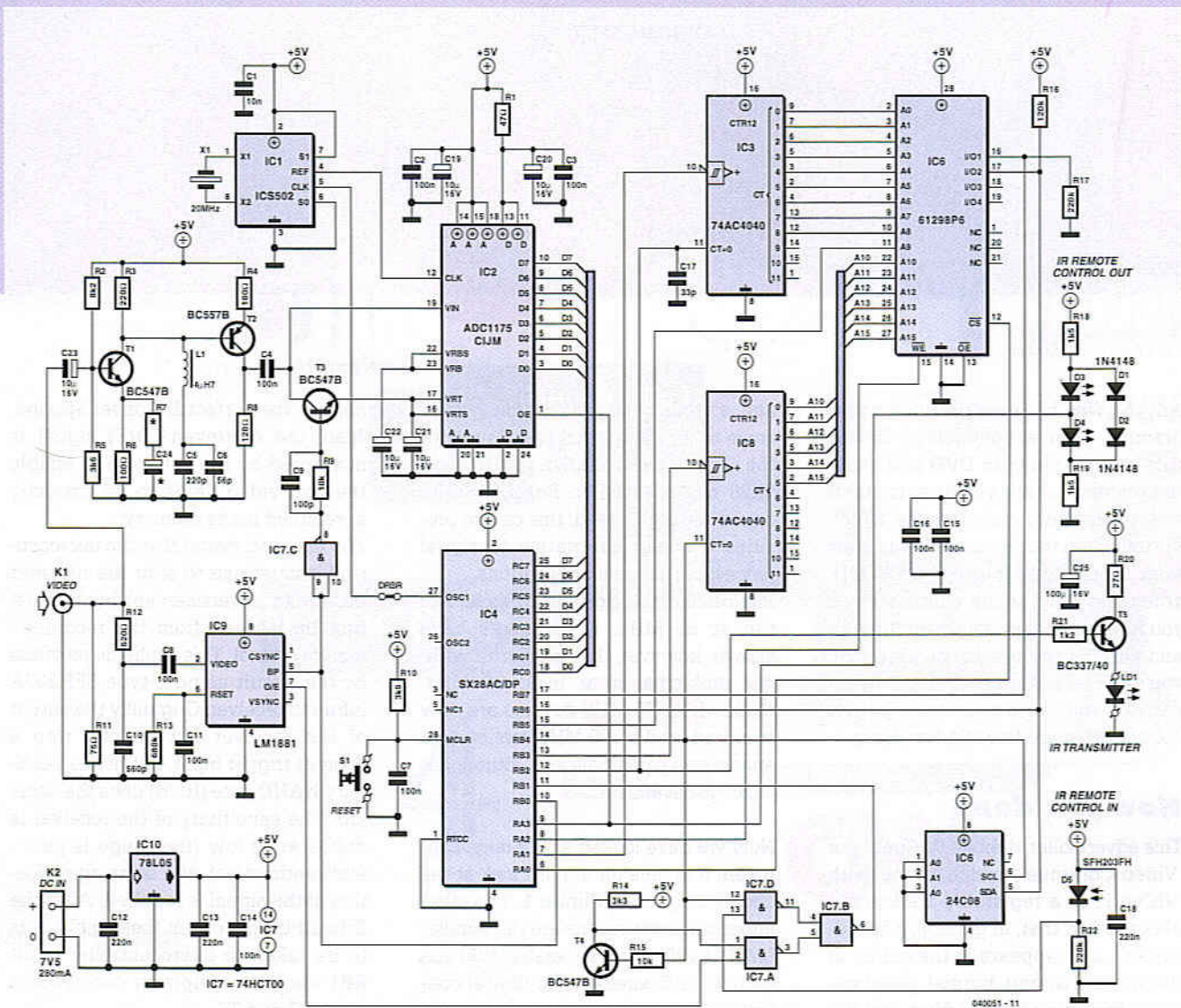

Figure 1. The ViConti advertisement killer uses an overclocked Scenix microcontroller.

caster's logo?

In general, the broadcaster's logo is the only static content in the picture, while the rest of the picture changes more or less quickly. Hence we simply need to check which area of the picture does not change other than at the moment when the logo is switched off for the advertisement break.

The logo must be recognisable on black-and-white televisions, and so it is sufficient to process a monochrome picture. In the area where the logo sits the pixels of the image always have the same brightness. In the digitised picture the samples always have the same value, whereas nearby samples will to some extent exhibit variations in brightness.

Phase 1

If we suppose that the broadcaster's logo has a minimum brightness of say 20 %, then we might expect that nearby pixels will sooner or later (and hopefully before the first advertisement break) fall below this threshold, depending on the nature of the programme. We can then deduce that they do not belong to the logo. This is enough to recognise the logo and to build up a black-and-white map of the image in the first bit of the picture memory. Black is represented by 0, white (i.e., logo) by 1. Figure 2 shows part of an original picture along with the filtered logo.

The microcontroller loads the 8-bit pixel value from port RC, compares it

with a threshold value, and, if it is recognised as not belonging to the logo, writes a black pixel into the corresponding position in the picture memory (in the first bit). The pixels in the memory are initialised to white. Because there are only 136 bytes of internal RAM available in the SX28, an external memory is required. In order to help economise on port pins, two fast counters are added to drive the address lines of the memory.

The assembler program in the SX28 microcontroller, running at 80 MHz, takes precisely nine machine cycles (i.e., nine instructions) at 12.5 ns each to process each pixel (see **program snippet 1**).

From this we can calculate that in the visible part of each television scan line, which lasts approximately $52 \mu\text{s}$, we have a total of about 460 pixel samples. The line-by-line synchronisation of the program with the incoming scan lines is achieved using an external interrupt obtained from the line signal from the LM1881.

Only a stripe of 128 lines from the upper third of the picture is sampled, since this is where the broadcaster's logo is generally located. At regular intervals a test is made to determine whether the white pixels (i.e., those considered as belonging to the logo) all fall within a reasonably-sized rectangle in either the upper right-hand or upper left-hand corner of the screen. If this is the case, the second phase begins.

Phase 2

Since it is desirable to be able to react to the absence of the logo very quickly, ideally within a fraction of a second, we need criteria to determine whether or not the logo is displayed which are independent of changes in the picture content. Here again the black-and-white image must suffice. The logo stored in the picture memory consists of a few hundred pixels and has a characteristic average brightness value, which is usually rather different from the average value of the surrounding pixels. Typical values for the average brightness in the logo and for that in the surrounding pixels are determined in this phase before monitoring begins. The size of the logo is determined by a line-by-line search through the picture memory looking for the outermost white pixels. A border three pixels wide is added, and this gives the coordinates defining the 'logo rectangle', i.e. the area of the picture that is monitored for the presence of the logo. The number of white pixels that make up the logo is now counted, and exactly

PROGRAMM SNIPPET 1

```

mov W,#$02           ;Pixel counter: 460 Pixel per line!
mov $1E,W
mov W,#$CD
mov $1D,W           ;Loop to check a picture line

:loop1 setb RA.0     ;Reset ext. memory write pulse?
      clrb RA.1     ;Reset ext. pixel counter clock?
      mov W,#$33    ;Threshold for logo search
      mov W,RC-W    ;When W < RC then Carry Flag set
      rl RA         ;Ext. memory write pulse
                        ;when Carry not set
                        ;Ext. pixel counter clock

      decsz $1D
      jmp :loop1
      decsz $1E
      jmp :loop1

```



Figure 2. Above, a section of the original picture in black and white; below, the filtered logo.

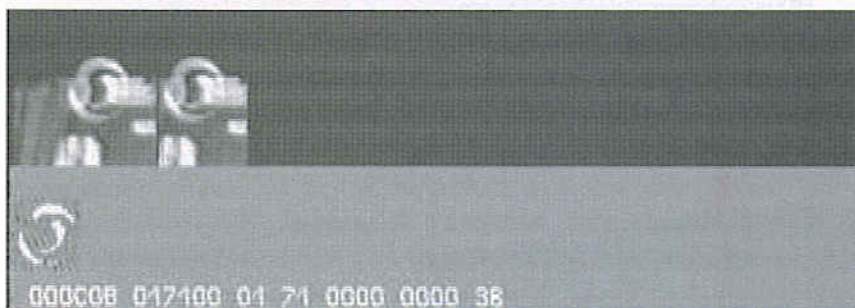

Figure 3. Section of the original picture shown next to the stored version, which is compared with the logo below. Below, the white pixels represent the logo, the black pixels the reference pixels, and the grey pixels are neutral. The numbers show the threshold and reference values.

the same number of black pixels is added at random into the logo rectangle. The remaining pixels are set to neutral ('grey') by setting the second bit in the picture memory.

Phase 3

In phase 3 the picture is monitored in real time, that is, frame by frame. In

each frame the average brightness of the logo pixels is calculated, as is the average of the same number of pixels not belonging to the logo, spread out over a representative area. If the difference between these two values falls below a preset threshold several times, this indicates that the logo has disappeared.

PROGRAM SNIPPET 2

```
mov W,$1D          ;Contains width of logo rectangle
mov $04,W

:loop4 setb $04.4
nop
mov W,RC           ;xxx Byte, read image from ADC into RAM
mov $00,W
nop
incsz $04
jmp :loop4
```

PROGRAM SNIPPET 3

```
mov W,$1D
mov $04,W

:loop5 inc RA      ;xxx Byte, read from RAM and add
setb $04.4
mov W,$00
snb RB.6          ;Memory bit, ext. image memory
jmp :grey
sb RB.7           ;Memory bit, ext. image memory
jmp :blk
add $09,W         ;Add white
snb C_Flag
incsz $0A        ;Sum white in $0B, $0A, $09
dec $0B
inc $0B
dec RA
incsz $04
jmp :loop5
ret

:blk add $0C,W    ;Add black
snb C_Flag
incsz $0D        ;Sum black in $0E, $0D, $0C
dec $0E
inc $0E
dec RA
incsz $04
jmp :loop5
ret

:grey jmp :x3     ;Dummy for grey pixels
:x3 jmp :x4
:x4 dec RA
incsz $04
jmp :loop5
ret
```

Figure 3 shows a segment from an original image, and, next to it, the stored version which is compared to the logo below. Here the logo pixels are shown as white, reference pixels as black, and neutral pixels as grey. The numbers show the threshold and refer-

ence values.

The bit samples from the infra-red remote control stored in the EEPROM which represent the command to stop recording are sent to the infra-red transmitter. With luck they are then detected by the recorder, which will

stop recording.

The programme continues to be monitored. The average brightness difference threshold for detecting the return of the broadcaster's logo is now set somewhat higher. As soon as the logo is clearly detected, the infra-red transmitter sends out the command to continue recording.

In the monitoring phase the position of the logo in the television picture is known. Line by line, just the sequence of pixels belonging to the logo is selectively stored in the internal RAM of the microcontroller. This is carried out at exactly the same resolution as in phase 1, in precisely nine machine cycles per pixel (see **program snippet 2**).

In the remaining time until the end of the scan line the stored pixels are processed according to whether they are logo pixels (white), reference pixels (grey) or neutral pixels (grey). The various brightness sums are calculated (see **program snippet 3**).

When all the pixel brightnesses have been added together, the difference between the sums for logo pixels and reference pixels is calculated, and compared with a suitable threshold value which depends on the size of the logo. When frames which exhibit too small a difference are encountered several times in a row, the logo is judged to be absent and the infra-red command to stop the video recording is transmitted.

A software module to drive the I²C bus as a so-called 'virtual peripheral' is available from Scenix and has been modified here to drive the EEPROM to store the infra-red remote control command codes for the recording device to be controlled.

Since there are only two different infra-red commands to send to the recorder, we can offer a learning function. In

Note:

For correct operation of the TV ad killer the following are essential:

- The broadcaster's logo must appear in the upper third of the screen, in a fixed position (as is generally the case).
- A good video signal is required. If the picture is not perfectly in sync, the logo can jitter (even though this may not be evident to the eye). The logo may then not be correctly recognised.

learning mode, incoming pulses are sampled using an interrupt and quantised to a timebase. The count values are stored permanently in the EEPROM. In use, the values are fetched from the EEPROM and stored in RAM, so that the sequence of pulses for the code used can be reconstructed with good accuracy and sent out using the infra-red transmitter.

In use

A prerequisite for satisfactory operation is a very good video signal. If synchronisation is not perfect, the logo can jitter (even though this may not be evident to the eye). The logo may then not be correctly recognised.

When power is applied, or after the reset switch is pressed, the program runs in four stages. In the first stage the two infra-red command codes for controlling the recorder can be set.

LEARN IR CODES

turn on green LED
wait for IR signal

You now have approximately four seconds in which to press the required button (for example, 'REC') on the remote control. The infra-red transmitter on the remote control should be just a few centimetres from the receiver diode on the advertisement killer. If no infra-red signal is received within four seconds, the program jumps to 'FIND LOGO'; otherwise, it proceeds as follows:

IR signal recognised
green LED blinks
read IR signal
store code in EEPROM
turn off green LED
turn on red LED
wait for IR signal

The procedure for learning the 'PAUSE'

code is the same, except that only 2 s is allowed. If no infra-red signal is received within 2 s, the program jumps to FIND LOGO. Otherwise it proceeds as follows:

IR signal recognised
red LED blinks
read IR signal
store code in EEPROM
turn off red LED

The record and pause commands (you can of course use any other remote control commands you choose) need only be programmed in the first time the unit is used, or if you wish to change the commands. Otherwise, simply turn the unit on and wait!

FIND LOGO

turn red and green LEDs on

The following procedure is executed for the first and second fields:

wait for interrupt at top of picture
wait for line interrupt
process lines 33 to 96
96

If no logo can be recognised in the external memory, the program remains in this loop; otherwise it jumps to:

ANALYSE LOGO

This process has already been described above, under 'Phase 2'.

MONITOR LOGO

The following procedure is executed for the first and second fields:

wait for interrupt at top of picture
wait for line interrupt
process lines 33 to 96

After processing, execution can proceed in three possible ways.

Logo present
green LED flashes periodically
return to MONITOR LOGO

Logo newly disappeared
red LED flashes periodically
proceed to TRANSMIT IR CODE 1

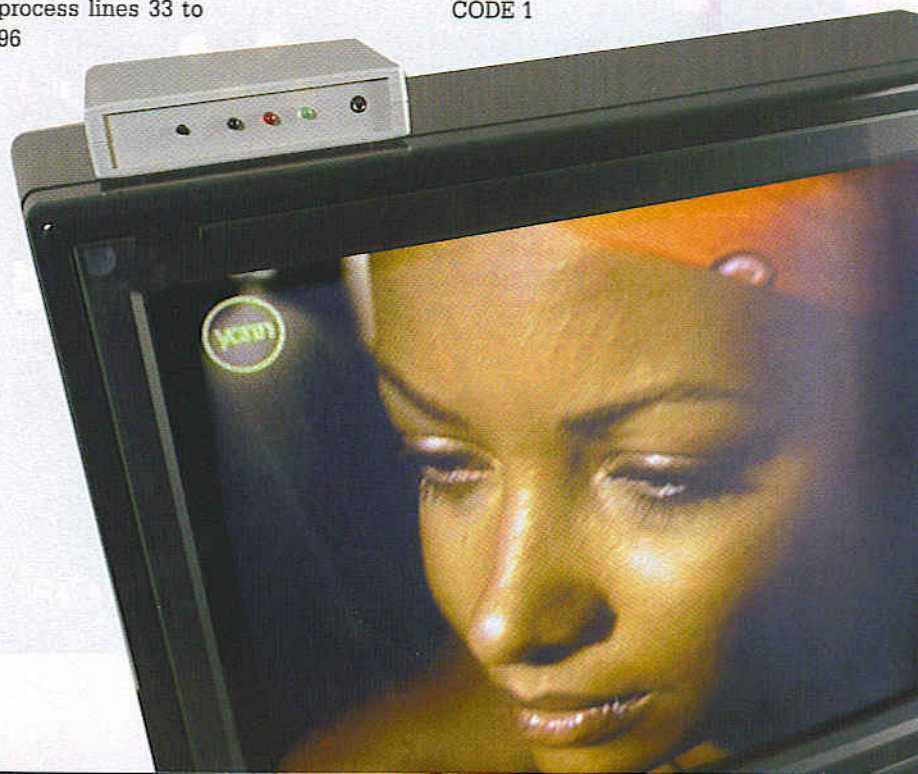

COMPONENTS LIST

Resistors:

(all metal film 0.25 W, 5 %)

R1 = 47Ω
 R2 = 8kΩ
 R3 = 220Ω
 R4,R6 = 100Ω
 R5 = 3kΩ
 R7 = not fitted
 R8 = 120Ω
 R9,R15 = 10kΩ
 R10 = 3kΩ
 R11 = 75Ω

R12 = 620Ω
 R13 = 680kΩ
 R14 = 3kΩ
 R16 = 120kΩ
 R17,R22 = 220kΩ
 R18,R19 = 1kΩ
 R20 = 27Ω
 R21 = 1kΩ

Capacitors:

C1 = 10nF 63V NPO
 C2-C4,C7,C8,C11,C14-C16 = 100nF

63V X7R
 C5 = 220pF 63V NPO
 C6 = 56pF 63V NPO
 C9 = 100pF 63V NPO
 C10 = 510pF 63V NPO
 C12,C13,C18 = 220nF 63V X7R
 C17 = 33pF 63V NPO
 C19-C23 = 10μF 16V E2.5-5
 C24 = not fitted
 C25 = 100μF 16V E2.5-6

Semiconductors:

D1,D2 = 1N4148
 D3 = LED, 5mm, red, low current
 D4 = LED, 5mm, green, low current
 D5 = SFH203FA (Infineon)

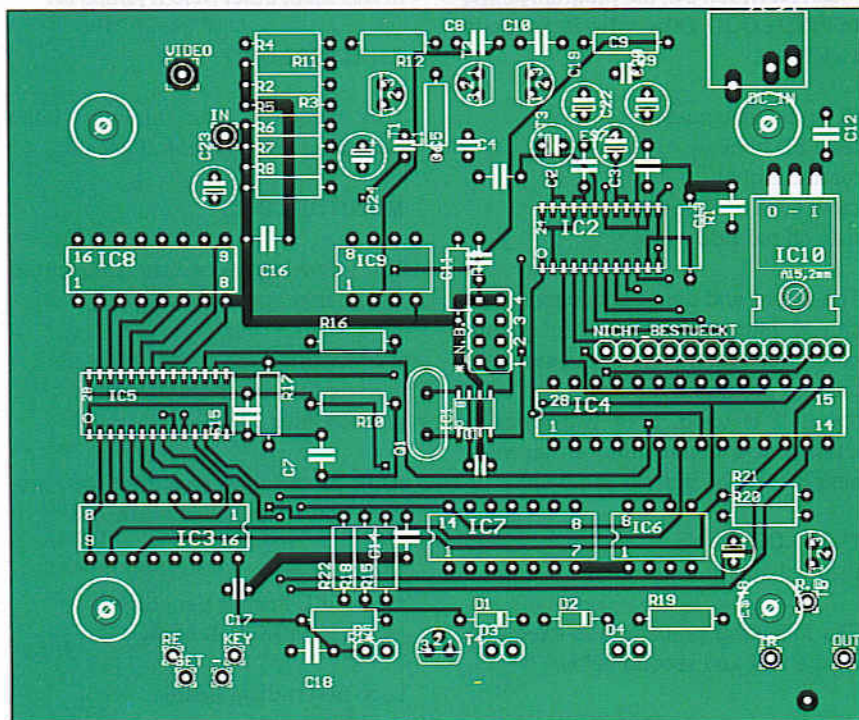
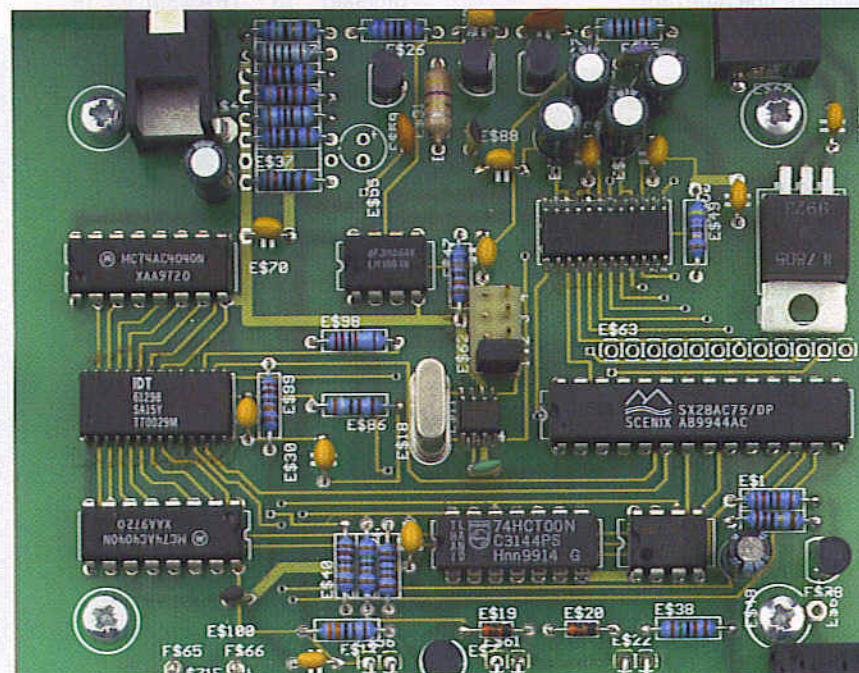

Figure 4. Component mounting plan for the double-sided printed circuit board. The trickiest character to deal with is the SRAM in a 28-pin SOJ package.



Logo newly appeared
 green LED flashes periodically
 proceed to weiter mit TRANSMIT IR
 CODE 2

TRANSMIT IR CODE 1

Fetch first learned infra-red code from
 EEPROM and transmit it three times
 Proceed to MONITOR LOGO

TRANSMIT IR CODE 2

Fetch second learned infra-red code from
 EEPROM and transmit it three
 times
 Proceed to MONITOR LOGO

Construction

The double-sided printed circuit board for the advertisement killer is designed to fit exactly in the suggested enclosure, without the need to wire any of the components using flying leads. Populating the board, as Figure 4 shows, may present a few difficulties, since the clock multiplier, the A/D converter and the RAM are SMDs. The

T1,T3,T4 = BC547B
 T2 = BC557B
 T5 = BC337/40
 LD1 = LD271-H (Infineon/Osram) *
 IC1 = ICS502M (ICS)
 IC2 = ADC1175CIJM (National)
 IC3,IC8 = 74AC4040
 IC4 = SX28AC/DP (Scenix, now Ubicom)*
 IC5 = 61298P6 SOJ28-3 (IDT)
 IC6 = NM24C08N08E (Fairchild)
 IC7 = 74HCT00
 IC9 = LM1881N08E (National)
 IC10 = 78L05

Miscellaneous:

X1 = 20MHz quartz crystal (HC49U-H)
 L1 = 4 μ H7
 K1 = Cinch socket (Lumberg WBTOR 1)
 K2 = mains adaptor socket 2mm (Lumberg NEB/J 21R)
 K3 = miniature jack socket (Lumberg KLBR2)
 S1 = pushbutton with make contact (Schurter 1301.9502, no cap)
 Mains adaptor, 7.5-9 VDC, 300 mA
 Enclosure (e.g., Woehr Bernic Desk Top Enclosure 2011S, www.woehrgmbh.de)

IR transmitter head

Jack plug (Lumberg KLS2SL)
 IR sender LD271-H (Infineon), see above

Suggested supplier

Ing. Büro Schulze
 Obere Ringstrasse 7
 D-79859 Schluchsee
 Germany.
 Tel./fax: +49 7656 9173
 Email Mschulze99@web.de

* hex code file **040051-11**, Free Download,

Figure 5. A jumper is fitted to the programming connector so that a clock is provided to the microcontroller.

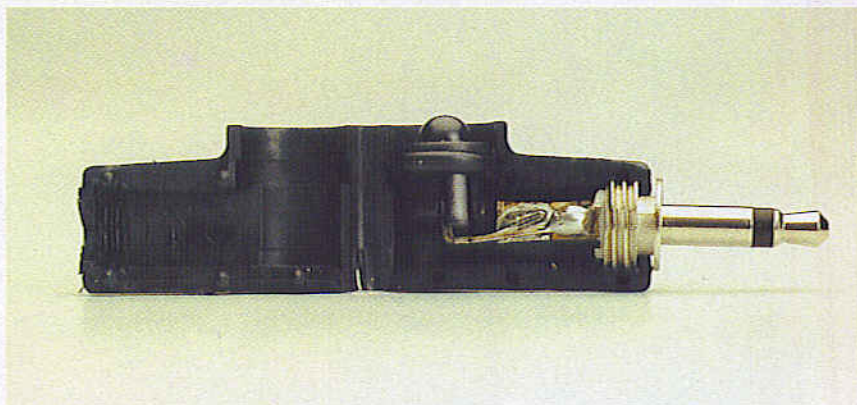
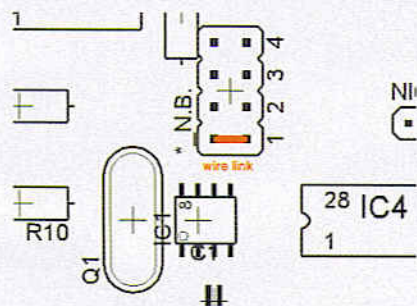

Figure 6. The infra-red transmitter unit is made from a right-angled jack plug, in which the diode is soldered in place of the usual cable.

first two ICs can be soldered using a fine-tipped iron and a steady hand, but the SRAM comes in a SOJ (small outline J-lead) package, whose pins curl under the IC itself. The following highly effective, if somewhat brutal, method is recommended.

1. First fix the device in position on the printed circuit board by carefully soldering two diagonally-opposite pins.
2. Solder all the remaining pins as quickly as possible, not worrying about any solder bridges that may be formed between the pins. A normal rather than a fine-pointed bit is preferable, since it can be used more quickly.
3. Lay a length of solder wick loaded with flux across the soldered connections, and run a hot iron along it, over the pins. With luck all the excess solder will have been removed and the joints will have a

satisfactory appearance. You must of course check that all the solder bridges have been removed. It is important that the wick holds enough flux and that the job is done quickly.

All the other components are of the normal leaded type and should not present any difficulties. Of course, you must observe the correct polarity for diodes, electrolytic capacitors, transistors and ICs.

The header in the middle of the printed circuit board is only required for in-circuit programming of the microcontroller (using the Parallax SX-Key). For normal operation simply fit a jumper in position 1 as shown in Figure 5: this ensures that the clock is provided to the microcontroller.

Finally, Figure 6 shows how the infra-red transmitter is assembled. The transmitter diode is soldered to a jack plug and bent in such a way that the combination can be eased into a right-angled jack plug housing. The diode can be fitted with a plastic clip to ensure that it sits firmly in place. The whole arrangement can be rotated in the socket and so can be pointed accurately at the receiver diode in the recorder.

(040051-1)

Please note: This circuit has not been tested or post-engineered by the Elektor Electronics design laboratory. The use of the Viconti unit described in this article may not be legal in all countries.

MEASUREMENT AND CONTROL

Jürgen Wickenhäuser

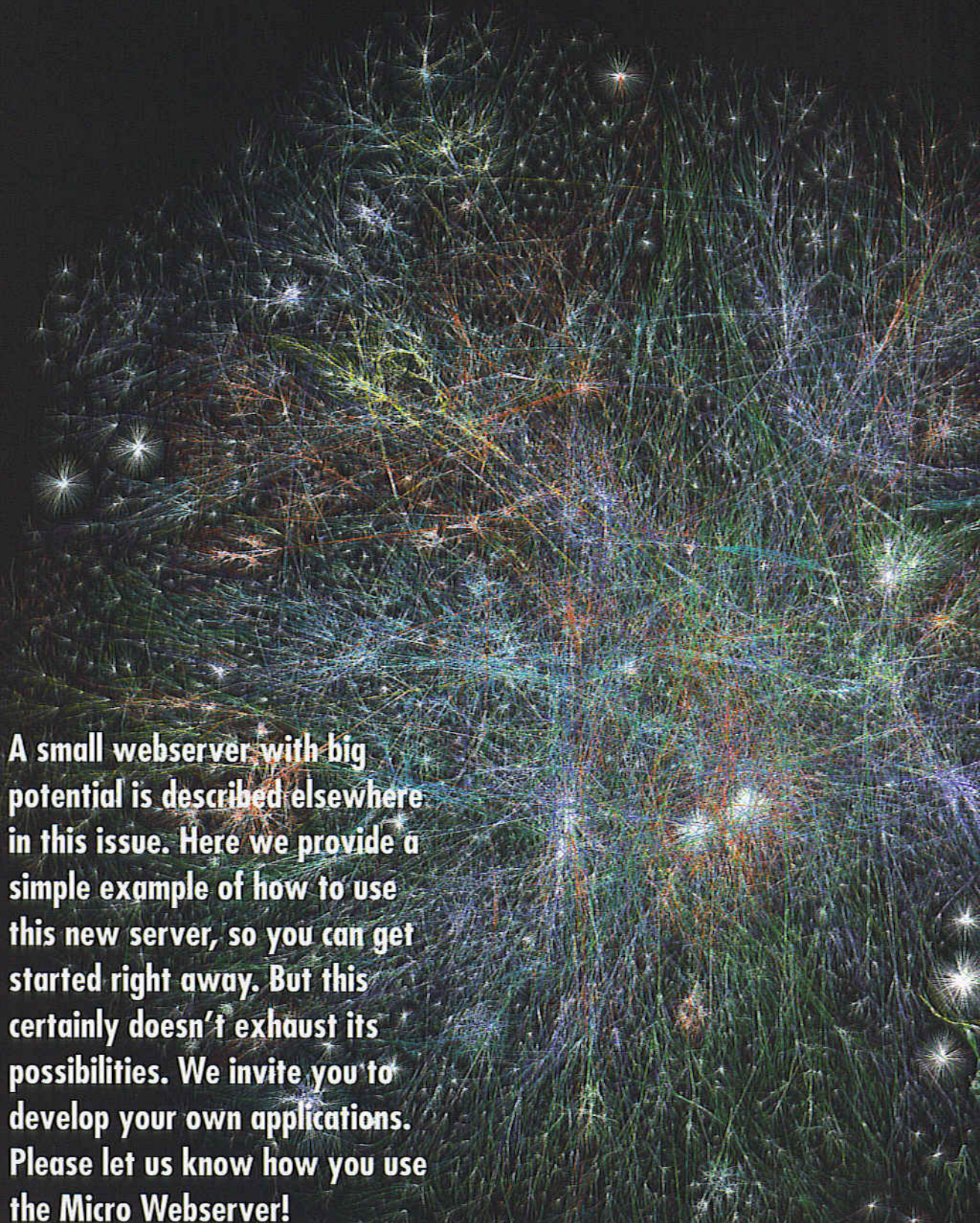

A small webserver with big potential is described elsewhere in this issue. Here we provide a simple example of how to use this new server, so you can get started right away. But this certainly doesn't exhaust its possibilities. We invite you to develop your own applications. Please let us know how you use the Micro Webserver!

VIA THE INTERNET

USING OUR MICRO WEBSERVER

As an example of user-developed applications for the Micro Webserver, here we show how a software clock can be used to incorporate variables from the MSC1210 board in a web page, and how variables on the board can be modified via the Internet. We also show you how to connect an analogue temperature sensor to the board, and we describe the software you need to make the measurements accessible throughout the world via the webserver.

Web pages

After configuring the microcontroller board and network card for proper operation according to the procedure described in the companion Micro Webserver article, you're no doubt keen to conjure up some data on the Internet. With this Micro Webserver, you can do this by using web pages. Websites are generated using the HTML language. HTML code can be generated and edited using any desired text editor. For example, you can use the Notepad, which is a text editor that is supplied with Windows. There are also plenty of alternatives available on the Internet. Special code editors are also available. Such editors can automatically display the HTML code in a different colour, among other things. This is a handy feature, since 'regular' text is clearly distinguished from code, which makes finding errors go a lot faster.

The following is a simple example of a bit of HTML code:

```
<html>
<head>
<title>A simple
page</title>
</head>
<body>
Hello <a
href=http://www.elek-
tor.org>Elektor</a>!
</body>
</html>
```

The result produced by the code for this page is shown in **Figure 1**.

We have no intention of describing all the details here, since innumerable manuals and tutorials can be found on the Internet, and they go into much more detail than we possibly could here. Just try using Google (www.google.com) to search for "HTML manual" or "HTML tutorial".

HTML and the microcontroller

To make data from the microcontroller board visible via web pages, variables must be incorporated into the HTML code. The server then fills these variables with actual data when the code for the web page is executed. With the FlexGate TCP/IP stack, this is very easy. The '@' symbol is used to mark a variable. If you want to use the actual '@' symbol in an HTML page, write '@@' in the code.

Wherever there is a variable in the code, the stack automatically enters the corresponding C variable. The C variable must always have the type string, which means it must be an array of type char. The sample file SET.HTML (**Figure 2**), which is included with the uC/51 compiler, shows how this appears in HTML. This file is required for configuring the server, and it can be downloaded free of charge from the Elektor Electronics website.

In lines 19-21 of this file, you will see the variables hr, min and sec. The current time is set here. Lines 28 and 29 contain the code for check boxes that depend on the values of Is3 and Is4. These two variables contain either 'd' or an empty string. This yields either 'checked' or 'checked', respectively. A feature of most browsers is that they ignore anything they don't recognise. Although this technique is not especially elegant, it means that 'checked' will not be interpreted. As a result, the checkbox will not be ticked if the variable does not contain a 'd'.

Controlling the microcontroller

Of course, users must also be able to modify data in the microcontroller via the Web. In HTML, this is done using structures called 'forms'. Here we use the GET method. This causes the contents of a form to be added to the called URL when it is sent. For instance, if you want to set the clock to 16:29:35 and you click on 'Set Clock', the REPLY.HTML page is called with the following parameters:

```
http://.../reply.html?A1=16&A2=29&A3=35?A9=Set+Clock
```

In this line, '?' marks the start of a parameter string and '&' separates the individual parameters. The '+' symbol indicates a space. Special characters are converted to their equivalent hexadecimal values, which are preceded by '%'. Incidentally, an HTML page can contain several forms, whose parameters are then combined in the URL.

The FlexGate TCP/IP stack assumes that all variables start with 'a' or 'A' (not case-sensitive), followed by a number in the range 1-255.

Associated C code

Now you know exactly how to incorporate variables in the HTML code, but what about the code for the MSC1210? As described in the companion Micro Webserver article elsewhere in this issue, the ELM_FLEX.C file is where users configure the server. In the program loop in which the actual server runs, whenever a page is requested a check is made to see whether specific parameters must be passed with the URL. For example, if an HTML document such as REPLY.HTML is

Suggested applications

The Micro Webserver makes an excellent platform for all sorts of applications where it's handy to be able to observe or control something via the Internet. The following is a list of components and Elektor Electronics circuits that could be used to provide interfaces to the outside world.

A complete weather station can be built using:

- a temperature sensor (using a Pt100 sensor, or digitally with an LM76 or the like)
- a lightning detector (June 2003)
- an anemometer (May 2004)
- a hygrometer (such as the HS1100 used in the January 2004 'Climate Logger' project)
- a rain-barrel gauge ('Rainwater Storage Gauge', December 2000, or 'Precision Level Gauge', December 2001)
- a light intensity sensor (LDR instead of Pt100)

Remote control or monitoring of household appliances and fixtures:

- temperature monitoring (Pt100, LM75A or the like)
- on/off control for a coffee machine, central heating or lighting (with a relay)
- sun awning and roller blind control (with a relay)
- outside lighting (with a relay, possibly with an LDR)
- intruder detection (IR detector from a DIY home improvements shop, or the vibration detector from the December 2002 issue)

Access control with central registration and monitoring, in combination with:

- smart card readers (available from Conrad and other sources)
- light barriers (such as 'Simple Infrared Light Barrier', July/August 2002)
- door openers (electromechanical, from DIY home improvements shops)

Monitoring and controlling machinery

- rpm (see 'Rev Counter for R/C Models' in the November 2003 issue for an idea)
- voltage and current (using a voltage divider or sense resistor and optocoupler via the A/C converter input)
- temperature (Pt100 or LM76 sensor)
- liquid level ('Rainwater Storage Gauge', December 2000, or 'Precision Level Gauge', December 2001)
- flow or discharge (flow sensor, available from Conrad and other sources)
- pressure (pressure sensor, available from Conrad and other sources)
- valve controller (with a relay)
- relay or PWM controller (PWM signal via a solid-state relay)

Centralised data access and data processing, in combination with an LC display

('LC Display with I²C Bus', September 2003) and bar-code reader (from Conrad Electronics or another source)

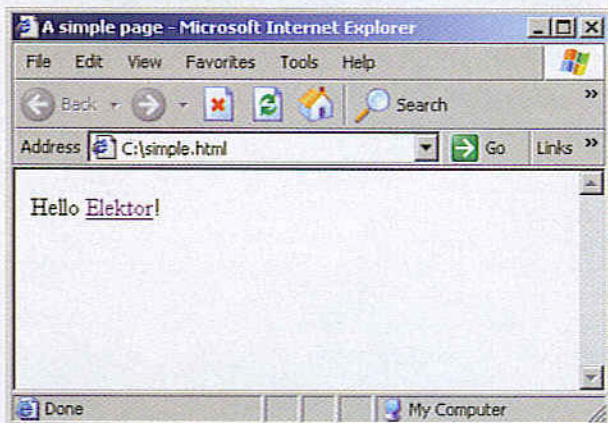

Figure 1.
As shown here, a real web page can be created using a few simple lines of HTML code.

requested, `url_getarg_no()` is used to determine how many parameters are to be passed with the URL. The content is determined using `url_getarg_pc()`. As already mentioned, the only permissible values for the arguments are 'A1'-'A255' and 'a1'-'a255'.

When copying the arguments to local variables, remember that you cannot copy more data than the amount declared for the variable. One of the primary examples is strings in C: here the final '0' byte also counts!

Pt100 temperature measurement

One of the demo pages for the webserver (T_DISP.HTML) makes temperature measurements. Pt100 sensors are espe-

FlexGate TCP/IP stack v2.0

The FlexGate TCP/IP stack used here has been specially developed for 8051-family processors. In contrast to the more elaborate stacks for PCs, its hardware requirements are quite modest. A complete webserver can be set up using less than 1 kB of RAM and approximately 12 kB of code. The stack is open-source software, which means the source code is freely available. In its basic configuration, this stack can handle the most important Internet protocols, which are ICMP, ARP, PING, TCP and UDP. All that

has to be added for a webserver is ARP and TCP. With the FlexGate TCP/IP stack, in principle any desired number of concurrent connections is possible.

The stack is integrated into the uC/51 compiler. This is a complete development environment for ANSI C (see reference [1]). The demo version is normally restricted to 8 kB of code, but for the Micro Webserver the limit is automatically increased to 16 kB.

cially suitable for this purpose. As the MSC1210 provides a precise reference voltage and its A/D converter can be calibrated using the same voltage, any inaccuracies that may be present do not affect the measurement results.

If you use a precision resistor and Pt100 sensor (DIN class 1/3 is the most suitable), you don't even have to calibrate the circuit. If the components are not so precise, you can achieve a perfectly adequate calibration using an ice-water bath (0°C) and a warm-water bath at approximately 40°C with a fever thermometer.

Unfortunately, Pt100 sensors are not fully linear, but with the indicated component values the error is within 0.5°C over the range of -10°C to +50°C (see **Figure 3**).

As a constant current of approximately 2 mA flows through the Pt100 sensor, a certain amount of self-heating can occur with types having a small package. This is often stated in the data sheet where relevant. The voltage divider incorporating the Pt100 sensor is connected to the U_{ref}, AIN7 and AGND/AINCOM terminals of the MSC1210 board (see **Figure 4**).

Processing the measurement data

The ELMET.C file contains not only initialisation subroutines, but also interrupt subroutines. The software clock and the A/D converter both work with interrupts. This is used to continuously maintain the value measured by the A/D converter in a temporary variable of type long. To save computation time, this value is only converted into a temperature after it reaches ELM_FLEX.C. The macro AD_FILTER can be used to configure the A/D converter to always return the average value of several measurements.

In this simple demo program, the A/D converter is calibrated once only using set adval bip(). However, for reliable measurements it's a good idea to regularly recalibrate the A/D converter, such as every few minutes. One way to do this is to call the initialisation routine in the main loop if a flag is set by the interrupt routine for the software clock. This method is better than calling the function directly in the interrupt routine. This is because as a matter of principle the interrupt routine should be exited as quickly as possible, in order to avoid delays in responding to any other interrupts.

Conclusion

The software clock and making temperature measurements using a Pt100 sensor with the A/D converter are simply two sample applications. Naturally, the server can be used to implement just about any task you can imagine. Some of the possible applications we can think of are listed in the 'Suggested applications' box. This list is far from complete, and it is actually intended to stimulate you to use the MSC1210 board and the new network interface to develop your own applications. We're very much interested in seeing your ideas. We'll certainly report all the attractive, interesting and clever applications in *Elektor Electronics*. And as always, we always reward applications suitable for publication with a suitable payment. Let us hear from you at editor@elektor-electronics.co.uk, subject: Micro Webserver.

(040147-1)

Figure 2. SET.HTM displayed in the AceHTML editor window.

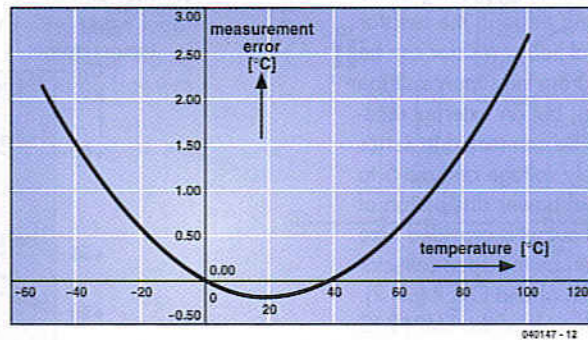

Figure 3. Non-linearity of the Pt100 temperature sensor.

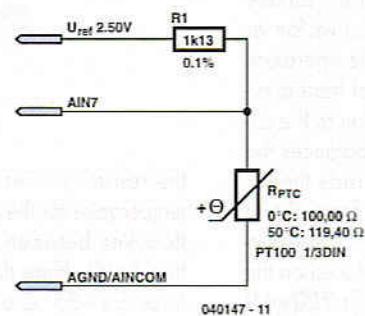

Figure 4. Connecting the temperature sensor to the reference voltage and A/D converter.

Internet references

- [1] www.wickenhaeuser.com
A uC/51 compiler with source code
- [2] www.ti.com/msc The MSC121x home page
- [3] groups.yahoo.com/group/TI-MSC
MSC121x users group. Definitely worth the effort. Free, but registration is required.
- [4] freeware.acehtml.com
Free HTML editor. Registration not necessary.

Airflow Monitor

Gregor Kleine

Fans are usually monitored by measuring their operating currents. If the current lies within a certain range, it is assumed that the fan is spinning properly and providing a stream of cooling air. If it falls below a lower threshold or exceeds an upper threshold, something is wrong with the fan: it is either defective or blocked by some sort of object.

The cooling airflow generated by a fan can be directly monitored using the Analog Devices TMP12 sensor IC (www.analog.com). This IC contains a temperature sensor and a heater resistor, as well as two comparators and a reference-voltage source. **Figure 1** shows the complete circuit diagram of an airflow monitor. The voltage divider formed by R1, R2 and R3 defines the temperature thresholds and the hysteresis for the switching points (via the current I_{REF} flowing through the resistor chain). The internal heater resistor can be powered directly from the supply voltage via pin 5 (Heater), but an external resistor (R5) can also be connected in series between the supply voltage and pin 5 to reduce the internal power dissipation of the IC. The circuit output is provided here by two LEDs driven by the open-collector outputs UNDER (pin 6) and OVER (pin 7). The operating principle of the TMP12 IC is that it is warmed by the integrated heater resistor and cooled by the air flow. If there is no airflow or the airflow is insufficient due to a defective fan or obstructed air inlet, the temperature increases until the amount of heat dissipated by the IC (by conduction to the circuit board or other means) balances the amount of heat generated inside the IC.

Figure 2 shows this in the form of two curves. The power dissipation of the internal 100-Ω heater resistor is plotted on the X axis. This can be as much as 250 mW if pin 5 is connected directly to +5 V. If the heater resistor is not dissipating any power, the sensor will be at approximately ambient temperature, which is here taken to be +50 °C. If the power dissipated by the heater resistor increases, the level to which the temperature of the IC will rise can be read from the two curves, which show the situation with and without cooling airflow. As indicated, the temperature thresholds T_{SETHIGH} and T_{SETLOW} are dimensioned such that with the amount of power converted into heat by

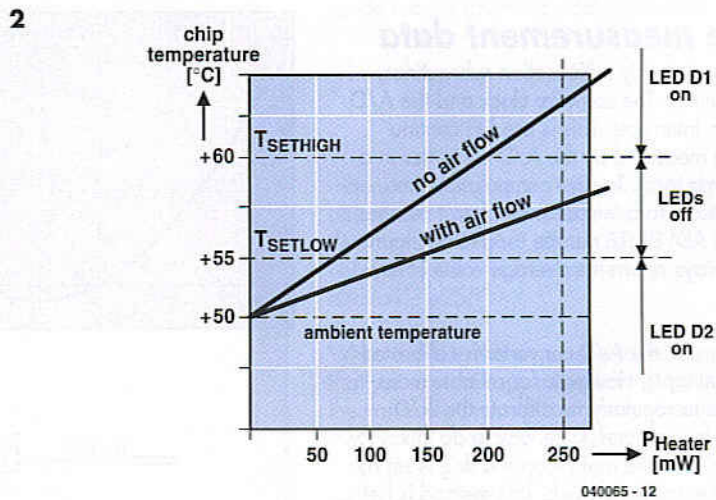
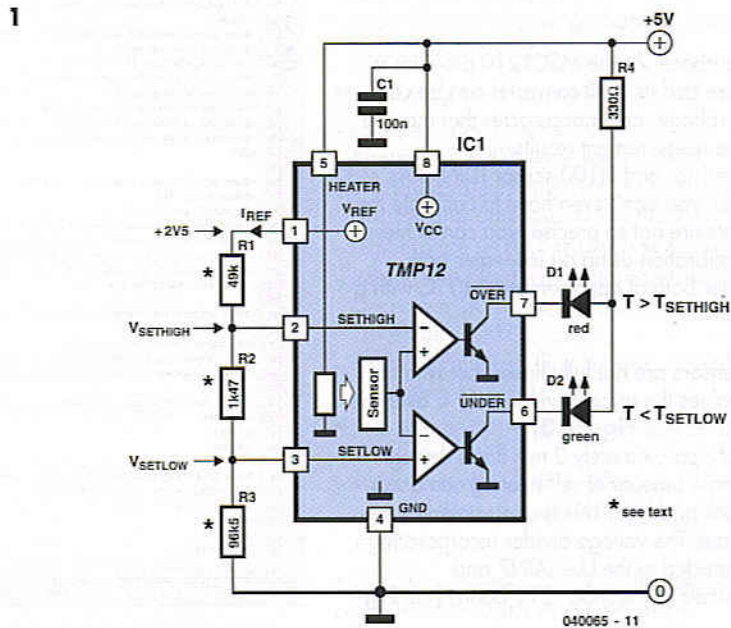

the resistor (in this case, 250 mW), the temperature for the curve with cooling airflow lies between the two temperature thresholds. Here the threshold temperatures are +55 °C and +60 °C. The voltage divider R1/R2/R3 determines not only the absolute positions of the temperature thresholds, but also the hysteresis of the switching points. The hysteresis is determined by the current I_{REF} flowing through the resistor chain. The associated formulas are shown in **Figure 3**. Here ΔT is the hysteresis, which in this case is set to 2 °C and yields a value of 17 μA for I_{REF}. The node voltages for the voltage divider can now be determined from the threshold temperatures, which in this case yields V_{SETHIGH} = 1.666 V for an upper threshold

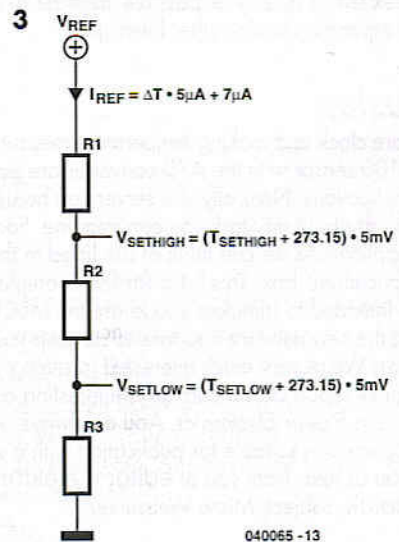

of +60 °C and $V_{SETLOW} = 1.641$ V for a lower threshold of +55 °C. As $V_{REF} = 2.5$ V, the values of R1, R2 and R3 can now be readily calculated from the current and the voltage drops across the resistors. The values calculated in this manner are shown in the schematic diagram, without taking into account whether such values are actually available. As the temperature thresholds used here are relatively close together, the

actual values of the resistors must be quite close to the calculated values. This can be achieved by connecting standard-value fixed resistors in series and/or parallel, or by using trim pots.

The TMP12 can be used to generate digital monitoring signals for a processor or switch on a supplementary fan (via a driver stage connected to the outputs). Another possible application is controlling

an oven that is switched off by the TMP12 when it reaches its set-point temperature. Such an oven can be used to operate a crystal oscillator at an elevated temperature in order to make it insensitive to temperature variations (a crystal oven). According to its data sheet, the IC can be used at temperatures between -40 °C and +125 °C.

(040066-1)

Zero Gain Mod for Non-Inverting Opamp

Flemming Jensen

Electronics textbooks will tell you that a non-inverting opamp normally cannot be regulated down to 0 dB gain. If zero output is needed then it is usual to employ an inverting amplifier and a buffer amp in front of it, the buffer acting as an impedance step-up device.

The circuit shown here is a trick to make a non-inverting amplifier go down all the way to zero output. The secret is a linear-law stereo potentiometer connected such that when the spindle is turned clockwise the resistance in P1a increases (gain goes

up), while the wiper of P1b moves towards the opamp output (more signal).

When the wiper is turned anti-clockwise, the resistance of P1a drops, lowering the gain, while P1b also supplies a smaller signal to the load. In this way, the output signal can be made to go down to zero.

(030126-1)

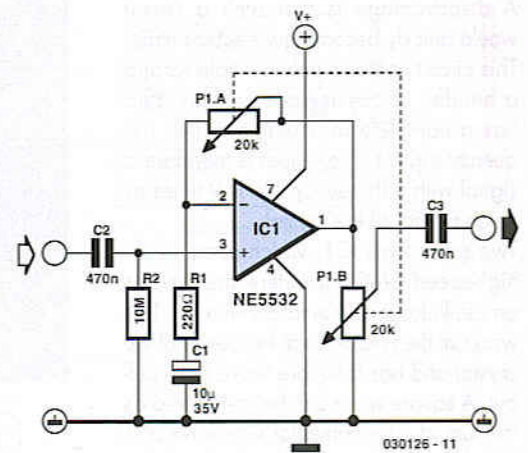

030126 - 11

Simple Darkness Activated Alarm

Myo Min

Most darkness activated alarms employ opamps and some logic ICs. Here, a less expensive approach is shown based on the eternal 555, this time in monostable multivibrator mode. Components R2 and C1 represent a one-second network. When the LDR (light dependent resistor) is in the dark, its resistance is high, pulling pin 2 of the 555 to ground. This triggers the monostable and the (active!) 6-volt piezo buzzer will sound. Preset P1 is adjusted depending on ambient light levels.

The circuit may be fitted on a wall in your home. Assuming P1 has been set for the

existing ambient light level, the shadow cast by anybody entering the room or hallway will trigger the alarm.

(030130-1)

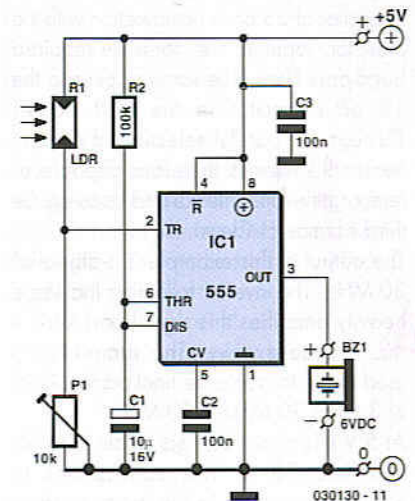

030130 - 11

CMOS Crystal Frequency Multiplier

Gert Baars

Crystals usually operate at fundamental frequencies up to about 15 MHz. Whenever higher frequencies are required a frequency multiplier is placed after the crystal oscillator. The resulting output signal is then a whole multiple of the crystal frequency. Other frequency multipliers often use transistors, which produce harmonics due to their non-linearity. These are subsequently filtered from the signal. One way of doing this is to put a parallel LC filter in the collector arm. This filter could then be tuned to three times the input frequency. A disadvantage is that such a circuit would quickly become quite substantial. This circuit contains only a single IC and a handful of passive components, and has a complete oscillator and two frequency triplers. The output is therefore a signal with a frequency that is 9 times as much as that of the crystal.

Two gates from IC1, which contains six high-speed CMOS inverters, are used as an oscillator in combination with X1. This works at the fundamental frequency of the crystal and has a square wave at its output. A square wave can be considered as the sum of a fundamental sine wave plus an infinite number of odd multiples of that wave. The second stage has been tuned to the first odd multiple (3 x).

We know that some of our readers will have noticed that the filter used here is a band-rejection (series LC) type. Worse still, when you calculate the rejection frequency you'll find that it is equal to the fundamental crystal frequency! The fundamental frequency is therefore attenuated, which is good. But how is the third harmonic boosted? That is done by the smaller capacitor of 33 pF in combination with the inductor. Together they form the required band-pass filter. (The same applies to the 12 pF capacitor in the next stage.) Through the careful selection of components, this filter is therefore capable of rejecting the fundamental and boosting the third harmonic! Clever, isn't it?

The output in this example is a signal of 30 MHz. The inverter following this stage heavily amplifies this signal and turns it into a square wave. The same trick is used again to create the final output signal of 3 times 30 MHz = 90 MHz.

At 5 V this circuit delivers about 20 milliwatt into 50 Ω . This corresponds to +13 dBm and is in theory enough to

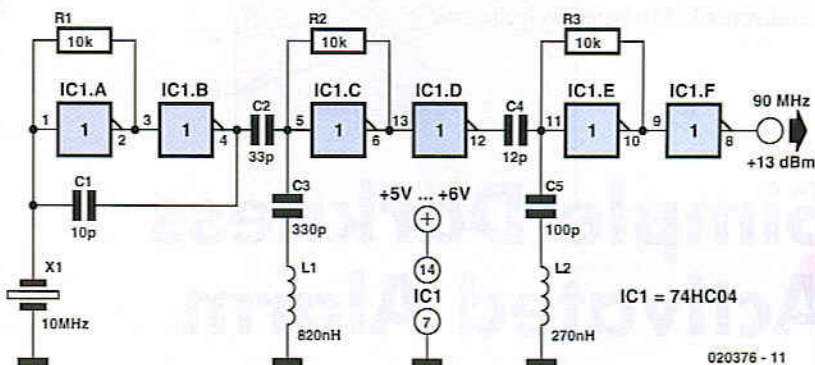
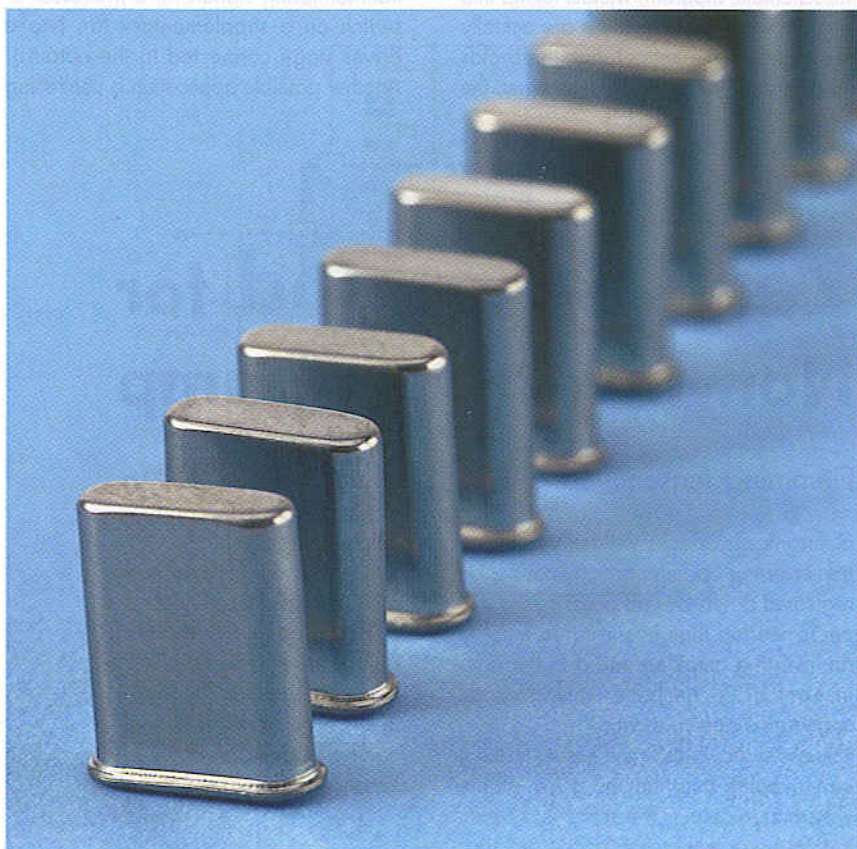

020376 - 11

drive a diode-ring balanced mixer directly. The circuit can be used for any output frequency up to about 100 MHz by varying the component values. When, for example, an 8 MHz crystal is used to obtain an output frequency of 72 MHz ($9 \times 8 = 72$), the frequency determining inductors and capacitors have to be adjusted by a factor of 10/8. You should round the values to the nearest value from the E12 series.

Another application is for use in an FM transmitter; if you connect a varicap in series with the crystal, you can make an FM modulator. An added bonus here is that the relatively small modulation level

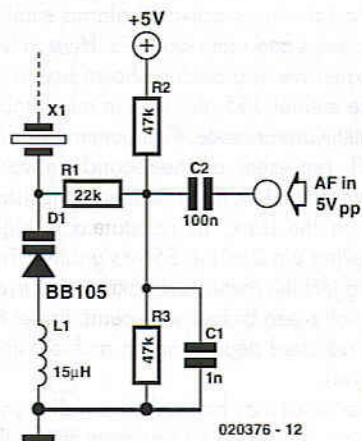

020376 - 12

is also increased by a factor of 9. Crystals with frequencies near 10 MHz are relatively easy to find and inexpensive, so you should always be able to find a suitable frequency within the FM band. A

crystal of 10.245 MHz for instance would give you a frequency of 92.205 MHz and 10.700 MHz results in an output of 96.300 MHz. You may find that the circuit operates on

the border of the HC specifications. If this causes any problems you should increase the supply voltage a little to 6 V.

(020376-1)

Doorbell Cascade

René Bosch

Sometimes you have to do it the hard way, even if doing it the easy way is an option. That is the case here. The intention is to add a second doorbell in parallel with the existing bell. This does not, in principle, require any electronic components. You would simply connect the second bell to the first one. But if the existing bell transformer is not rated for the additional load then this is not a good idea! An option is to buy a new and larger transformer. But bigger also means more expensive! Moreover, replacing the existing transformer can be an awkward job, for example when it is built into the meter box.

So we follow different approach. This circuit is connected in parallel with the existing bell. This is possible because the current consumption is very small compared to the load of the bell. The bridge rectifier rectifies the bell voltage when the push-button is pressed. This will then close the

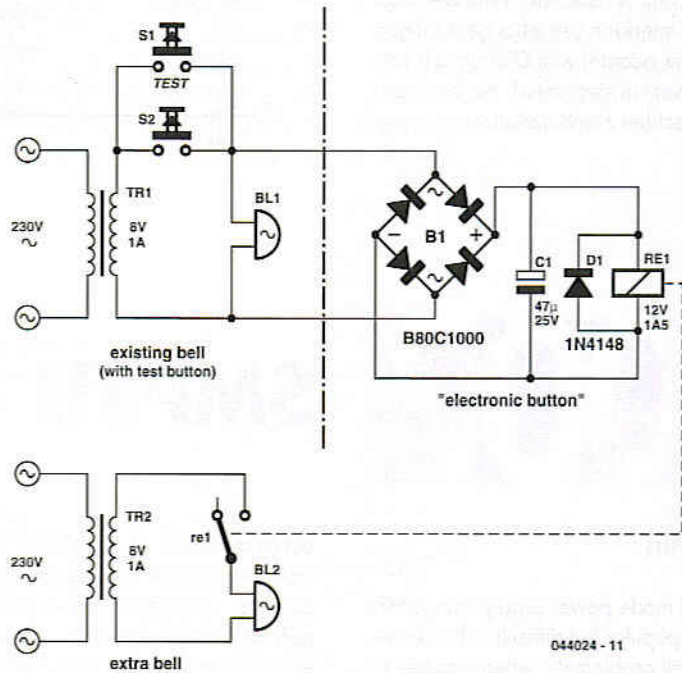

044024 - 11

relay contacts. These contacts are the 'electronic' button for the second bell,

which is powered from its own cheap bell transformer.

(044024-1)

Switchless NiCd/NiMH Charger

Myo Min

This circuit may be used to replace the single current limiting resistor often found in dirt cheap battery chargers. The alternative shown here will eventually pay off because you no longer have to throw away your NiCds after three months or so of maltreatment in the original charger. The circuit diagram shows an LM317 in constant-current configuration but without the usual fixed or variable resistor at the

ADJ pin to determine the amount of output current. Also, there is no switch with an array of different resistors to select the charge currents for three cell or battery types we wish to charge: AAA, AA and PP3 (6F22).

When, for example, an empty AAA cell is connected, the voltage developed across R1 causes T1 to be biased via voltage dropper D1. This results in about 50 µA flowing from the LM317's ADJ pin

into the cell, activating the circuit into constant-current mode. D4 is included to prevent the battery being discharged when the charger is switched off or without a supply voltage.

The charging current I is determined by $R1/R3/R3$ as in

$$R(n) = (1.25 + V_{sat}) / I$$

where V_{sat} is 0.1 V.

The current should be one tenth of the nominal battery capacity — for example, 170 mA for a 1700-mAh NiCd AA cell. It should be noted that 'PP3' rechargeable batteries usually contain seven NiCd cells so their nominal voltage is 8.4 V and not 9 V as is often thought.

If relatively high currents are needed, the power dissipation in R1/R2/R3 becomes an issue. As a rule of thumb, the input voltage required by the charger should be greater than three times the cell or battery (pack) voltage. This is necessary to cover the LM317's dropout voltage and the voltage across R(n).

Two final notes: the LM317 should be fitted with a small heat sink. With electrical safety in mind the use of a general-purpose mains adapter with DC output is preferred over a dedicated mains transformer/rectifier combination.

(040002-1)

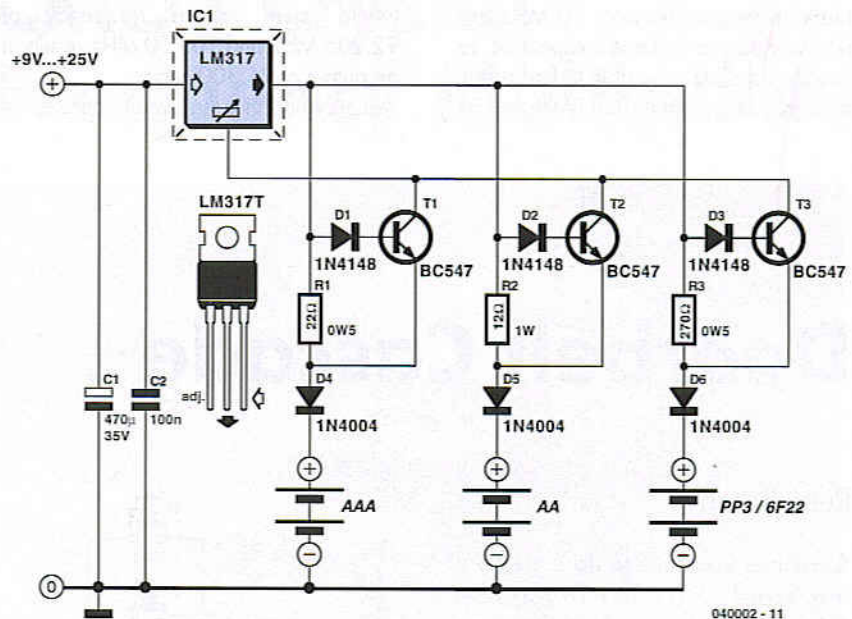

040002 - 11

007

SMPSU with a Relay

Myo Min

Switched mode power supply units (SMPSUs) are popular but difficult to build oneself as well problematic when it comes to understanding their design principles. Building your own SMPSU typically requires a lot of expertise, hard to find components and time. The circuit shown here is educational only and devised to demonstrate the principle of the step-up switch mode circuits. It is not intended to be incorporated in a 'real' design. Relay Re1 has a normally-closed (NC) change-over contact and is connected to

act as a vibrator. When power is applied to the circuit, the relay is energized and actuates its contact. This action may appear to break the circuit. However, the energy stored in the relay coil will produce an induced voltage which is fed to D1 and C1 for rectification and smoothing. The output voltage will be of the order of 150 V and strongly dependent on the type of relay used. In general, the faster the relay, the higher the output voltage. The circuit will oscillate at a low frequency (100-200 Hz), and a buzzing sound will be heard from the relay.

(030129-1)

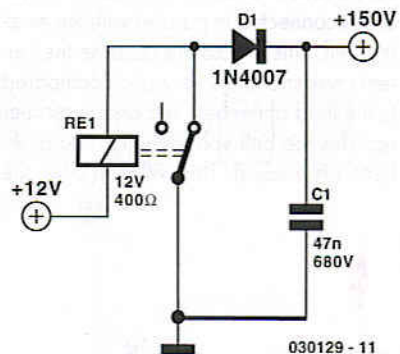

030129 - 11

008

100 V Regulators

Gregor Kleine

Standard three-legged voltage regulator chips like the LM317 can cope with an input voltage of up to about 30 V, a few

high-voltage types can handle 60 V but if that is still not sufficient for your application the company Supertex (www.supertex.com) produce devices that can withstand much higher input voltages. The reg-

ulator type LR8 has a maximum input voltage of 450 V and can supply an output current of 20 mA. The LR 12 has a better output current of 50 mA but with a maximum input voltage of 100 V, and the out-

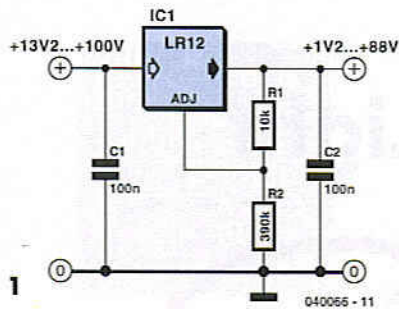

2

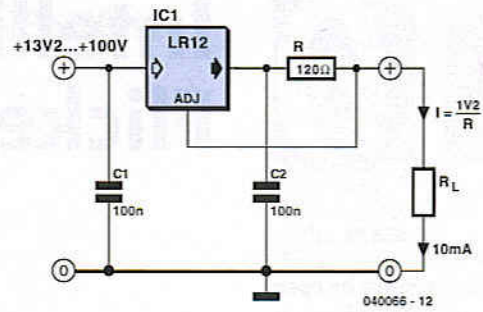

put voltage can be adjusted up to 88 V. The output voltage is defined by a potential divider chain connected between the output and the ADJ (adjust) input pin. The regulator simply changes its output voltage until the divided voltage at the ADJ input is equal to 1.2 V. The output voltage can be more precisely expressed as a function of R1 and R2 in the formula: $V_{OUT} = 1.2 V [1 + (R2/R1)]$

$$R2 = R1 \cdot [(V_{OUT}/1.2 V) - 1]$$

The current through R1 and R2 must be greater than 100 μ A. Just like conventional voltage regulators the LR12 can also be configured as a constant current source. Again the regulator simply adjusts its output voltage until it measures 1.2 V at the ADJ input. For a constant current of 10 mA the value of the

series resistor is equal to the resistance that will produce a voltage drop of 1.2 V when 10 mA passes through it. As mentioned above the maximum output current is limited to 50 mA. A capacitor of 100 nF is necessary at the output to ensure stable regulator operation. The LR12 is available in SO-8, TO-92 and TO-252/D-PAK outlines.

(040066-1)

Stepper Motor Generator

009

Stepper motors are a subject that keeps recurring. This little circuit changes a clock signal (from a square wave generator) into signals with a 90-degree phase difference, which are required to drive the stepper motor windings. The price we pay for the simplicity is that the frequency is reduced by a factor of four. This isn't really a problem, since we just have to increase the input frequency to compensate.

The timing diagram clearly shows that the counter outputs of the 4017 are combined using inverting OR gates to produce two square waves with a phase difference. This creates the correct sequence for powering the windings: the first winding is negative and the second positive, both windings are negative, the first winding is positive and the second negative, and finally both windings are positive. Internally, the 4017 has a divide-by-10 counter followed by a decoder. Output '0' is active (logic one) as long as the internal counter is at zero. At the next positive edge of the clock signal the counter increments to 1 and output '1' becomes active. This continues until output '4' becomes a logic one. This signal is connected to the reset input, which immediately resets the counter to the 'zero' state. If you were to use an oscilloscope to look at this output, you would have to set it up

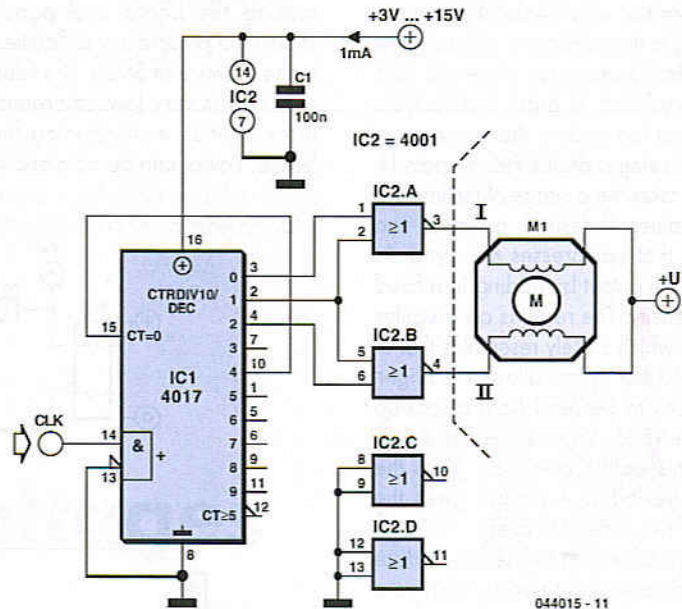

044015 - 11

very precisely before you would be able to see this pulse; that's how short it is. The output of an OR gate can only supply several mA, which is obviously much too little to drive a stepper motor directly. A suitable driver circuit, which goes between the generator and stepper motor, was published in the May 2004 issue of *Elektor Electronics*.

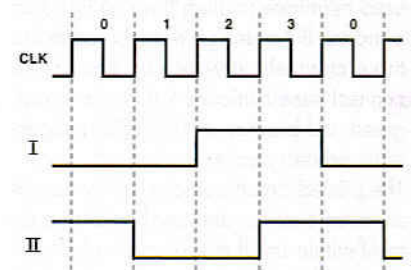

(044015-1)

044015 - 12

Intelligent Flickering Light

Andre Frank

Whether it is required to simulate an open fire in a nativity scene, a forest fire in a model railway landscape, a log fire in a doll's house or simply for an artificial candle, neither steady light nor the commercially-available regularly flickering lights are very realistic. The circuit described here imitates much better the irregular flickering of a fire.

For maximum flexibility, and to reduce the component count to a minimum, a microcontroller from the Atmel ATtiny range has been selected to generate the flickering pattern. Two miniature light bulbs, each driven by a transistor, are controlled using a PWM signal to produce eight different light levels. Potentiometer P1 in the RC network adjusts the speed of the clock to the microcontroller, and hence the speed of the flickering.

Generating the light levels in software is straightforward in practice, but the underlying theory is far from simple: hence the 'intelligent' in the title. Using a digital pseudo-random number generator (an 8-bit shift register with feedback arranged according to the coefficients of a primitive polynomial) a sequence of period 255 can be produced. In order that the flickering is not too violent, the sequence is smoothed using a digital FIR low-pass filter which takes the average of the last two sample values. If desired, a jumper can be fitted that compresses the dynamic range of the output by adding in a fixed basic intensity. The result is an irregular flickering which closely resembles that of a fire. A further option allows the brightness values to be read from a look-up table instead of using the sequence generator; this option obviously gives the greatest flexibility. A jumper gives the choice of two different tables.

The look-up tables can be used to produce other decorative light effects, such as a light fader, or the continuous mixing of two differently-coloured lights. It could even be used to imitate rotating flashing lights on a model. If the design were expanded to three channels, it would be possible to connect three miniature light bulbs in red, green and blue (or an RGB LED) and generate arbitrary colour patterns.

The printed circuit board is just the size of a postage stamp and so should be easy to fit within small models or model landscapes. The board is single-sided, and

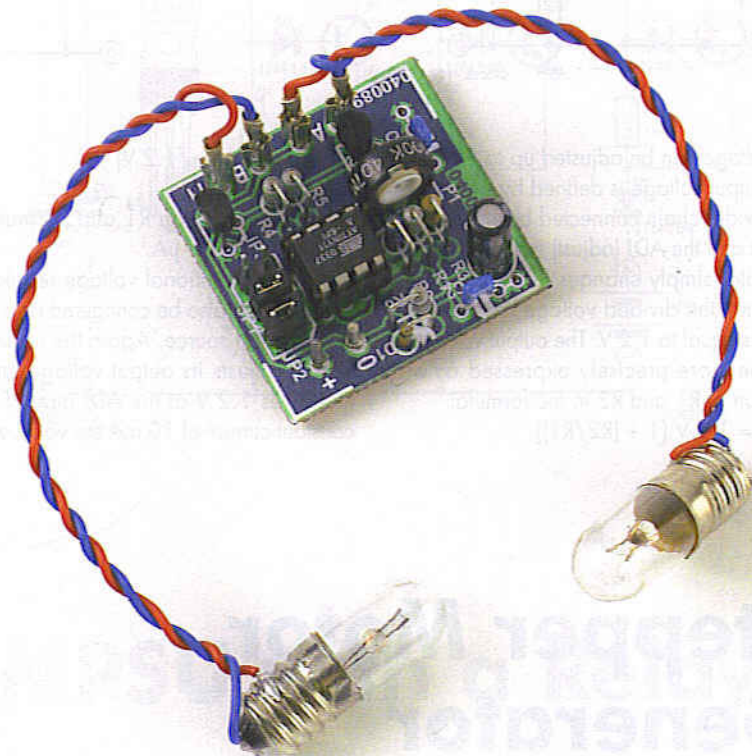

making the board and populating it should not present any difficulties, thanks to the absence of SMDs. The total component cost is very low, at around two or three pounds, not including the circuit board. Power can be obtained from any

regulated 5 V supply. If only an unregulated supply is available, then this should be connected to V+. Current consumption is of course mostly dependent on the choice of lamp.

(040089-1)

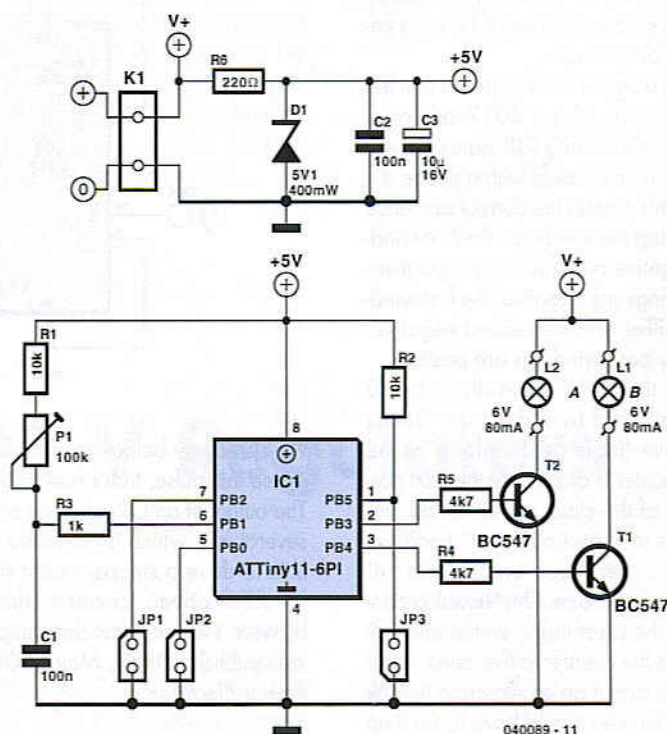

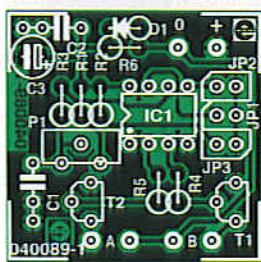

COMPONENTS LIST

Resistors:

R1, R4, R5 = 4k Ω
 R2 = 10k Ω
 R3 = 1k Ω
 R6 = 220 Ω

Capacitors:

C1, C2 = 100nF
 C3 = 10 μ F 16V

Semiconductors:

D1 = 5.1V zener diode, 400 mW
 T1, T2 = BC547
 IC1 = ATtiny11-6PI (programmed)

Miscellaneous:

L1, L2 = 6V / 80mA miniature lamp
 PCB no. 040089-11, available from
The PCBShop
 Project software: file **040089-11**, Free
 Download

The Eternal 555

Karel Walraven

You may not realise this, but the 555 timer IC has been in existence for over 30 years. The chip was originally manufactured by Signetics. In the first three months following its introduction (1972) over half a million of them were sold. Moreover, it has stayed successful: since that time the 555 has been the most popular IC sold every year! Nowadays it makes sense to use the CMOS version of this IC, since it consumes significantly less power.

Virtually everything regarding the 555 can be found at www.schematica.com/555_Timer_design/555.htm. A program can be downloaded from this site, which easily calculates the values for the R-C components. The program is suitable for both the astable and bistable modes. The

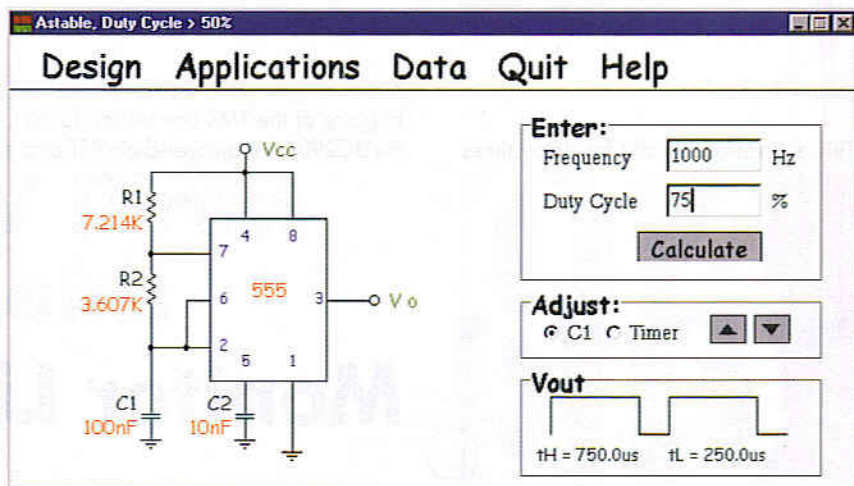

'adjust' buttons are used to switch between the single 555 and the double version (the 556). When a different value

is chosen for C1, the resistors change automatically.

(044020-1)

Reset IC with Selectable Voltages

Gregor Kleine

Modern digital systems work with a supply voltage of +3.3 V, and sometimes they also need an additional, lower supply voltage, such as 1.8 V, 1.5 V or even 1.2 V. To generate a reset signal from these two voltages, it was previously necessary to use a separate reset IC for each voltage, and each IC had to be individually dimensioned for the voltage it monitored.

The Linear Technology LTC2904/5 (www.linear.com/pdf/29045f.pdf) can be programmed for two voltages. The voltages are selected using the S1, S2 and TOL inputs according to whether they are connected to V1, connected to ground or left open. The IC can be configured for the voltages shown in the table. The tolerance for the two voltages can be set using the TOL pin. The effect this has on the internally determined reset threshold is that the larger the tolerance, the lower

the internal threshold is set.

The \overline{RST} output (pin 3) is an open-drain output. It goes Low when at least one of the two voltages drops below the programmed threshold level. There is a time delay before the reset signal is de-activated after the voltages rise above the threshold level. With the LTC2904, this delay has a fixed value of 200 ms, while with the LTC2905 it depends on the value of the capacitor connected to the TMR pin:

S1	S2	V1	V2
V1	V1	5.0 V	3.3 V
open	ground	3.3 V	2.5 V
V1	open	3.3 V	1.8 V
open	V1	3.3 V	1.5 V
open	open	3.3 V	1.2 V
ground	ground	2.5 V	1.8 V
ground	open	2.5 V	1.5 V
ground	V1	2.5 V	1.2 V
V1	ground	2.5 V	1.0 V

TOL	Tolerance
V1	5 %
open	7.5 %
ground	10 %

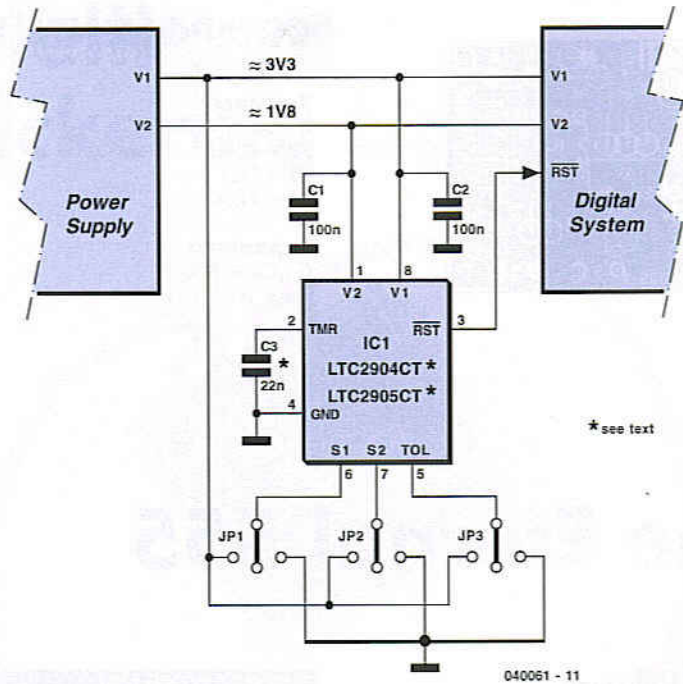

$t_{delay} = 9 \text{ ms/nF}$

This expression is valid for delay times

between 1 ms and 10 s.

In place of the TMR connection (pin 2), the LTC2904 has an open-drain RST output

that is complementary to the $\overline{\text{RST}}$ output, which means it is active High.

(040061-1)

013

Monitor Life Xtender

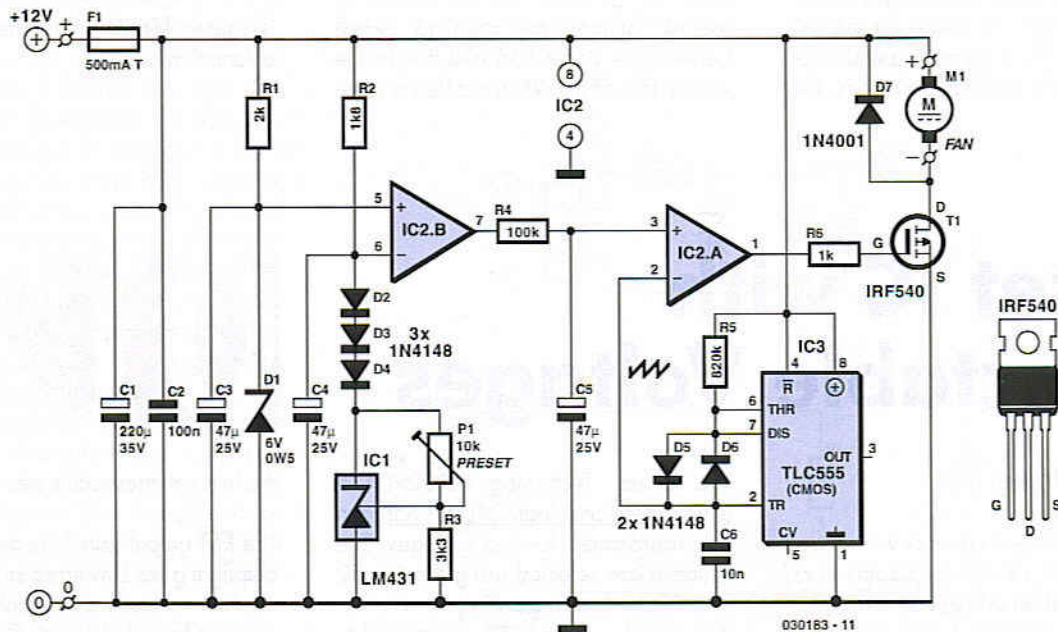

Myo Min

This circuit was designed to protect a computer monitor from overheating. It is recommended to attach this circuit to

power users' monitors! Most computer monitors of the CRT type fail owing to over-heating. After one or two hours of use, the rear of a monitor may become as hot as 45 degrees C, or

20 degrees above ambient temperature. Most heat comes from the VGA gun drivers, the horizontal circuit, vertical circuit and power supply. The best possible way to extract heat and so prolong mon-

itor life (and save the environment) is to add a brushless fan, which is lighter, energy-wiser and more efficient than a normal fan.

In the diagram, diodes D2, D3 and D4 sense the monitor's temperature. These diodes have a total negative temperature coefficient of 6 mV per degree Celsius. To eliminate noise, shielded wire should be used for the connection of the temperature sensor to the circuit sensor.

The +12-V supply voltage is borrowed from the computer's power supply. Alternatively, a mains adapter with an output of 12 VDC may be used. C1 and C2 are decoupling capacitors to eliminate the ripple developed by switching or oscillation. R1 provides bias current to D1, a 6-V zener diode acting as a reference on the non-inverting pin of opamp IC2.B. IC1, a 'precision shunt regulator' raises the sensor

diodes' voltage to just over 6 V depending on the adjustment of P1. C4 is the decoupling capacitor with the sensor network. Integrator network R4-C5 provides a delay of about 3 seconds, transforming the on/off output signal of IC2.B into an exponentially decreasing or increasing voltage. This voltage is fed to pin 3 of the second opamp, IC2.A.

The hard on/off technique would produce a good amount of noise whenever the load is switched, hence an alternative had to be found. IC3, a TLC555, is used as an astable multivibrator with R5 and C6 controlling the charging network that creates a sawtooth voltage with a frequency of about 170 Hz. This sawtooth is coupled to pin 2 of IC2.A, which compares the two voltages at its input pins and produces a PWM (pulsewidth modulated) output voltage. The sawtooth wave

is essential to the PWM signal fed to power output driver T1 by way of stopper resistor R6. The power FET will switch the fan on and off fan according to the PWM drive signal.

The back emf pulses that occur when T1 switches on and off are clamped by a high-speed diode, D7.

Initially, turn P1 to maximum resistance. Blow hot air from a hair dryer onto the sensor-diodes for a minute or so, then get the temperature meter near the sensor diodes and adjust P1 slowly towards the minimum resistance position with a digital meter hooked up on pin 7 of IC2.B. Roughly calibrate the temperature to 40 degrees C. At this temperature, the meter will show approximately 12 V.

The circuit will draw about 120 mA from its 12-V supply.

(030183-1)

3.3 V or 5 V Direct from the Mains



Gregor Kleine

The SR03x range of voltage regulator chips from Supertex (www.supertex.com) connects directly to the rectified mains supply and provides a low-current 3.3 V or 5.0 V output without the need for any step-down transformer or inductor.

The circuit requires a full-wave rectified mains voltage input (**waveform a**). A built-in comparator controls a series-pass configured MOSFET. The MOSFET is only switched on whenever the input voltage is below an 18 V threshold. A 220 µF capacitor is used to smooth out fluctuations so that the resultant voltage has a sawtooth waveform (**waveform b**) with a peak value of 18 V. This unregulated voltage is connected to the source input of the chip (pin 7) and an internal voltage regulator produces a regulated output (**waveform c**) of 3.3 V for the type SR036 or 5.0 V for the SR037.

Normally you would expect to see a reservoir capacitor fitted across the output of a full wave rectifier in a power supply circuit but in this case it is important to note that one is **not** fitted. For correct operation it is necessary for the input voltage to fall close to zero during each half wave.

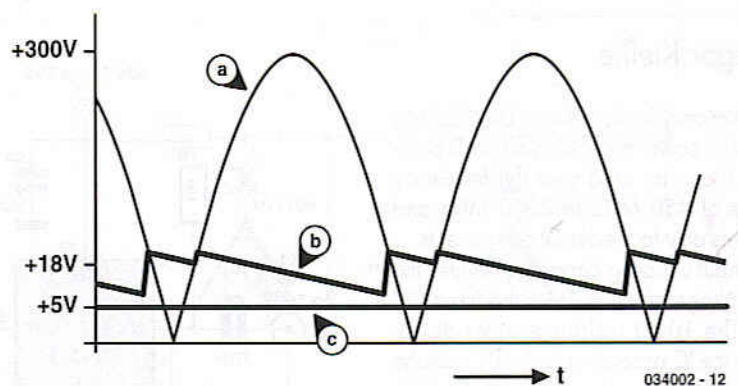
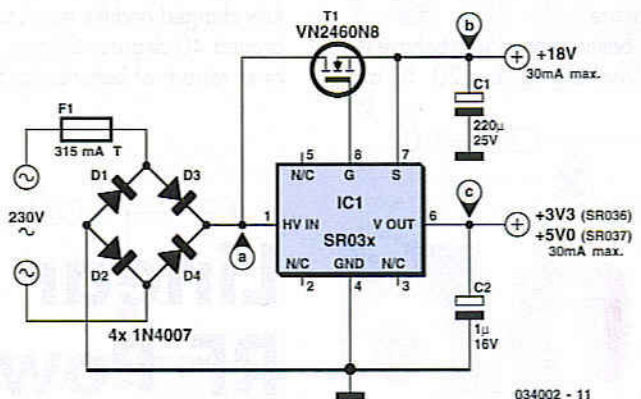

Warning: This circuit must only be used in a fully encapsulated enclosure with no direct connections to any external circuit. It is important to be aware that the circuit is

connected to the mains and the chip has lethal voltages on its pins! All appropriate safety guidelines must be adhered to.

(034002-1)

015

Lifespan of Li-Ion Batteries

Karel Walraven

New technologies can introduce new problems. We haven't really had enough experience in the use of Lithium-Ion batteries to make a precise statement on their lifespan. Stories are floating around of a short lifespan of only a few years when used intensively in notebooks, whereas it should be possible for them to last anywhere between 500 and 1,000 cycles. Should you use the full capacity of the battery 200 days per year, it should in theory have a lifespan of about three years. But even when the battery has gone through only 100 cycles it appears to have lost some capacity. With nickel-cadmium and nickel-hydrate cells it is recommended that they are never fully discharged, nor fully charged. The NiMH battery used by Toyota in the 'Prius' car operates between 40 % and 80 % of capacity and has an 8-year guarantee. If it was used between 0 and 100 % it wouldn't even survive one year of intensive use. Lithium-Ion batteries appear to behave differently. Discharging by 20 % and

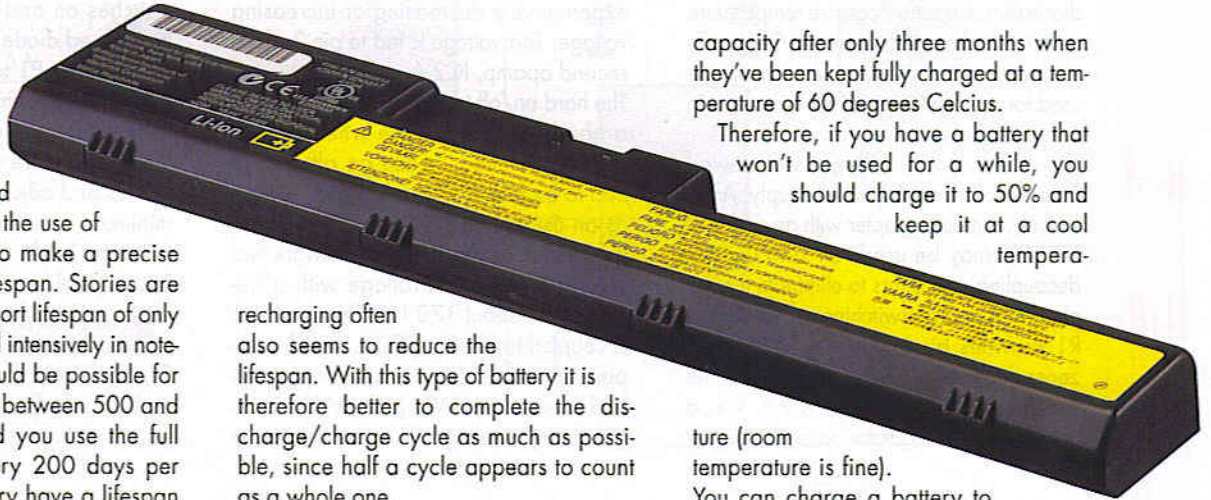

recharging often also seems to reduce the lifespan. With this type of battery it is therefore better to complete the discharge/charge cycle as much as possible, since half a cycle appears to count as a whole one. A second aspect is the oxidation of the electrodes. They begin to deteriorate right from the moment of manufacture and that process is unavoidable. This causes a gradual reduction in the useable capacity. Although this process can't be stopped, it can be slowed down. The key words here are 'low temperature' and 'not fully charged'. It is ironic that this is the exact opposite to the conditions found in a typical notebook: the battery is kept fully charged and the temperature is often around 40 degrees Celcius. There have been reports of batteries losing half their

capacity after only three months when they've been kept fully charged at a temperature of 60 degrees Celcius. Therefore, if you have a battery that won't be used for a while, you should charge it to 50% and keep it at a cool temperature.

(room temperature is fine). You can charge a battery to 50 % of its capacity by reducing the charging voltage to about 3.9 V. In any case, you should check the output voltage of the charger and take away a few tenths of a volt. Accidents can happen when the charging voltage is too high! Another cause of failure is when the battery is deeply discharged due to self-discharge. To avoid damage the battery voltage should never drop below 2 V. At room temperature this means that the battery should be checked once or twice a year, and recharged if necessary.

(049023-1)

016

Linear RF Power Meter

Gregor Kleine

The National Semiconductor LMV225 is a linear RF power meter IC in an SMD package. It can be used over the frequency range of 450 MHz to 2000 MHz and requires only four external components. The input coupling capacitor isolates the DC voltage of the IC from the input signal. The 10-kΩ resistor enables or disables the IC according to the DC voltage present at the input pin. If it is higher than 1.8 V, the detector is enabled and draws a current of around 5–8 mA. If the voltage on pin A1 is less than 0.8 V, the IC enters the shutdown mode and draws a current of only a few microampères. The

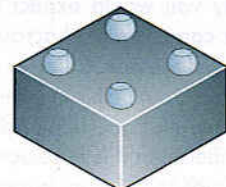
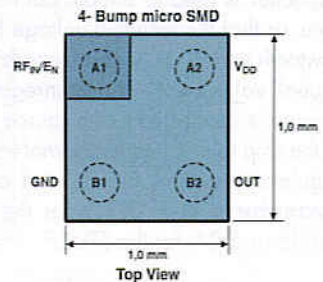
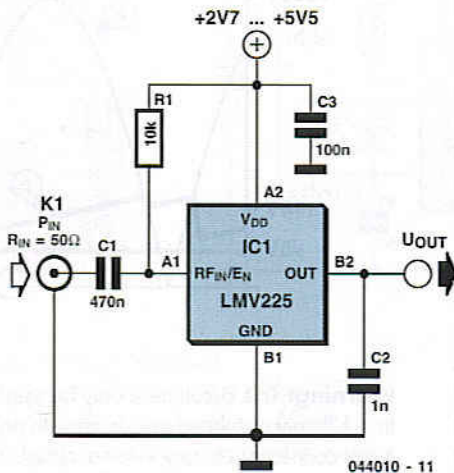

LMV225 can be switched between the active and shutdown states using a logic-level signal if the signal is connected to the signal via the 10-kΩ resistor. The supply voltage, which can lie between +2.7 V und +5.5 V, is filtered by a 100-nF capacitor that diverts residual RF signals to ground. Finally, there is an output capacitor that forms a low-pass filter in combination with the internal circuitry of the LMV225. If this capacitor has a value of 1 nF, the corner frequency of this low-pass filter is approximately 8 kHz. The corner frequency can be calculated using the formula

$$f_c = 1 / (2 \pi C_{OUT} R_o)$$

where R_o is the internal output impedance (19.8 kΩ). The output low-pass filter determines which AM modulation components are passed by the detector.

The output, which has a relatively high impedance, provides an output voltage that is proportional to the signal power,

with a slope of 40 mV/dB. The output is 2.0 V at 9 dBm and 0.4 V at -40 dBm. A level of 0 dBm corresponds to a power of 1 mW in 50 Ω. For a sinusoidal waveform, this is equivalent to an effective voltage of 224 mV. For modulated signals, the relationship between power and voltage is generally different. The table shows several examples of power levels and voltages for sinusoidal signals. The input impedance of the LMV225 detector is around 50 Ω to provide a good match to the characteristic impedance commonly

dBm	mW	U _{eff} (Sinusoid)
-40	0.0001	2.24 mV
-30	0.001	7.07 mV
-20	0.01	22.4 mV
-10	0.1	71 mV
0	1	224 mV
10	10	707 mV

used in RF circuits. The data sheet for the LMV225 shows how the 40-dB measurement range can be shifted to a higher power level using a series input resistor. The LMV225 was originally designed for use in mobile telephones, so it comes in a tiny SMD package with dimensions of only around 1 × 1 mm with four solder bumps (similar to a ball-grid array package). The connections are labelled A1, A2, B1 and B1, like the elements of a matrix. The corner next to A1 is bevelled.

(D44010-1)

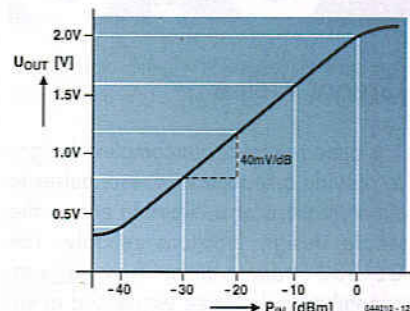

Adjustable Zener Diode

Dieter Bellers

A Zener diode is the simplest known type of voltage limiter (Figure 1). As soon as the voltage exceeds the rated voltage of the Zener diode, a current can flow through the diode to limit the voltage. This is exactly the right answer for many protection circuit applications.

However, if it is necessary to limit a signal to a certain voltage in a control circuit, Zener diodes do not provide an adequate solution. They are only available with fixed values, which are also subject to a tolerance range. What we are looking for is thus an 'adjustable' Zener diode. Such a component would be useful in a heating controller with a preheat temperature limiting, for example, or in a battery charger to provide current limiting.

The answer to our quest is shown in Figure 2. Assume for example that the output voltage must not exceed 6.5 V. The control voltage on the non-inverting input is thus set to 6.5 V. Now assume that 4.2 V is present at the input. The result is that the maximum positive voltage is present at the opamp output, but the diode prevents this from having any effect on the signal.

1

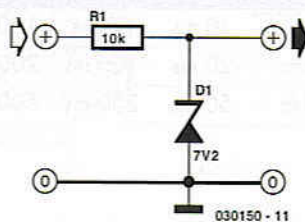

2

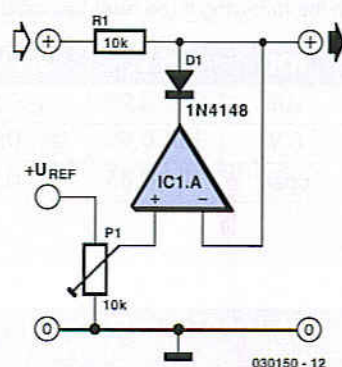

3

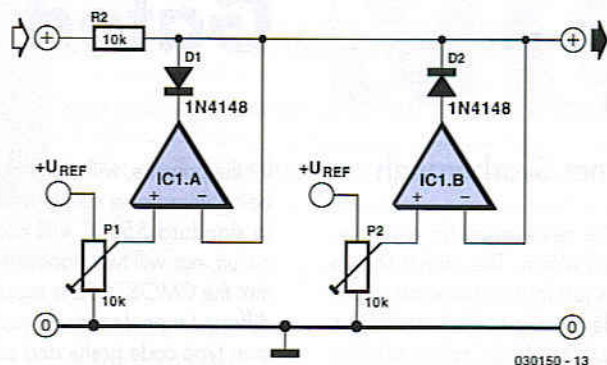

However, if the voltage rises above 6.5 V, the output of the opamp goes negative

and pulls the voltage back down to 6.5 V. The current is limited by R3.

Another example is a situation in which exactly the opposite is required. In this case, the voltage must not drop below a certain value. This can be easily achieved by reversing the polarity of the diode.

Another option is a voltage that is only allowed to vary within a certain voltage window. It must not rise above a certain value, but it also must not drop below another specific value. In the circuit shown

in **Figure 3**, the left-hand opamp provides the upper limit and the right-hand opamp provides the lower limit. Each opamp is wired as a voltage follower.

(030150-1)

018

Gregor Kleine

It is often necessary in complex designs to provide a sequence of reset pulses to different parts of a circuit to ensure the whole design functions reliably. The DS1830 from Maxim (www.maxim-ic.com) provides three sequenced open-drain reset outputs. This chip is designed for 5 V systems but a 3.3 V version (DS1830A) is also available. Both are offered in a range of package outlines including DIP, SO and μ SOP.

Two inputs give the chip some degree of programmability of its characteristics: The TOL input defines the chip's tolerance to power supply fluctuations before a reset sequence is triggered. Jumper JP1 allows the TOL to be connected to U_b (Vcc), ground or left open circuit and will result in the following three reset thresholds:

TOL	5 V	3.3 V
+ U_b	$U_b \cdot 0.95$	$U_b \cdot 0.95$
0 V	$U_b \cdot 0.90$	$U_b \cdot 0.90$
open	$U_b \cdot 0.85$	$U_b \cdot 0.80$

Reset Sequencer

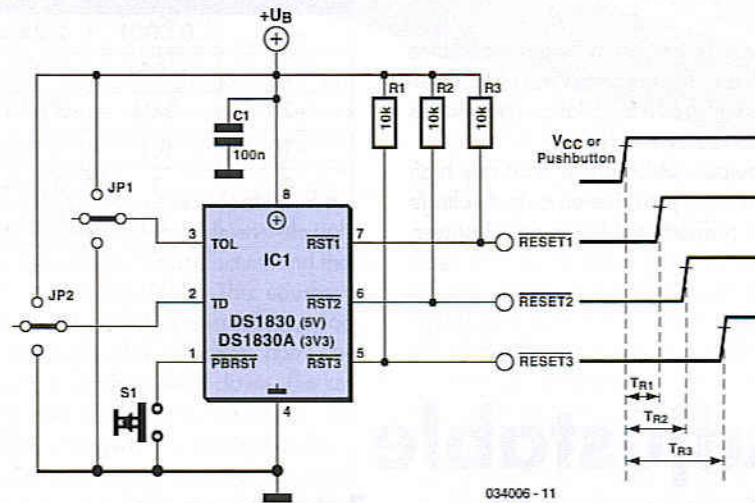

034006-11

The TD input allows the length of the reset signal to be programmed and jumper JP2 gives the following three possibilities:

TD	T_{R1}	T_{R2}	T_{R3}
0 V	10 ms	50 ms	100 ms
open	20 ms	100 ms	200 ms
+ U_b	50 ms	250 ms	500 ms

The $\overline{\text{PBRST}}$ (pushbutton reset) allows a manual reset button to be connected to the chip. This input has a built-in 40 k Ω pull up resistor and can also be driven by a digital output or used to cascade additional devices to provide more sequenced reset signals.

(034006-1)

019

Rev. Thomas Scarborough

Sometimes the need arises for a simple, gated, pulsed alarm. The circuit shown here employs just four components and a piezo sounder and is unlikely to be outdone for simplicity. While it does not offer the most powerful output, it is likely to be adequate for many applications. A dual CMOS timer IC type 7556 is used

for the purpose, with each of its two halves being wired as a simple astable oscillator (a standard 556 IC will not work in this circuit, nor will two standard 555's). Note that the CMOS7556 is supplied by many different manufacturers, each using their own type code prefix and suffix. The relevant Texas Instruments product, for instance, will be marked 'TLC556CN'. The circuit configuration used here is sel-

dom seen, due probably to the inability of this oscillator to be more than lightly loaded without disturbing the timing. However, it is particularly useful for high impedance logic inputs, since it provides a simple means of obtaining a square wave with 1:1 mark-space ratio, which the 'orthodox' configuration does not so easily provide. IC1.A is a slow oscillator which is

enabled when reset pin 4 is taken High, and inhibited when it is taken Low. Output pin 5 of IC1.A pulses audio oscillator IC1.B, which is similarly enabled when reset pin 10 is taken High, and inhibited when it is taken Low.

In order to simplify oscillator IC1.B, piezo sounder X1 doubles as both timing capacitor and sounder. This is possible because a passive piezo sounder typically has a capacitance of a few tens of nanofarads, although this may vary greatly. As the capacitor-sounder charges and discharges, so a tone is emitted. The value of resistor R2 needs to be selected so as to find the resonant frequency of the piezo sounder, and with this its maximum volume. The circuit will operate off any sup-

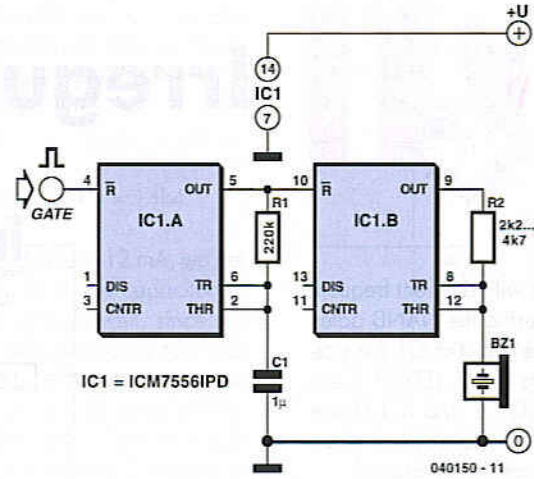

ply voltage between 2 V and 18 V. A satisfactory output will be obtained at rela-

tively high supply voltages, but do not exceed 18 V.

Long-Interval Pulse Generator

Gregor Kleine

A rectangular-wave pulse generator with an extremely long period can be built using only two components: a National Semiconductor LM3710 supervisor IC and a 100-nF capacitor to eliminate noise spikes.

This circuit utilises the watchdog and reset timers in the LM3710. The watchdog timer is reset when an edge appears on the WDI input (pin 4). If WDI is continuously held at ground level, there are not any edges and the watchdog times out. After an interval T_B , it triggers a reset pulse with a duration T_A and is reloaded with its initial value. The cycle then starts all over again. As a result, pulses with a period of $T_A + T_B$ are present at the RESET output (pin 10).

As can be seen from the table, periods ranging up to around 30 seconds can be achieved in this manner. The two intervals T_A and T_B are determined by internal timers in the IC, which is available in various versions with four different ranges for each timer. To obtain the desired period, you must order the appropriate version of the LM3710. The type designation is decoded in the accompanying table. The reset threshold voltage is irrelevant for this particular application of the LM3710. The versions shown in bold face were available at the time of printing. Current infor-

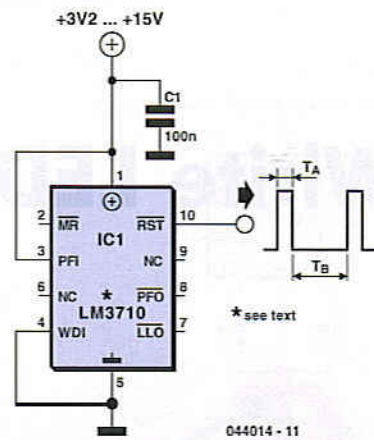

020

LM3710 type designation

LM3710 a b cc ddd

a = output circuit: X = CMOS, Y = open drain
 b = timing (see table)
 cc = package: MM = MSOP, BP = micro SMD
 ddd = reset threshold voltage (e.g., '450' for 4.50 V)

	$T_A = 1,4 \text{ ms}$ (1-2 ms)	$T_A = 28 \text{ ms}$ (20-40 ms)	$T_A = 200 \text{ ms}$ (140-280 ms)	$T_A = 1,6 \text{ s}$ (1.12-2.24 s)
$T_B = 6,2 \text{ ms}$ (4.3-9.3 ms)	LM3710 XExxx	LM3710 XFxxx	LM3710 XGxxx	LM3710 XHxxx
$T_B = 102 \text{ ms}$ (71-153 ms)	LM3710 XJxxx	LM3710 XKxxx	LM3710 XLxxx	LM3710 XMxxx
$T_B = 1,6 \text{ s}$ (1.12-2.4 s)	LM3710 XNxxx	LM3710 XPxxx	LM3710 XQxxx	LM3710 XRxxx
$T_B = 25,6 \text{ s}$ (17.9-38.4 s)	LM3710 XSxxx	LM3710 XTxxx	LM3710 XUxxx	LM3710 XVxxx
T_A = Reset Timeout Period T_B = Watchdog Timeout Period				

mation can be found on the manufacturer's home page (www.national.com). The numbers in brackets indicate the minimum and maximum values of intervals T_A

and T_B for which the LM3710 is tested. The circuit operates with a supply voltage in the range of 3-5 V.

Irregular Flasher

Ludwig Libertin

Two multivibrators with different frequencies can be built using the NAND gates of a 4011 IC. If the output of IC1.B is positive with respect to IC1.C, LED D1 is on. As the levels of IC1.A and IC1.D are exactly opposite, D2 is always on when D1 is off, and the other way around.

The two oscillators have different frequencies, which are determined by the values of R2/C2 and R5/C5 respectively according to the formula

$$f_0 = 1 / (1.4 RC)$$

With the given component values, the frequencies are 2.2 Hz and 7.2 Hz. Low-current LEDs should be used, since the CMOS IC cannot sink or source sufficient current for 'normal' LEDs. The values of series resistors R3 and R6 are suitable for a supply voltage of 12 V, in which case the current consumption of the circuit is around 5 mA. However, in principle the

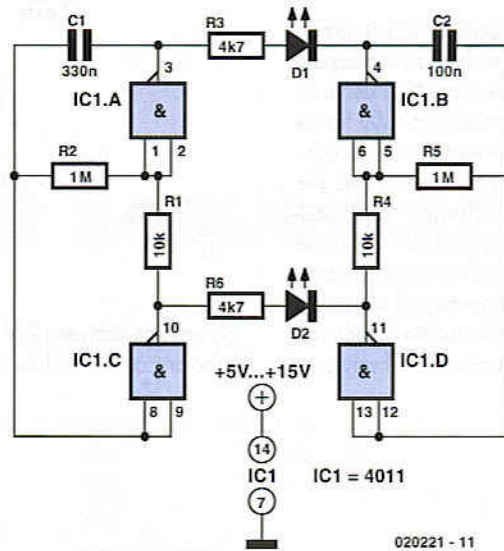

4011 can be operated over a supply voltage range of 5–15 V. Higher currents can be provided by the HC family (supply voltage 3–6 V) or the HCT family (5 V). Inci-

dentally, the part number of the quad gate IC in the HC family is HC7400.

(020221-1)

White LED Lamp



Did it ever occur to you that an array of white LEDs can be used as a small lamp for the living room? If not, read on. LED lamps are available ready-made, look exactly the same as standard halogen lamps and can be fitted in a standard

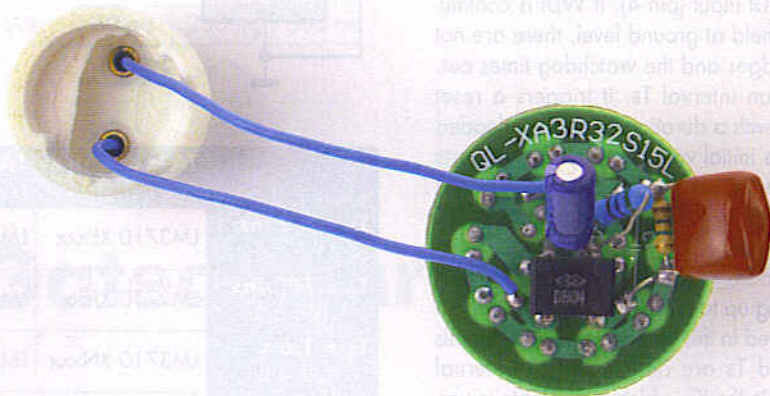

230-V light fitting.

We opened one, and as expected, a capacitor has been used to drop the voltage from 230 V to the voltage suitable for the LEDs. This method is cheaper and smaller compared to using a transformer. The lamp uses only 1 watt and therefore

also gives off less light than, say, a 20 W halogen lamp. The light is also somewhat bluer.

The circuit operates in the following manner: C1 behaves as a voltage dropping 'resistor' and ensures that the current is not too high (about 12 mA). The bridge

rectifier turns the AC voltage into a DC voltage. LEDs can only operate from a DC voltage. They will even fail when the negative voltage is greater than 5 V. The electrolytic capacitor has a double function: it ensures that there is sufficient voltage to light the LEDs when the mains voltage is less than the forward voltage of the LEDs and it takes care of the inrush current peak that occurs when the mains is switched on. This current pulse could otherwise damage the LEDs. Then there is the 560-ohm resistor, it ensures that the current through the LED is more constant and therefore the light output is more uniform. There is a voltage drop of 6.7 V across the 560-Ω resistor, that is, 12 mA flows through the LEDs. This is a safe value. The total voltage drop across the LEDs is therefore 15 LEDs times 3 V or about 45 V. The voltage across the electrolytic capacitor is a little more than 52V.

To understand how C1 functions, we can calculate the impedance (that is, resistance to AC voltage) as follows:

$$1 / (2\pi \cdot f \cdot C), \text{ or:}$$

$$1 / (2 \cdot 3.14 \cdot 50 \cdot 220 \cdot 10^{-9}) = 14 \text{ k}\Omega.$$

When we multiply this with 12 mA, we get a voltage drop across the capacitor of 173 V. This works quite well, since the 173-V capacitor voltage plus the 52-V LED voltage equals 225 V. Close enough to the mains voltage, which is officially 230 V. Moreover, the latter calculation is not very accurate because the mains voltage is in practice not quite sinusoidal. Furthermore, the mains voltage from which 50-V DC has been removed is far from sinusoidal. Finally, if you need lots of white LEDs then it is worth considering buying one of these lamps and smashing the bulb with

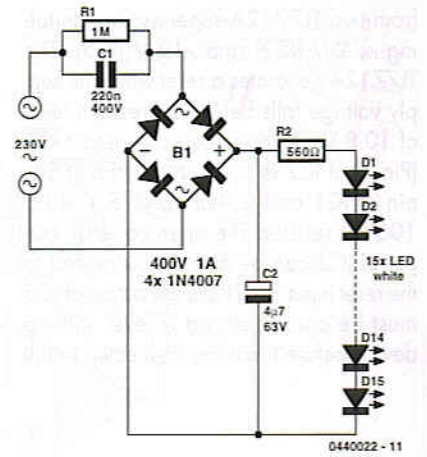

a hammer (with a cloth or bag around the bulb to prevent flying glass!) and salvaging the LEDs from it. This can be much cheaper than buying individual LEDs...

(044022-1)

Reset from Multiple Power Supplies

023

Gregor Kleine

Processor based systems usually require a voltage supervisor chip to produce a clean reset pulse to the processor whenever a 'brown-out' condition of the power supply is detected. More complex designs employing multiple power supplies can be unreliable if some of the supplies are not supervised. The circuit described here monitors all the supply rails in the system (here +12 V, -12 V and +5 V) and provides a reset pulse to the processor whenever it detects any are not within tolerance.

IC1 (TL7705A) generates a processor reset if the 5 V rail falls below 4.55 V. The value of the capacitor fitted to pin 3 defines the reset pulse width t_d according to the formula:

$$t_d = 12 \cdot C_T \cdot 10^3$$

With C_T in μF the value for t_d is given in μs . A capacitor of 100 nF for example, will produce a reset pulse of around 1.2 ms. Pin 6 (RESET) outputs an active-high pulse and Pin 5 (RESET) an active-low pulse. The outputs are open collector types so an external pull-down and pull-up resistor (respectively) is required. The RESIN input (Pin 2) of IC1 is driven

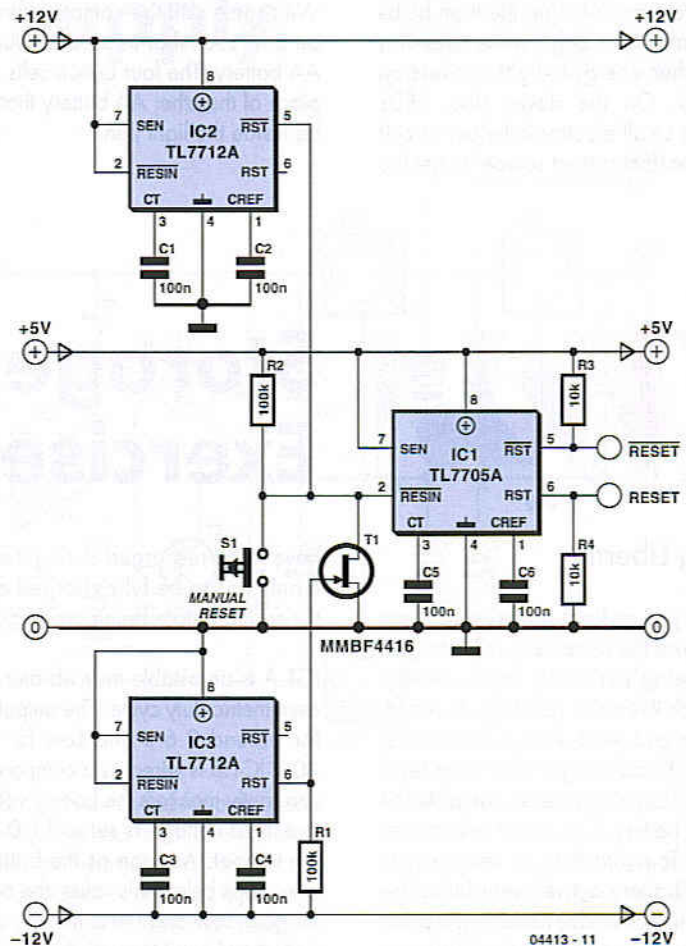

from two TL7712A supervisors monitoring +12 V (IC2) and -12 V (IC3). The TL7712A generates a reset when the supply voltage falls below a threshold level of 10.8 V. The open collector output \overline{RES} (Pin 5) of IC2 is connected to the \overline{RESIN} pin of IC1 and pulled up to 5 V via a 100 k Ω resistor. The open collector output of IC2 can be directly connected to the reset input of IC1 but the output of IC3 must be connected via a level shifting device before it can be connected to the

reset input of IC1 because the voltage level at the output of IC3 goes negative. JFET transistor T1 is used to perform the necessary level shifting. The JFET turns off when the voltage at its gate-source junction is between -2.5 V and -6 V. When IC3 is issuing a reset signal the RES output (pin 6) will go up to ground potential and cause T1 to conduct and trigger a reset of IC1. At all other times the RES output of IC3 will be pulled to a minus voltage via the 100 k Ω resistor which then

causes T1 to stop conducting and release the reset. A manual reset push button can also be connected to \overline{RESIN} of IC1 if required. The SENSE input (Pin 7) of the TL77xx chips is connected to the positive supply rail. The reference input (pin 1) is fitted with a 100 nF capacitor to reduce the effects of fast transients.

The JFET type MMBF4416 is available from Conrad Electronic (www.conrad.de), order no. 14 28 08

(044013-1)

024

LED Light Pen

Myo Min

Physicians and repair engineers often use small light pens for visual examination purposes. Rugged and expensive as these pens may be, their weak point is the bulb, which is a 'serviceable' part. In practice, that nearly always equates to 'expensive' and / or 'impossible to find' when you need one.

LEDs have a much longer life than bulbs and the latest ultra bright white ones also offer higher energy-to-light conversion efficiency. On the down side, LEDs require a small electronic helper circuit called 'constant-current source' to get the

most out of them.

Here, T1 and R1 switch on the LED. R2 acts as a current sensor with T2 shunting off (most of) T1's base bias current when the voltage developed across R2 exceeds about 0.65 V. The constant current through the white LED is calculated from

$$R2 = 0.65 / I_{LED}$$

With some skill the complete circuit can be built such that its size is equal to an AA battery. The four button cells take the place of the other AA battery that used to be inside the light pen.

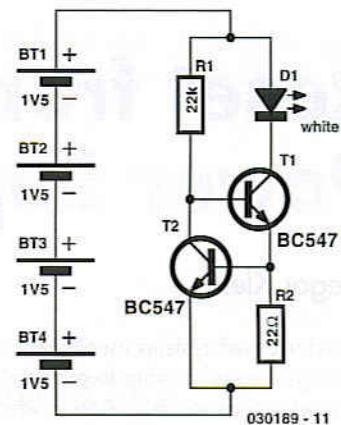

(030189-1)

025

Storage Battery Exerciser

Ludwig Libertin

A motorcycle or boat battery that is not needed over the winter is usually charged before being put away for the winter, after which it remains standing unused for months on end. As a result, it accumulates deposits of lead sludge, which can result in reduced capacity or even complete failure of the battery. If you don't keep active, you rust! To avoid this, it's necessary to keep the battery active even during the winter. This circuit does such a good job of exercising the battery that it doesn't

have to be recharged during the winter. It only has to be fully charged again in the spring before being used again.

IC1.A is an astable multivibrator with an asymmetric duty cycle. The output is High for around 0.6 s and Low for around 40 s. IC1.B is wired as a comparator that constantly monitors the battery voltage. Its threshold voltage is set to 11.0 V using the trimpot. As soon as the battery voltage drops below this value, the comparator goes Low and D6 is cut off, allowing the second astable multivibrator IC1.C to

oscillate at approximately 1.2 Hz. LED D7 then blinks to indicate that the battery must be charged.

As long as the battery voltage is greater than 11 V, IC1.B is High. IC1.A is Low most of the time, and in this state D4 conducts and the inverting input of IC1.D is Low. This means that IC1.D is High most of the time, with T1 cut off. T1 only conducts during the 0.6-s intervals when IC1.A is High. In this state it allows current to pass through the lamp (12 V / 3 W), which forms the actual load for the battery. After

this, darkness prevails again for 40 s. The average current consumption is approximately 5 mA. At this rate, a relatively new

40-Ah battery will take around one year to become fully discharged. However, this can vary depending on the condition of

the battery, and it may be necessary to 'top up' the battery once during the winter.

(034019-1)

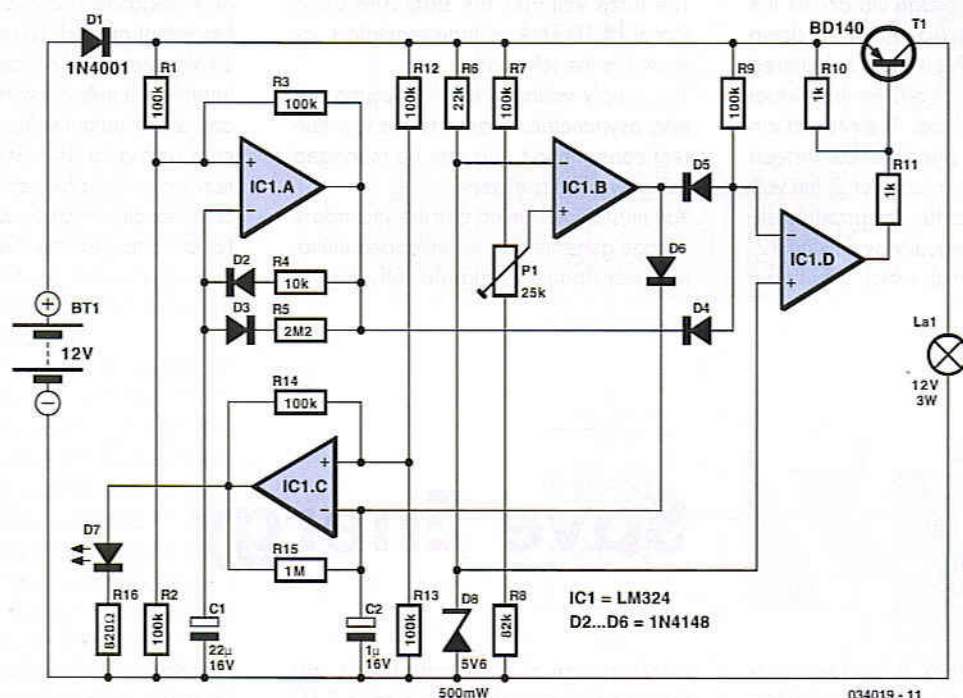

Triple Power Supply

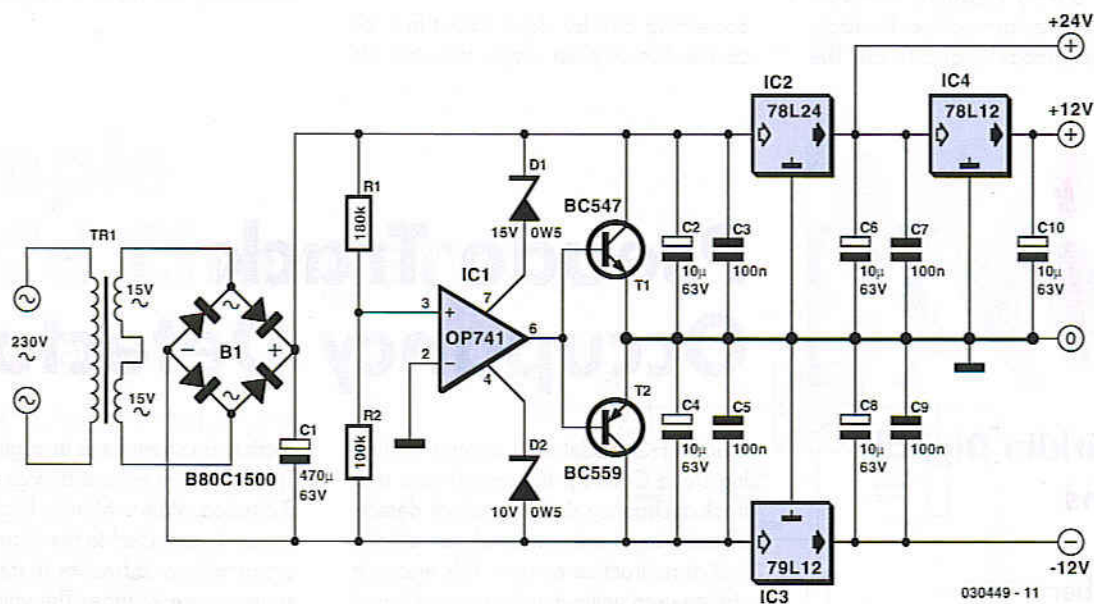

Bernd Schädler

Inexpensive miniature transformers normally provide one or two secondary voltages, which is sufficient for generating a set of positive and negative supply volt-

ages, such as are needed for operational amplifier circuits. But what can you do if you need an additional voltage that is higher than either of the supply voltages (such as a tuning voltage for a receiver)? This circuit shows a simple solution to this

problem, and it certainly can be extended to suit other applications. Using a 2x15-V transformer, it generates positive 24-V and 12-V supply voltages and a negative 12-V supply voltage. The little trick for generating the +24-V

output consists of using IC1 to create a virtual ground. This is based on a well-known circuit with a voltage divider formed by two equal-valued resistors, which divide the voltage U_b across the rectifier from approximately 40 V down to 20 V. This $U_b/2$ potential is buffered by an opamp, which allows this virtual ground to drive a load. The present circuit uses the same principle, but instead of being divided by a factor of 2, the voltage across the rectifier (approximately 40 V) is divided unequally by R1 and R2. The resulting potential, which is buffered

by the opamp and the subsequent transistor output stage, lies approximately 15 V above the lower potential, and thus around 25 V below the upper potential. The three voltages are stabilised using standard 100-mA voltage regulators, as shown in the schematic.

The supply voltages for the opamp are also asymmetric. Thanks to the low current consumption, this can be managed using two Zener diodes.

You must bear in mind that the secondary voltage generated by an unloaded miniature transformer is significantly higher

than its rated secondary voltage. The following results were obtained in a test circuit using a 1.6-VA transformer with two 15-V secondary windings: the positive and negative 12-V outputs could be loaded at around 10 mA each, and the 24-V output could be loaded with approximately 20 mA, all without any drop in any of the output voltages. For small circuits such as a 0(4)-20-mA instrumentation loop, this is fully adequate. For more complex circuits or switched loads, additional compensation may be necessary.

(030449-1)

027

Save Energy

Despite our best efforts, a lot of energy is still wasted imperceptibly. We insulate our homes, install high efficiency boilers and buy low energy light bulbs. But it doesn't end there as far as electrical consumption is concerned. Many other items in the home consume electrical power, but here we concentrate on mains adapters (also called 'wall cubes' or 'battery eliminators'). Take a good look around the house to see how many you have, and you could soon find about ten of them: phone charger(s), battery chargers, mini-vac, telephone, answering machine, the radio in the kitchen, modem, and so on. The

disadvantage of these adapters is that they easily consume from 1 to 2.5 W under no load, without you getting anything in return (apart from some heat, of course). When five mains adapters are in use, each consuming 2 W, they'll take one kilowatt-hour every 100 hours, at a cost of 7 p. And 100 hours amounts to only 4 days! In a year, this is 87.6 times as much, or a bit over £6 per year. And if ten adapters are in use this amounts to over £12.

Something can be done about this, of course. The simplest way is to switch off

all adapters when they are not in use. Most of you do this already, surely. There are probably a few adapters that have to remain switched on at all times though. There is an alternative for these as well: take a look at those modern switched-mode adapters! They no longer have a bulky transformer, just a switched-mode supply. They are (unfortunately) a bit more expensive, but tend to be smaller and give a better regulated output voltage. The quiescent power consumption of these adapters really is very small.

(044028-1)

028

Pseudo Track Occupancy Detector

for Märklin Digital Systems

Nils Körber

Track occupancy detectors are needed for hidden yards and other sections of track that are hard to see, but they are also necessary for block operation. The circuit described here uses an LED to indicate track occupancy for digitally controlled

Märklin HO model train systems (including Delta Control). In contrast to a real track occupancy detector, which detects all vehicles, it only responds to vehicles that draw traction current. This means it can be used without making complicated modifications to the rolling stock and track, since it is only necessary to gap the third rail. This circuit is thus especially suitable for retrofitting to existing installations, and it is equally well suited to M, K and C tracks. The basic idea of the circuit is simple. If a locomotive enters the monitored track

section, a current flows through the motor. This current is sensed and generates an indication. With a Märklin Digital system, power is provided to the locomotive via a controller or a booster in the form of a square-wave voltage. The voltage levels on the rails are approximately -15 V and +15 V. Digital control information is transferred by a continuous sequence of alternating plus and minus levels. This means that the detector circuit must be able to respond to AC signals.

In **Figure 1**, the monitored track section

on the left is connected to the ground terminal '0' via the rails. The third rail, which conducts the traction current to the locomotive, is isolated from the rest of the system (special third-rail insulators are available for this purpose), and it is connected to the 'B' terminal of the controller or booster via the detector circuit. If a locomotive travels over the monitored track section, the positive component of the drive current flows through diodes D1 and D2, while the negative component flows through D3. With a motor current of approximately 250 mA, the voltage drop across a single diode (1N4001 types are used here) is a good 1 V.

The voltage drop across the two diodes connected in series (D1 and D2) is sufficient to illuminate LED1. Although the locomotive will travel somewhat slower due to the voltage drop, this will not cause any problems. A second detector can be obtained by connecting an additional diode to the circuit as shown in **Figure 2**. This causes a second LED to illuminate for negative drive current.

Due to the pulse trains and fluctuations in the traction current, the LED illumination is not constant, but instead flickers more or less strongly. Other traction-power loads, such as coach lighting or taillights, will also generate an 'occupied' indication. In such cases, the LED will remain illuminated even if the locomotive is standing still with no current flowing through the motor. Sometimes the quiescent current through a decoder is sufficient to cause the LED to illuminate (a little bit)

1

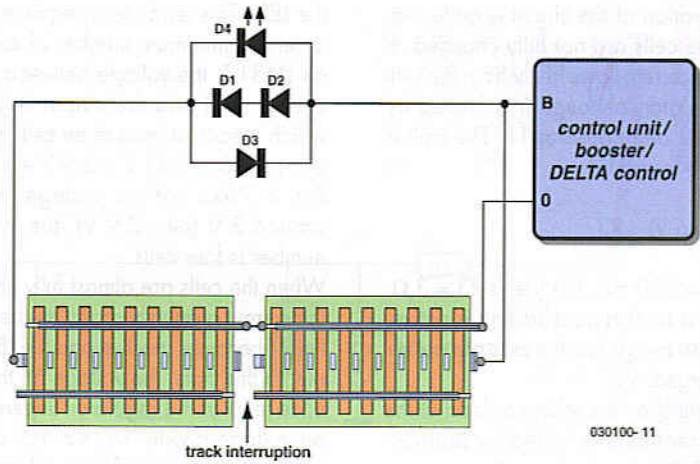

2

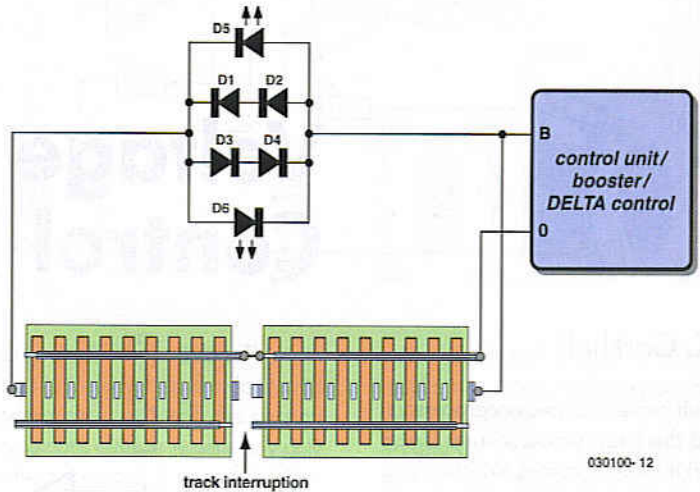

even if the locomotive is standing still. Another possibility is to use an optocoupler instead of an LED. This would allow

the circuit to be connected to an s88 detection module.

(030100-1)

Simple NiCd Charger

Wolfgang Schmidt

A simple NiCd charger can be built using 'junk box' components and an inexpensive LM317 or 78xx voltage regulator. Using a current limiter composed of R3 and a transistor, it can charge as many cells as desired until a 'fully charged' voltage determined by the voltage regulator is reached, and it indicates whether it is charging or has reached the fully charged state. If the storage capacitor (C1) is omitted, pulsed charging takes place. In this mode, a higher charging current can be used, with all of the control characteristics remaining the same.

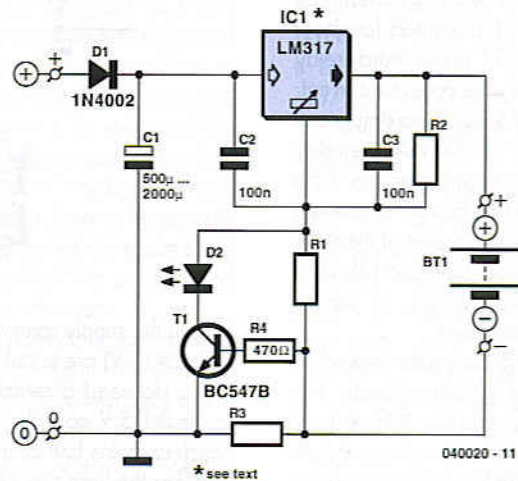

The operation of the circuit is quite simple. If the cells are not fully charged, a charging current flows freely from the voltage regulator, although it is limited by resistor R3 and transistor T1. The limit is set by the formula

$$I_{max} = (0.6 \text{ V}) \div R3$$

For $I_{max} = 200 \text{ mA}$, this yields $R3 = 3 \Omega$. The LED is on if current limiting is active, which also means that the cells are not yet fully charged.

The potential on the reference lead of the voltage regulator is raised by approximately 2.9 V due to the voltage across

the LED. This leads to a requirement for a certain minimum number of cells. For an LM317, the voltage between the reference lead and the output is 1.25 V, which means at least three cells must be charged ($3 \times 1.45 \text{ V} > 2.9 \text{ V} + 1.25 \text{ V}$). For a 78xx with a voltage drop of around 3 V (plus 2.9 V), the minimum number is four cells.

When the cells are almost fully charged, the current gradually drops, so the current limiter becomes inactive and the LED goes out. In this state, the voltage on the reference lead of the regulator depends only on voltage divider R1/R2. For a 7805 regulator, the value of R2 is selected such

that the current through it is 6 mA. Together with the current through the regulator (around 4 mA), this yields a current of around 10 mA through R1. If the voltage across R1 is 4 V ($9 \text{ V} - 5 \text{ V}$), this yields a value of 390 Ω . The end-of-charge voltage can thus be set to approximately 8.9 V. As the current through the regulator depends on the device manufacturer and the load, the value of R1 must be adjusted as necessary. The value of the storage capacitor must be matched to the selected charging current. As already mentioned, it can also be omitted for pulse charging.

(040020-1)

030

Voltage Levels Control Relays

Raj. K. Gorkhali

This circuit proves that microprocessors, PCs and the latest ultra-accurate DACs are overkill when it comes to controlling four relays in sequence in response to a rising control voltage in the range 2.4 V – 12 V. By using equal resistors in ladder network R1-R5, equal intervals are created between the voltages that switch on the relays in sequence. Each resistor drops 1/5th of the supply voltage or 2.4 V in this case, so we get +2.4 V = Re1, +4.8 V = Re2, +7.2 V = Re3, +9.6 V = Re4. Obviously, these switching levels vary along with the supply voltage, hence the need to employ a stabilised power supply.

Looking at the lowest level switching stage, when the control voltage exceeds 2.4 V, IC1 will flip its output to (nearly) the supply level. The resulting current sent into the base of T1 is limited to about 1 mA by R6. With T1 driven hard, relay Re1 is energised by the collector current. Because the BC548 has a maximum collector current spec of 100 mA, the relay coil resistance must not be smaller than 120 ohms. Nearly all current consumed by the circuit goes on account of the relay coils, so depending on your relays a pretty hefty power supply of up to 500 mA may be required.

When dimensioning the ladder network to create the desired switching levels, it is good to remember that the 741 will not operate very well with input voltages below 1.5 V or above 10.5 V, while voltage levels

outside the supply range (i.e., negative or above +12 V) are out of the question. If you do need a switching level in the range 0-1.5 V, consider using an LM324, which contains four opamps in one package. For the high side of the range (10.5

to 12 V), a TL084 or a 'rail-to-rail' opamp like the TS924 is required. However, the TS924 cannot be used with supply voltages above 12 V.

(030191-1)

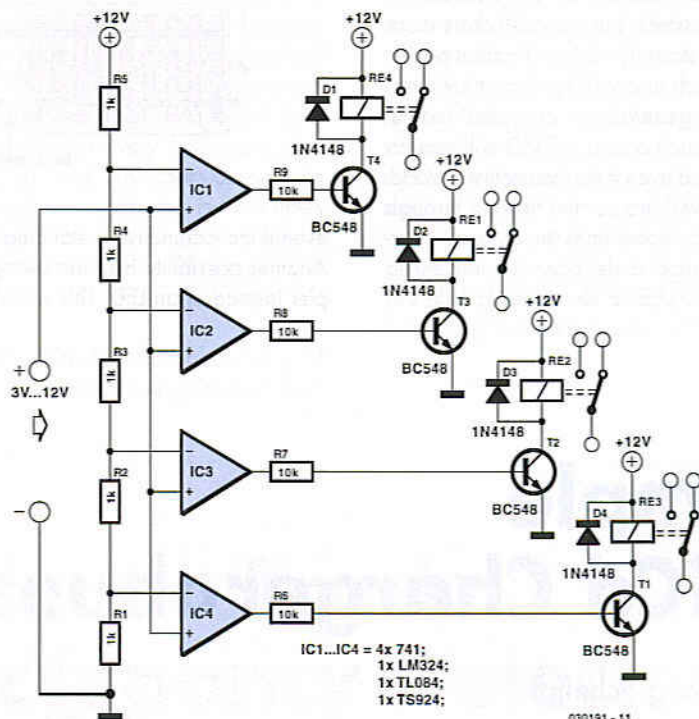

IC1...IC4 = 4x 741;
1x LM324;
1x TL084;
1x TS924;

030191 - 11

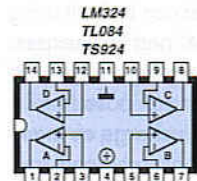
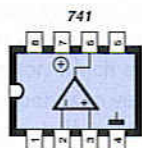

Luxury Car Interior Light

03

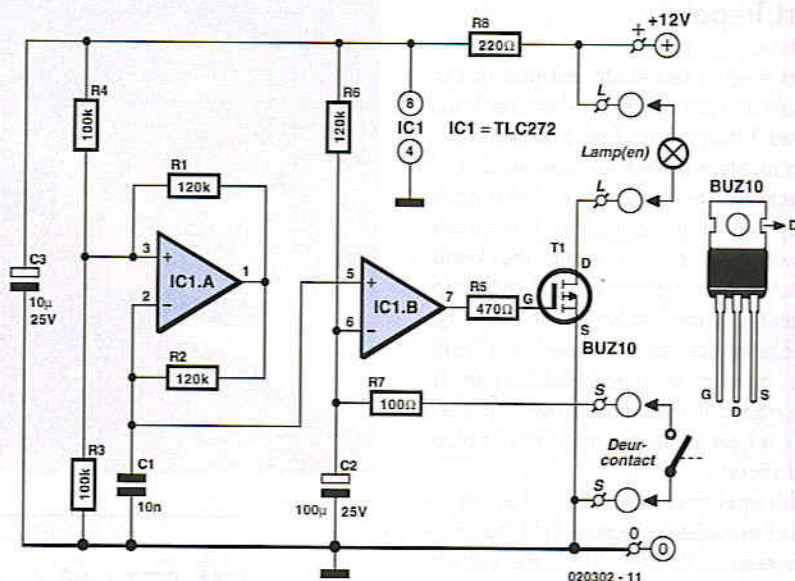
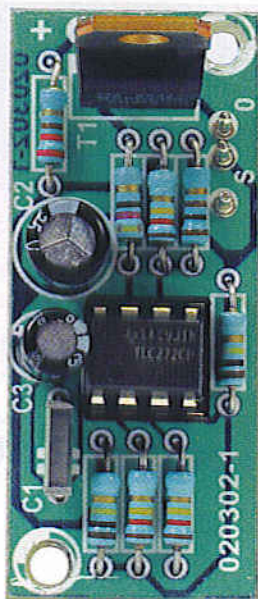

Cuno Walters

This circuit belongs to the 'car modding' category. This is similar to the popular case modding in the computer world and has found its way into a substantial proportion of cars. The modifications vary from light effects to complete movie playback systems. This circuit is much more modest, but certainly still worth the effort. It provides a

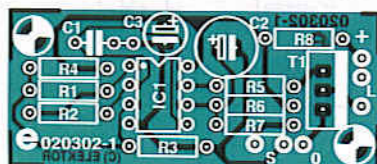

Components list

Resistors:

R1, R2, R6 = 120 kΩ
R3, R4 = 100 kΩ
R5 = 470 Ω
R7 = 100 Ω
R8 = 220 Ω

Capacitors:

C1 = 10 nF
C2 = 100 μF 25V
C3 = 10 μF 25V

Semiconductors:

T1 = BUZ10
IC1 = TLC272CP

Miscellaneous:

PCB available from ThePCBShop

high quality interior light delay. This is a feature that is included as standard with most modern cars, although the version with an automatic dimmer is generally only found in the more expensive models. With this circuit it is possible to upgrade second hand and mid-range models with an interior light delay that slowly dims after the door has been closed.

The dimming of the light is implemented by means of pulse-width modulation. This requires a triangle wave oscillator and a comparator. Two opamps are generally required to generate a good triangle wave, but because the waveform doesn't have to be accurate, we can make do with a single opamp. This results in the circuit around IC1.A, a relaxation oscillator supplying a square wave output. The voltage at the inverting input has more of a triangular shape. This signal can be used as long as we do not put too much of a load on it. The high impedance input of IC1.B certainly won't cause problems in this respect. This opamp is used as a comparator and compares the voltage of the triangular wave with that across the door switch. When the door is open, the switch closes and creates a short to the chassis of the car. The output of the opamp will then be high, causing T1 to conduct and the interior light will turn on.

When the door is closed the light will continue to burn at full strength until the voltage across C2 reaches the lower side of the triangle wave (about 5 V). The comparator will now switch its output at the same rate of the triangle wave (about 500 Hz),

with a slowly reducing pulse width, which results in a slowly reducing brightness of the interior light.

R8 and C3 protect the circuit from voltage spikes that may be induced by the fast switching of the light.

The delay and dimming time can be adjusted with R6 and C2. Smaller values result in shorter times. You can vary the dimming time on its own by adjusting R1, as this changes the amplitude of the triangle wave across C1. R7 limits the discharge current of C2; if this were too big, it would considerably reduce the lifespan of the capacitor.

There is no need to worry about reducing the life of the car battery. The circuit consumes just 350 μA when the lamp is off and a TLC272 is used for the dual opamp. A TL082 will take about 1 mA. These values won't discharge a normal car battery very quickly; the self-discharge is probably many times higher.

It is also possible to use an LM358, TL072 or TL062 for IC1. R8 then needs to have a value between 47 Ω and 100 Ω.

Since T1 is always either fully on or fully off, hardly any heat is generated. At a current of 2 A the voltage drop across the transistor is about 100 mV, giving rise to a dissipation of 200 mW. This is such a small amount that no heatsink is required. The whole circuit can therefore remain very compact and should be easily fitted in the car, behind the fabric of the roof for example.

(020302-1)

Whistling Kettle

Bart Trepak

Most electric kettles do not produce a whistle and just switch off when they have boiled. Fitting a box of electronics directly onto an electric kettle (or even inside!) to detect when the kettle has boiled is obviously out of the question. The circuit shown here detects when the kettle switches off, which virtually all kettles do when the water has boiled. In this way, the electronics can be housed in a separate box so that no modification is required to the kettle. The box is preferably a type incorporating a mains plug and socket.

In this application, the current flowing in coil L1 provides a magnetic field that actuates reed switch S1. Since the current drawn by the kettle element is relatively large (typically 6 to 8 amps), the coil may consist of a few turns of wire around the reed switch. The reed switch is so fast it will actually follow the AC current flow through L1 and produce a 100-Hz buzz. The switching circuit driven by the reed switch must, therefore, disregard these short periods when the contacts open, and respond only when they remain open for a relatively long period when the kettle has switched off.

The circuit is based on a simple voltage controlled oscillator formed around T2 and T3. Its operation is best understood by considering the circuit with junction R4/R5 at 0 V and C4 discharged. T2 will receive base current through R5 and turn on, causing T3 to turn on as well. The falling collector voltage of T3 is transmitted to the base of T2 by C4 causing this transistor to conduct harder. Since the action is regenerative, both transistors will turn on quickly and conduct heavily. C4 will therefore charge quickly through T2's base-emitter junction and T3. Once the voltage across C4 exceeds about 8.5 V (leaving less than 0.5 V across T2's b-e junction), T2 will begin to turn off. This action is also regenerative so that soon both transistors are switched off and the collector voltage of T3 rises rapidly to +9 V. With C4 still charged to 8.5 V, the base of T2 will rise to about 17.5 V holding T2 (and thus T3) off. C4 will now discharge relatively slowly via R5 until T2 again begins to conduct whereupon the cycle will repeat. The voltage at the collector of T3 will therefore be a series of short

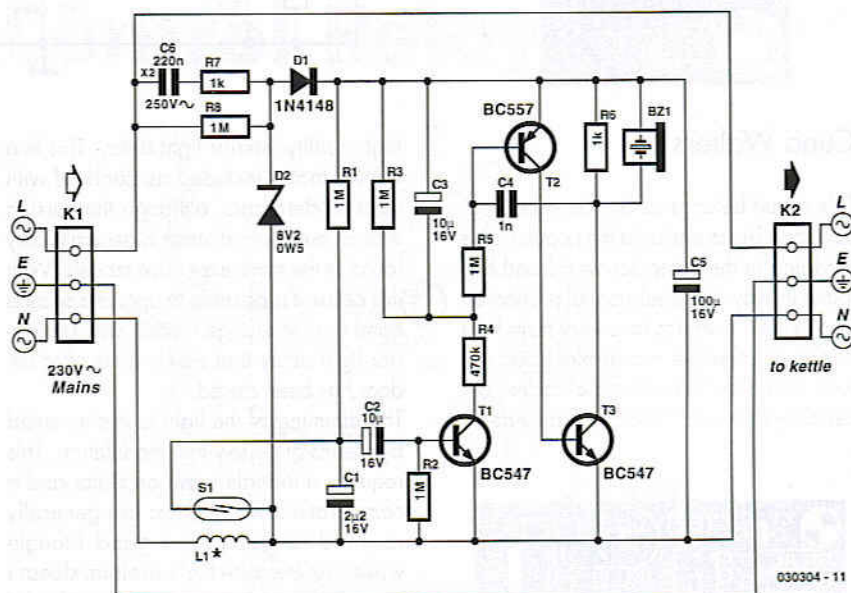

negative going pulses whose basic frequency will depend on the value of C4 and R5. The pulses will be reproduced in the piezo sounder as a tone.

The oscillation frequency of the regenerative circuit is heavily dependent on the voltage at junction R4/R5. As this voltage increases, the frequency will fall until a point is reached when the oscillation stops altogether. With this in mind, the operation of the circuit around T1 can be considered. In the standby condition, when the kettle is off, S1 will be open so that C1 and C2 will be discharged and T1 will remain off so that the circuit will draw no current. When the kettle is switched on, S1 is closed, causing C1 and C2 to be discharged and T1 will remain off. C3 will remain discharged so that T2 and T3 will be off and only a small current will be drawn by R1. Although S1 will open peri-

odically (at 100 Hz), the time constant of R1/C1 is such that C1 will have essentially no voltage on it as the S1 contacts continue to close.

When the kettle switches off, S1 will be permanently open and C1/C2 will begin to charge via R1, causing T1 to switch on. C3 will then begin to charge via R4 and the falling voltage at junction R4/R5 will cause T2/T3 to start oscillating with a rising frequency. However, once T1 has switched off, C3 will no longer be charged via R4 and will begin to discharge via R3 and R5 causing the voltage at R4/R5 to rise again. The result is a falling frequency until the oscillator switches off, returning the circuit to its original condition. As well as reducing the current drawn by the circuit to zero, this mimics the action of a conventional whistling kettle, where the frequency rises

as more steam is produced and then falls when it is taken off the boil.

The circuit is powered directly by the mains using a 'lossless' capacitive mains dropper, C6, and zener diode, D2, to provide a nominal 8 V dc supply for the circuit.

A 1-inch reed switch used in the prototype required about 9 turns of wire to operate with a 2-kW kettle element. Larger switches or lower current may require more turns. In general, the more turns you

can fit on the reed switch, the better, but do remember that the wire has to be thick enough to carry the current.

It is strongly recommended to test the circuit using a 9-volt battery instead of the mains-derived supply voltage shown in the circuit diagram. A magnet may be used to operate S1 and so simulate the switching of the kettle.

Warning. This circuit is connected directly to the 230-V mains and none of

the components must be touched when the circuit is in use. The circuit must be housed in an approved ABS case and carry the earth connection to the load as indicated. Connections and solder joints to components with a voltage greater than 200 volts across them (ac or dc) must have an insulating clearance of at least 6 mm. An X2 class capacitor **must** be used in position C6.

(030004-1)

Programmable-Gain Amplifier

033

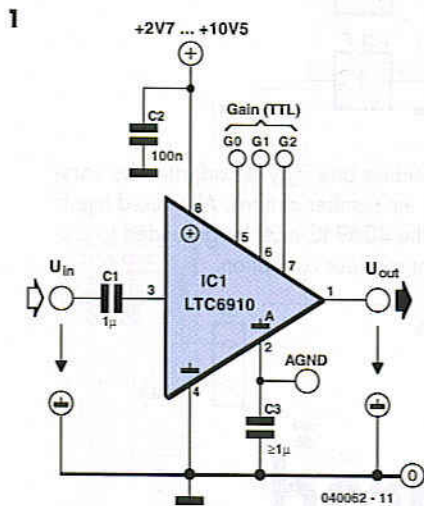

Gregor Kleine

The gain of an operational amplifier is usually set using two external resistors. If you wish to have adjustable gain, you can use a digitally controlled multiplexer to select several different gain-setting resistors.

Such an arrangement using several ICs can now be replaced by the Linear Technology LTC 6910 single amplifier or LTC 6911 dual amplifier. These ICs incorporate all of the gain-setting components and can be programmed to eight different gain settings using three digital control inputs. The amplifier is always configured in the inverting mode and features rail-to-rail input and output. The input and output can be driven to within a few tens of millivolts of the supply voltages. At a gain of 100, the bandwidth still extends to approximately 100 kHz.

With a unipolar supply, the supply voltage for the LTC 6910/6911 can range from +2.7 V to +10.5 V. With a bipolar supply, the IC can be operated at ±1.4 V to ±5.25 V. There are several different versions of the IC, which are identified by

the suffix -1, -2 or -3. The gains for the various combinations of the digital control signals are shown in the table.

It should be noted that due to the internal arrangement of the resistors, the input resistance of the amplifier can range from 1 kΩ to 10 kΩ, depending on the gain setting. This means that a low-impedance signal source must be used to avoid affecting the configured gain setting.

The AGND pin (pin 2) is the non-inverting input of the internal opamp. It is connected to an internal voltage divider consisting of two 5-kΩ resistors between V+ and V-. When a single supply voltage is used, a capacitor with a value of at least 1 µF must be connected to this pin (**Figure 1**). With a bipolar supply, AGND can be connected directly to signal ground (**Figure 2**). Note also that with a unipolar supply, a coupling capacitor is required at the input, and possibly also at the output, since the input and output are internally biased to half the supply voltage. These coupling capacitors will determine the lower corner frequency of the amplifier.

(040062-1)

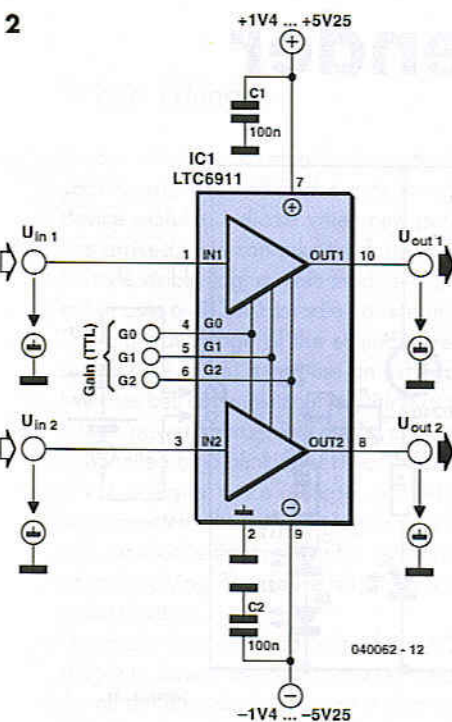

G2	G1	G0	LTC6910-1	LTC6911-1	LTC6911-2	LTC6910-3
0	0	0	0	0	0	0
0	0	1	-1	-1	-1	-1
0	1	0	-2	-2	-2	-2
0	1	1	-5	-5	-4	-3
1	0	0	-10	-10	-8	-4
1	0	1	-20	-20	-16	-5
1	1	0	-50	-50	-32	-6
1	1	1	-100	-100		

SSB Add-On for AM Receivers

D. Prabakaran

Given favourable radio wave propagation, the shortwave and radio amateur band are chock-a-block with SSB (single-sideband) transmissions, which no matter what language they're in, will fail to produce intelligible speech on an AM radio. SSB is transmitted without a carrier wave. To demodulate an SSB signal (i.e. turn it into intelligible speech) it is necessary to use a locally generated carrier at the receiver side. As most inexpensive SW/MW/LW portable radios (and quite a few more expensive general coverage receivers) still use plain old 455 kHz for the intermediate frequency (IF), adding SSB amounts to no more than allowing the radio's IF to pick up a reasonably strong 455-kHz signal and let the existing AM demodulator do the work. The system is called BFO for 'beat frequency oscillator'.

The heart of the circuit is a 455-kHz ceramic resonator or crystal, X1. The resonator is used in a CMOS oscillator circuit supplying an RF output level of 5 V_{pp}.

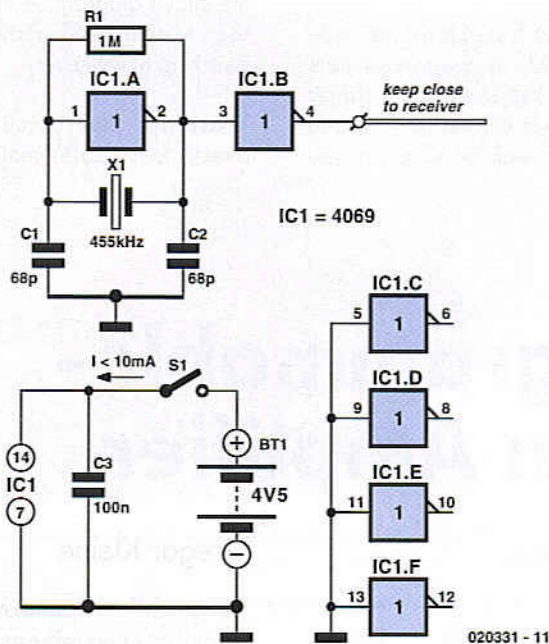

which is radiated from a length of insulated hookup wire wrapped several times around the receiver. The degree of inductive coupling needed to obtain a good beat note will depend on the IF amplifier

shielding and may be adjusted by varying the number of turns. All unused inputs of the 4069 IC must be grounded to prevent spurious oscillation.

(020331-1)

Simple Infrared Control Extender

Raj. K. Gorkhali

Lots of consumer electronic equipment like TV sets, VCRs, CD and DVD players employs infrared remote control. In some cases, it is desirable to extend the range of the available control and this circuit fits the bill, receiving the IR signal from your remote control and re-transmitting it, for example, around a corner into another room.

Photodiode D4 is connected to the inverting input of a 741 opamp through resistor R2 and capacitor C1. Since the BPW41 photodiode (from Vishay/Telefunken) needs to be reverse-biased to turn light energy into a corresponding voltage, it is also connected to the positive supply rail via R1. The non-inverting input of the '741 is held at half the supply voltage by

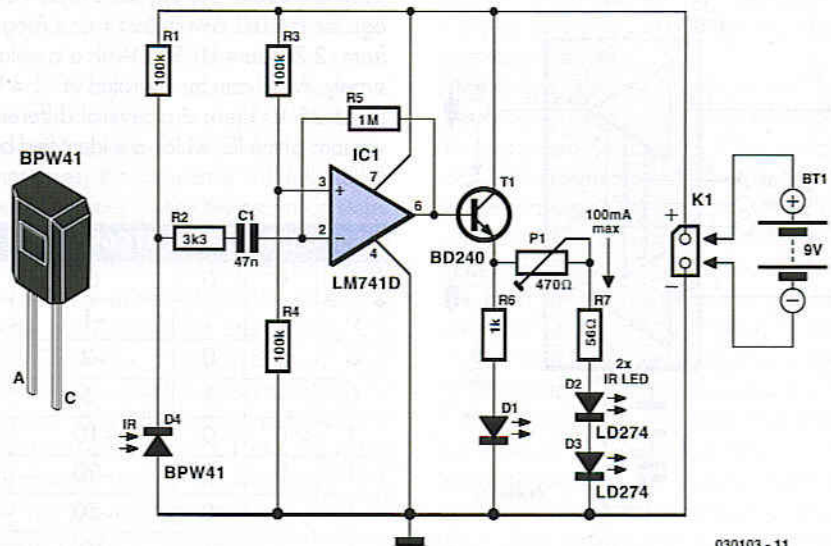

030103 - 11

means of equal resistors R3 and R4. The opamp is followed by a BD240 afterburner transistor capable of supplying quite high current pulses through IR LEDs D2 and D3. However, the pulsed current through the LD274s should not exceed 100 mA or so, hence a fixed resistor is used in series with preset P1. D1 is an

ordinary visible-light LED that flashes when an IR signal is received from the remote. With regard to the setting of P1, do not make the IRED current higher than necessary to reliably reach the final destination of the IR signal. Also, the currents mentioned above are peak levels — due to the small duty factor of the IR pulses,

the average current drawn from the battery will be much smaller.

The directivity of the IR LEDs — and consequently the range of the control extender — may be increased by fitting the devices with reflective caps.

(030103-1)

You Have Mail!

036

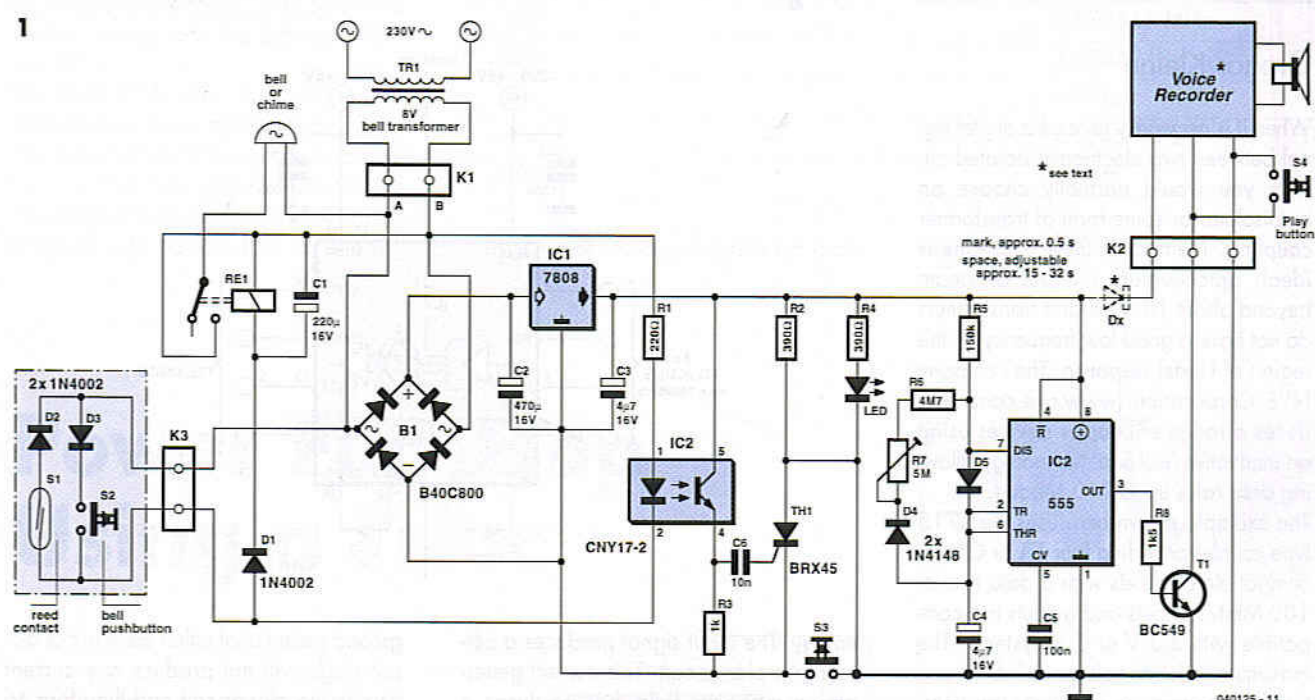

Robert Edlinger

If your letterbox is some distance from your house, you will find a monitoring device useful to indicate when new post has arrived. This can take the form of a US-style visible flag; a more modern alternative uses a 433 MHz radio transceiver. The big advantage of the solution presented here is that it can use an existing two-core bell cable, without requiring any further power source. The arrival of post is signalled by a blinking LED; for added effect, a digital voice recorder can also be connected which will, at regular intervals, announce the fact that the letterbox needs emptying. The device is silenced by a reset button.

The circuit uses one half-cycle of the AC supply to power the bell or buzzer, and the other half-cycle for the post indicator. Suitably-oriented diodes in the device and

in the letterbox ensure that the two signals are independent of one another (**Figure 1**). The bell current flows from K1.A through D3, bell-push S2, D1 and the relay back to K1.B. C1 provides adequate smoothing of the current pulses to ensure that the relay armature does not vibrate. The bell is operated by the normally-open relay contact. If the bell is actually a low-current piezo buzzer, then it can be connected directly and the relay dispensed with.

During the half-cycle for the letterbox monitor current flows from connection K1.B on the bell transformer through current-limiting resistor R1, the LED in the optocoupler, reed contact S1 (a microswitch can also be used) and D2 and finally back to K1. If the reed contacts are closed, the LED in the optocoupler will light and switch on the phototransistor. A positive voltage will then appear across R3 which will turn the thyris-

tor on via C6. The red LED will indicate that post has arrived. Pressing S3 shorts out the thyristor, reducing the current through it below the holding value.

A small extra circuit can be added to provide continuous letterbox monitoring. This takes the form of a voice recorder whose 'play' button is operated by transistor T1. T1 in turn is driven by a 555 timer IC. In the usual 555 timer circuit, where the device is configured as an astable multivibrator, the mark-space ratio cannot be set with complete freedom. Here two diodes provide separate charge and discharge paths for capacitor C4. When capacitor C4 is charging, D5 conducts and D4 blocks: the charge rate is determined by R5. When discharging, D4 conducts and R6 and the potentiometer determine the rate. The values shown give a pulse length of approximately 0.5 s with a delay of between 15 s and 32 s. The

short pulse is sufficient to trigger the voice recorder module via transistor T1 connected across its 'play' button.

The voice recorder module (e.g. Conrad order code 115266) is designed to run from a 6 V supply. The maximum recording time is 20 s and the current consumption is 20 mA when recording and between 40 mA and 60 mA when play-

ing back. Since our supply is at 8 V, the excess voltage must be dropped using between 1 and 3 series-connected 1N4148 diodes (shown as D_x in the circuit diagram). The final voltage should be checked using a multimeter. Alternatively, a 7806 can be used without suffering a significant loss in volume.

If it is desired to use a piezo buzzer to

provide an acoustic signal, the pulse length should be increased to at least 2 s. In this case, R5 should be increased to 560 k Ω or 680 k Ω : the pulse length, t_{on} , is $0.7 \cdot R5 \cdot C4$, and the interval between pulses, t_{off} , is $0.7 \cdot (R6 + R7) \cdot C4$. Suitable buzzers are available with a wide range of rated voltages.

(040125-1)

037

Gregor Kleine

When it is necessary to send a digital signal between two electrically isolated circuits you would normally choose an optoisolator or some form of transformer coupling. Neither of these solutions is ideal; optocouplers run out of steam beyond about 10 MHz and transformers do not have a good low frequency (in the region of Hertz) response. The company NVE Corporation (www.nve.com) produces a range of coupler devices using an innovative 'IsoLoop' technology allowing data rates up to 110 Mbaud.

The example shown here uses the IL715 type coupler providing four TTL or CMOS compatible channels with a data rate of 100 Mbit/s. Inputs and outputs are compatible with 3.3 V or 5 V systems. The maximum isolation voltage is 2.5 kV and the device can cope with input transients up to 20 kV/ μ s. The company produce many other configurations including bi-directional versions that would be suitable for RS485 interfacing.

The IsoLoop coupler is based on relatively new GMR (GiantMagnetoResistive) tech-

Digital Isolation up to 100 MBit/s

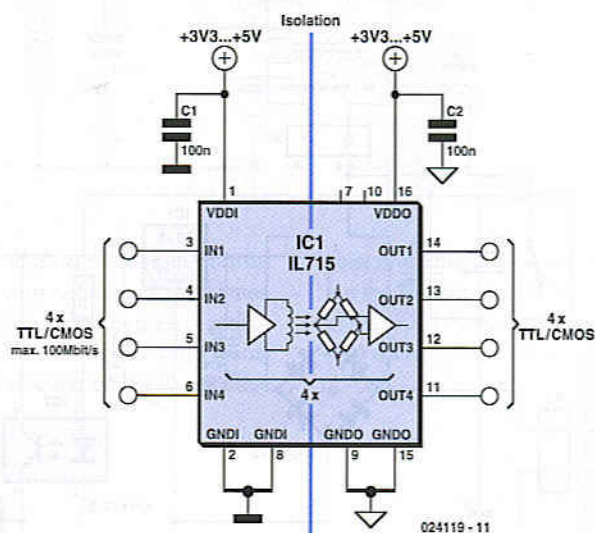

nology. The input signal produces a current in a planar coil. This current generates a magnetic field that produces a change in resistance of the GMR material. This material is isolated from the planar coil by a thin film high voltage insulating layer. The change in resistance is amplified and fed to a comparator to produce a digital output signal. Differences in the

ground potential of either the input or output stage will not produce any current flow in the planar coil and therefore no magnetic field changes to affect the GMR material. Altogether the circuit provides a good electrical isolation between input and output and also protects against input signal transients (EMV).

(024119-1)

038

Gregor Kleine

Maxim (www.maxim-ic.com) has produced a completely self-contained TTL oscillator chip in a very small three-pin

One Component Oscillator for 1 to 10 MHz

outline. The MAX7375 family of oscillators operates in the range of 1 MHz up to around 10 MHz, (depending on device suffix) and requires no external components. It may be necessary to fit a

100 nF decoupling capacitor across the supply pins if the chip is sited further than a few centimetres from any other decoupling capacitor. The specified supply voltage range is between 2.7 V and 5.5 V

while current consumption is dependant on clock frequency; at 4 MHz the chip takes 4 mA while at 8 MHz this rises to 6.5 mA. The device is available in an SOT23 package outline (MAX7375AUR) or in the even smaller SC70 outline (MAX7375AXR). Note that the pin-out definitions for these two outlines are not identical, the functions of pins 1 and pin 2 are swapped.

The accuracy of the output frequency is guaranteed to be within $\pm 2\%$ of nominal with a supply voltage of 3 V. Over the entire temperature range this rises to a maximum of $\pm 4\%$. This chip is currently available in a range of seven frequencies shown in the table below. The TTL push-pull output stage can sink and source up to 10 mA. The rise and fall times of the oscillator output are in the order of 5 ns while the mark-space ratio lies between 45 % and 57 %.

The MAX7375 offers a smaller, more cost-effective and mechanically more robust alternative to the conventional crystal or ceramic filter type of oscillator. The device has a wide operating temperature range of $-40\text{ }^{\circ}\text{C}$ to $+125\text{ }^{\circ}\text{C}$ and this

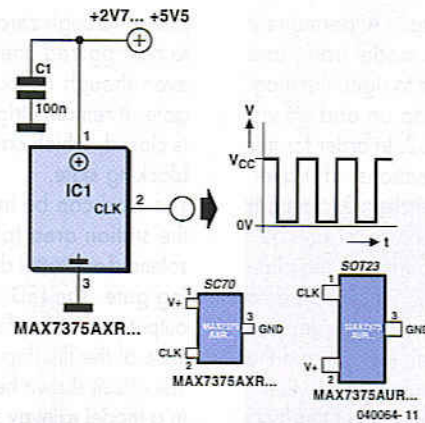

SOT23 MAX 7375AUR...	SC70 MAX 7375AXR...	Nominal Output Frequency
...105		1 MHz
...185		1.8432 MHz
...365		3.579545 MHz
...375		3.6864 MHz
...405		4 MHz
...425		4.1943 MHz
...805		8 MHz

makes it particularly suitable for auto-

motive applications.

(040064-1)

Power Flip-Flop Using a Triac

039

R. Edlinger

Modern electronics is indispensable for every large model railroad system, and it provides a solution to almost every problem. Although ready-made products are exorbitantly expensive, clever electronics hobbyists try to use a minimum number of components to achieve optimum results together with low costs. This approach can be demonstrated using the rather unusual semiconductor power flip-flop described here.

A flip-flop is a toggling circuit with two stable switching states (bistable multivibrator). It maintains its output state even in the absence of an input pulse. Flip-flops can easily be implemented using triacs if no DC voltage is available. Triacs are also so inexpensive that they are often used by model railway builders as semiconductor power switches. The decisive advantage of triacs is that they are bi-directional, which means they can be triggered during both the positive and the negative half-cycle by applying an AC voltage to the

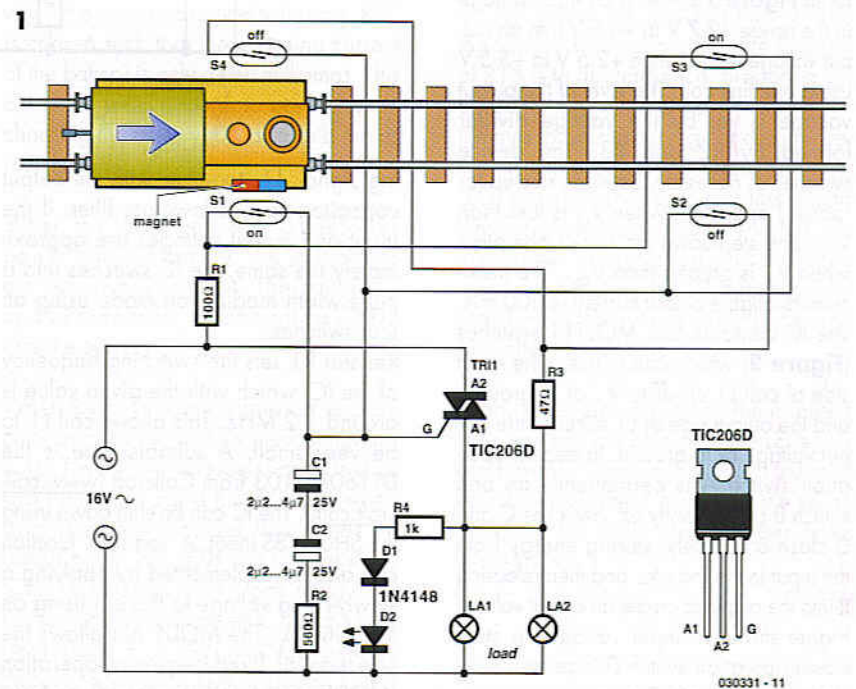

gate electrode (G). The polarity of the triggering voltage is thus irrelevant. Triggering

with a DC current is also possible.

Figure 1 shows the circuit diagram of

such a power flop-flop. A permanent magnet is fitted to the model train, and when it travels from left to right, the magnet switches the flip-flop on and off via reed switches S1 and S2. In order for this to work in both directions of travel, another pair of reed switches (S3 and S4) is connected in parallel with S1 and S2. Briefly closing S1 or S3 triggers the triac. The RC network C1/R2, which acts as a phase shifter, maintains the trigger current. The current through R2, C1 and the gate electrode (G) reaches its maximum value when the voltage across the load

passes through zero. This causes the triac to be triggered anew for each half-cycle, even though no pulse is present at the gate. It remains triggered until S2 or S4 is closed, which causes it to return to the blocking state.

The load can be incandescent lamps in the station area (platform lighting) or a solenoid-operated device, such as a crossing gate. The LED connected across the output (with a rectifier diode) indicates the state of the flip-flop.

The circuit shown here is designed for use in a model railway system, but there is no

reason why it could not be used for other applications. The reed switches can also be replaced by normal pushbutton switches.

For the commonly used TIC206D triac, which has a maximum current rating of 4 A, no heat sink is necessary in this application unless a load current exceeding 1 A must be supplied continuously or for an extended period of time. If the switch-on or switch-off pulse proves to be inadequate, the value of electrolytic capacitor C1 must be increased slightly.

(030331-1)

040

Buck/Boost Voltage Converter

Gregor Kleine

Sometimes it is desired to power a circuit from a battery where the required supply voltage lies within the discharge curve of the battery. If the battery is new, the circuit receives a higher voltage than required, whereas if the battery is towards the end of its life, the voltage will not be high enough. This is where the new LTC 3440 buck/boost voltage converter from Linear Technology (www.linear.com) can help. The switching regulator in **Figure 1** converts an input voltage in the range +2.7 V to +4.5 V into an output voltage in the range +2.5 V to +5.5 V using one tiny coil. The level of the output voltage is set by the voltage divider formed by R2 and R3. The device switches as necessary between step-up (or 'boost') operation when V_{in} is less than V_{out} , and step-down (or 'buck') operation when V_{in} is greater than V_{out} . The maximum available output current is 600 mA. The IC contains four MOSFET switches (**Figure 2**) which can connect the input side of coil L1 either to V_{in} or to ground, and the output side of L1 either to the output voltage or to ground. In step-up operation switch A is permanently on and switch B permanently off. Switches C and D close alternately, storing energy from the input in the inductor and then releasing it into the output to create an output voltage higher than the input voltage. In step-down operation switch D is permanently closed and switch C permanently open. Switches A and B close alternately and so create a lower voltage at V_{out} in proportion to the mark-space ratio of the switch-

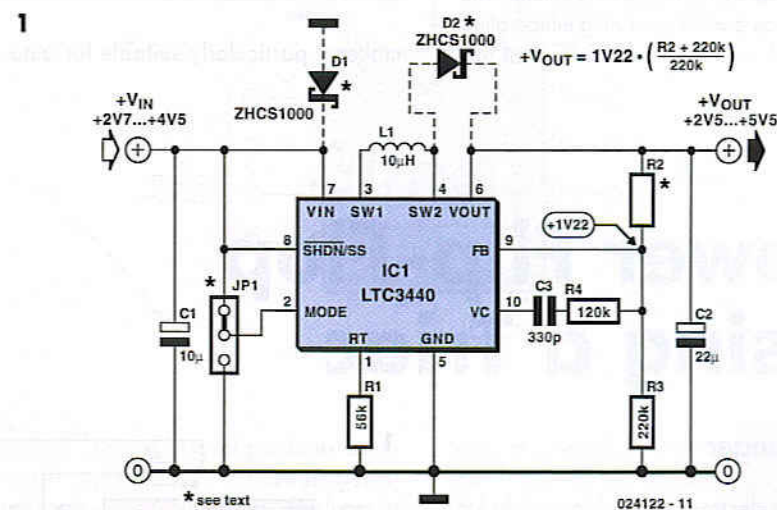

ing signal. L1, together with the output capacitor, form a low-pass filter. If the input and output voltages are approximately the same, the IC switches into a pulse-width modulation mode using all four switches.

Resistor R1 sets the switching frequency of the IC, which with the given value is around 1.2 MHz. This allows coil L1 to be very small. A suitable type is the DT1608C-103 from Coilcraft (www.coilcraft.com). The IC can be shut down using the SHDN/SS input. A 'soft start' function can also be implemented by applying a slowly-rising voltage to this pin using an RC network. The MODE pin allows the selection of fixed-frequency operation (MODE connected to ground) or burst mode operation (MODE= V_{in}). The latter offers higher efficiency (of between 70 % and 80 %) at currents below 10 mA. At

currents of around 100 mA the efficiency rises to over 90 %. A further increase in efficiency can be obtained by fitting the two Schottky diodes shown dotted in the circuit diagram. These operate during the brief period when both active switches are open (break-before-make operation).

(024122-1)

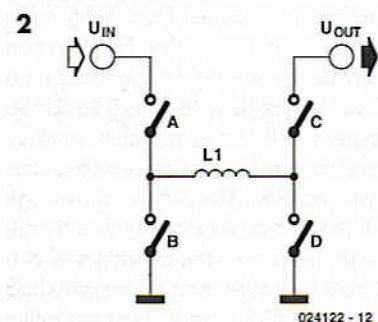

Mains Voltage Monitor

04

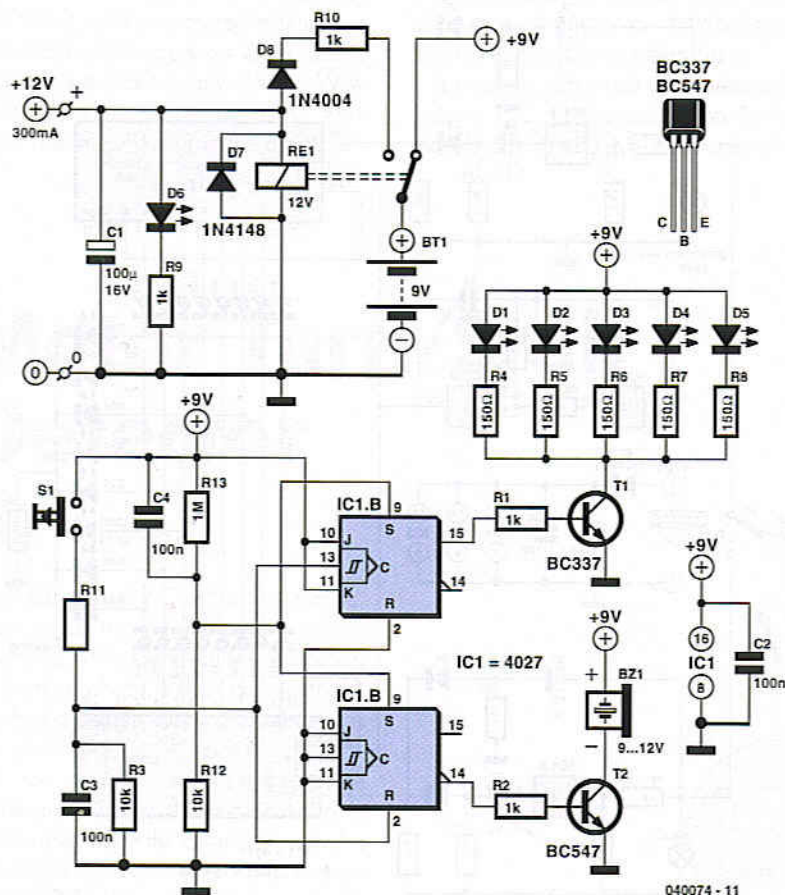

040074 - 11

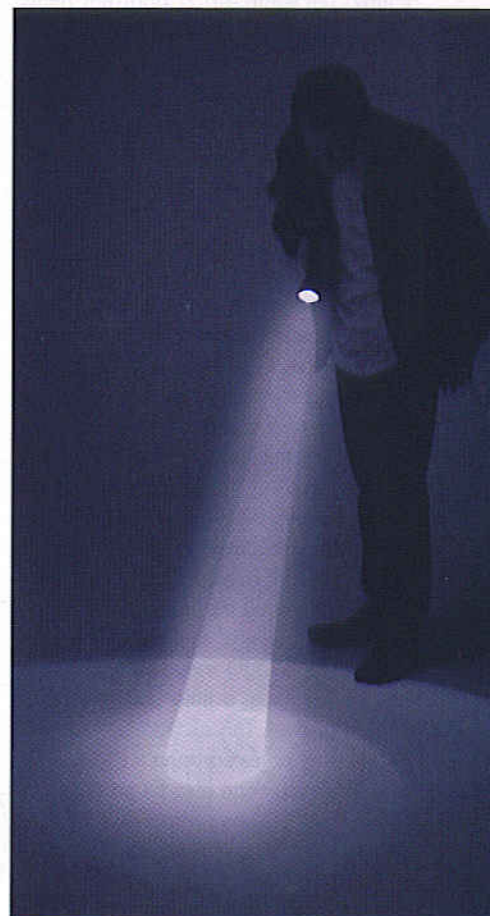

Goswin Visschers

Many electronics hobbyists will have experienced the following: you try to finish a project late at night, and the mains supply fails. Whether that is caused by the electricity board or your carelessness isn't really important. In any case, at such times you may find yourself without a torch or with flat batteries. There is no need to panic, as this circuit provides an emergency light.

When the mains fails, the mains voltage monitor turns on five super bright LEDs, which are fed from a 9 V battery (NiCd or NiMH) or 7 AA cells. A buzzer has also been included, which should wake you from your sleep when the mains fails. You obviously wouldn't want to oversleep because your clock radio had reset, would you?

When the mains voltage is present, the battery is charged via relay Re1, diode D8 and resistor R10. D8 prevents the battery voltage from powering the relay, and

makes sure that the relay switches off when the mains voltage disappears. R10 is chosen such that the charging current of the battery is only a few milliamps. This current is small enough to prevent overcharging the battery. D6 acts as a mains indicator.

When the relay turns off, IC1 receives power from the battery. The JK flip-flops are set via R12 and C4. This causes T1 and T2 to conduct, which turns on D1-D5 and the buzzer.

When the push button is pressed, a clock pulse appears on the CLK input of flip-flop IC1b. The output then toggles and the LEDs turn off. At the same time IC1a is reset, which silences the buzzer. If you press the button again, the LEDs will turn on since IC1b receives another clock pulse. The buzzer remains off because IC1a stays in its reset state. R11, R3 and C3 help to debounce the push button signal. In this way the circuit can also be used as a torch, especially if a separate mains adapter is used as the power supply.

As soon as the mains voltage is restored, the relay turns on, the LEDs turn off and the battery starts charging. The function of R13 is to discharge C4, preparing the circuit for the next mishap.

If mains failures are a regular occurrence, we recommend that you connect pairs of LEDs in series. The series resistors should then have a value of 100 Ω. This reduces the current consumption and therefore extends the battery life. This proves very useful when the battery hasn't recharged fully after the last time.

In any case, you should buy the brightest LEDs you can get hold of. If the LEDs you use have a maximum current of 20 mA, you should double the value of the series resistors! You could also consider using white LEDs.

(040074-1)

Blinker Indicator

Ludwig Libertin

This circuit represents a somewhat unusual blinker indicator for use in a car or model. The running-light display progresses toward the left or the right depending on which directional signal is activated. That's pretty cool if you're fond of light-show effects.

The circuit consists of two counters (IC2 and IC3), which are reset to zero via C4 or C7 respectively whenever a blinker lamp (La) illuminates. The running-light display thus runs through once and then stops, since the highest counter output is connected to the Enable input. When the lamp goes out, a new reset pulse is issued to the relevant counter by NAND gate IC1.A or IC1.B respectively, and the counter counts all the way up again. The progression rate of the display can be adjusted to the right speed using P1. Only one LED is on at a time (except for the hazard blinker). This allows the brightness to be easily adjusted using R12. Incidentally, the circuit can also be modified by replacing the normal diodes with LEDs, with all of the cathodes connected to ground via R12.

(034021-1)

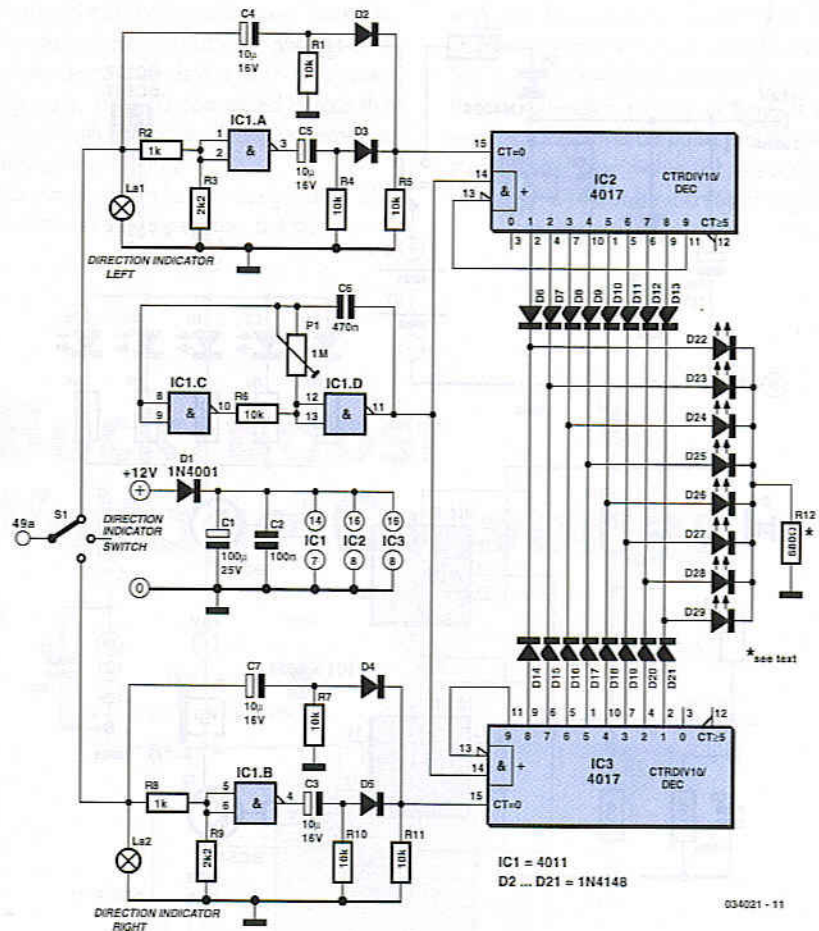

UV Torch Light

Myo Min

UV (ultra-violet) LEDs can produce eye-catching effects when their light is allowed to interfere with certain colours, particularly with reflected light under near-dark conditions. Also try shining some UV light on a diamond...

Most UV LEDs require about 3.6 V (the 'blue' diode voltage) to light. Here, a MAX761 step-up switching IC is used to provide constant current to bias the UV diode. The IC employs PWM in high-current mode and automatically changes to PFM mode in low or medium power mode to save (battery) power. To allow it to be used with two AA cells, the

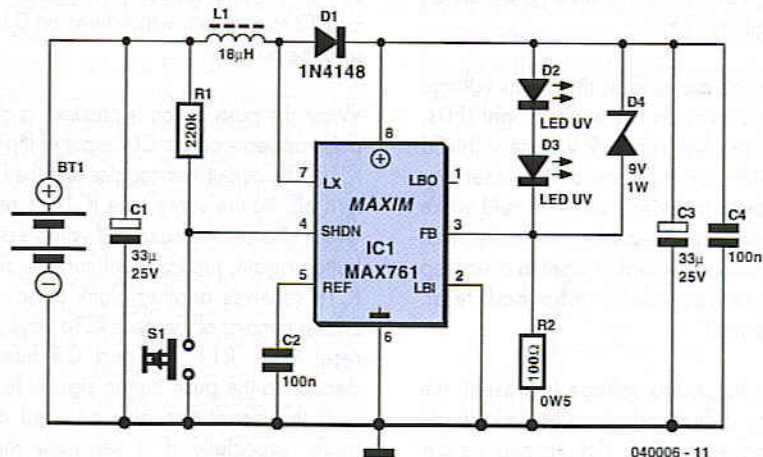

MAX761 is configured in bootstrapped mode with voltage-adjustable feedback. Up to four cells may be used to power the circuit but they may add more weight than you would like for a torchlight. To prolong the switch life, R1 is connected to the IC's SHDN (shutdown) pin. Less than 50 nA will be measured in shutdown mode. Electrolytic capacitor C1 is used to decouple the circuit supply voltage. Without it, ripple and noise may cause instability. The one inductor in the circuit, L1,

may have any value between about 10 and 50 μ H. It stores current in its magnetic field while the MOSFET inside the MAX761 is switched. A toroid inductor is preferred in this position as it will guarantee low stray radiation. D1 has to be a relatively fast diode so don't be tempted to use an 1N400x because it has a too slow recovery time. The circuit efficiency was measured at about 70%. R2, the resistor on the feedback pin of the MAX761 effectively

determines the amount of constant current, I , sent through the UV LEDs, as follows: $R2 = 1.5 / I$ where I will be between 2 mA and 35 mA. Zener diode D4 clamps the output voltage when the load is disconnected, which may happen when one of the UV LEDs breaks down. Without a load, the MAX761 will switch L1 right up to the boost voltage and so destroy itself.

(040006-1)

Motor Turn/Stall Detector

Karel Walraven

In single phase AC induction motors, often used in fridges and washing machines, a start winding is used during the starting phase. When the motor has reached a certain speed, this winding is turned off again.

The start winding is slightly out of phase to the run winding. The motor will only start turning when the current through this winding is out of phase to that of the run winding. The phase difference is normally provided by placing a capacitor of several μ F in series with the start winding. When the motor reaches a minimum speed, a centrifugal switch turns off the start winding. The circuit diagram doesn't show a centrifugal switch; instead it has a triac that is turned on during the starting phase. For clarity, the series capacitor isn't shown in the diagram.

Once the motor turns it will continue to do so as long as it isn't loaded too much. When it has to drive too heavy a load it will almost certainly stall. A large current starts to flow (as the motor no longer generates a back EMF), which is limited only by the resistance of the winding. This causes the motor to overheat after a certain time and causes permanent damage. It is therefore important to find a way to detect when the motor turns, which happens to be surprisingly easy.

When the motor is turning and the start winding is not used, the rotation induces a voltage in this winding. This voltage will be out of phase since the winding is in a different position to the run winding. When the motor stops turning this voltage is no longer affected and will be in phase with the mains voltage. The graph shows

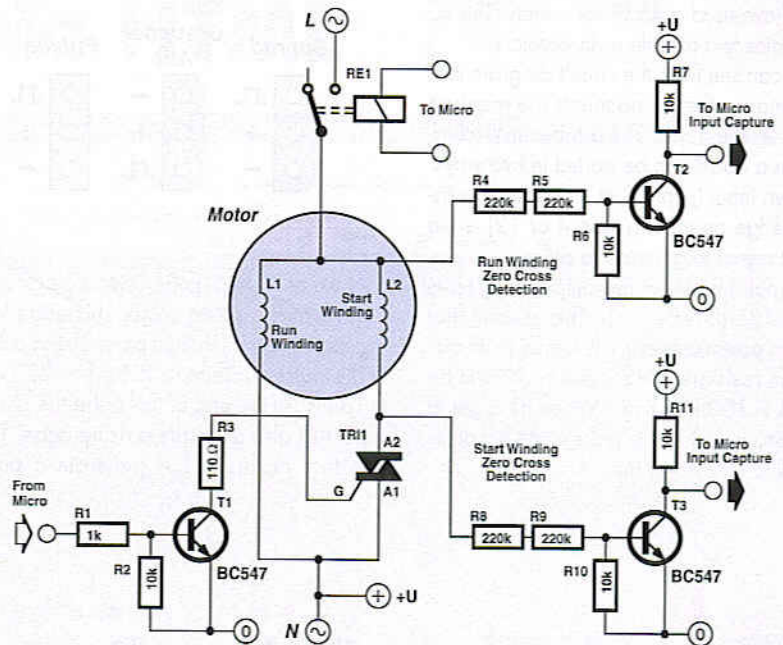

044027 - 11

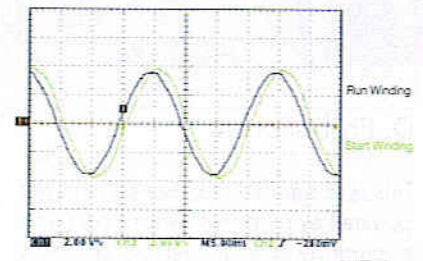
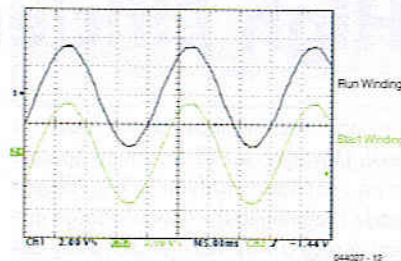

some of the relevant waveforms. More information can be found in the application note for the AN2149 made by Motorola, which can be downloaded from their website at www.motorola.com. We think this contains some useful ideas, but keep in mind that the circuit shown is

only partially completed. As it stands, it certainly can't be put straight to use. We should also draw your attention to the fact that mains voltages can be lethal, so take great care when the mains is connected!

(044027-1)

Servo Tester using a 4538

Paul Goossens

There are times when a small servo tester for modelling comes in very useful. Everybody who regularly works with servos will know several instances when such a servo tester will come in handy. The function of a servo tester is to generate a pulsing signal where the width of the positive pulse can be varied between 1 and 2 ms. This pulse-width determines the position the servo should move to. The signal has to repeat itself continuously, with a frequency of about 40 to 60 Hz. We have already published other servo testers in the past. These circuits often use an NE555 or one of its derivatives to generate the pulses. This time we have used a 4538 for variety. This IC contains two astable multi-vibrators.

You can see from the circuit diagram that not many other components are required besides the 4538. The astable multi-vibrator in a 4538 can be started in two ways. When input I_0 (pin 5 or 11) is high, a rising edge on input I_1 (pin 4 or 12) is the start signal to generate a pulse.

The pulse-width at the output of IC1.A is equal to $(R1+P1) \times C1$. This means that when potentiometer P1 is turned to its minimum resistance, the pulse-width will be $10\text{ k} \times 100\text{ n} = 1\text{ ms}$. When P1 is set to maximum (10 k), the pulse-width becomes $20\text{ k} \times 100\text{ n} = 2\text{ ms}$.

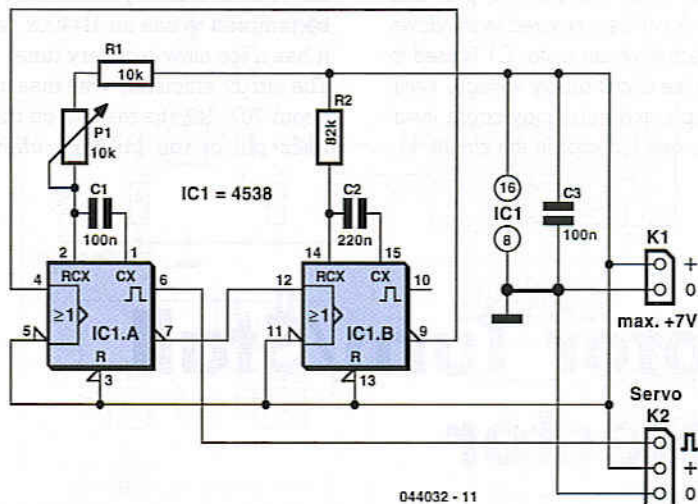

044032 - 11

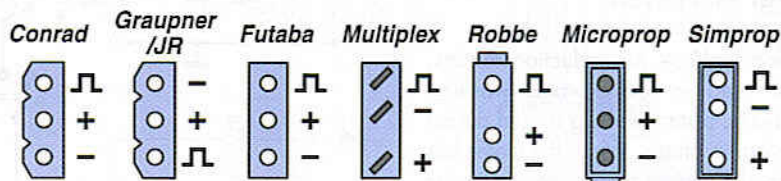

044032 - 12

At the end of this pulse inverting output \bar{Q} generates a rising edge. This edge triggers IC1.B, which then generates a pulse. The pulse-width here is $82\text{ k} \times 220\text{ n} \approx 18\text{ ms}$. At the end of this pulse the \bar{Q} output will also generate a rising edge. This in turn makes IC1.A generate a pulse

again. This completes the circle. Depending on P1, the total period is between 19 and 20 ms. This corresponds to a frequency of about 50 to 53 Hz and is therefore well within the permitted frequency range.

(044032)

Solar-Powered High Efficiency Charger

D. Prabakaran

This is a simple NiCd battery charger powered by solar cells. A solar cell panel or an array of solar cells can charge a battery at more than 80 % efficiency provided the available voltage exceeds the 'fully charged' battery voltage by the drop across one diode, which is simply inserted between the solar cell array and the battery. Adding a step-down regulator enables a solar cell array to charge battery packs with various terminal voltages at optimum rates and with efficien-

cies approaching those of the regulator itself. However, the IC must then operate in an unorthodox fashion (a.k.a. 'Elektor mode') regulating the flow of charge current in such a way that the solar array output voltage remains near the level required for peak power transfer.

Here, the MAX639 regulates its input voltage instead of its output voltage as is more customary (but less interesting). The input voltage is supplied by twelve amorphous solar cells with a minimum surface area of 100 cm^2 .

Returning to the circuit, potential divider R2/R3 disables the internal regulating loop by holding the V-FB (voltage feedback) terminal low, while divider R1/R2+R3 enables LBI (low battery input) to sense a decrease in the solar array output voltage. The resulting deviation from the solar cells' peak output power causes LBO (low battery output) to pull SHDN (shutdown) low and consequently disable the chip. LBI then senses a rising input voltage, LBO goes high and the pulsating control maintains maximum power transfer to the NiCd cells. Current limit-

ing inside the MAX639 creates a 'ceiling' of 200 mA for I_{out} . Up to five NiCd cells may be connected in series to the charger output.

When 'on' the regulator chip passes current from pin 6 to pin 5 through an internal switch representing a resistance of less than 1 ohm. Benefiting from the regulator's low quiescent current (10 microamps typical) and high efficiency (85%), the circuit can deliver four times more power than the single-diode configuration usually found in simple solar chargers. Coil L1 is a 100- μ H suppressor choke rated for 600 mA.

(020233-1)

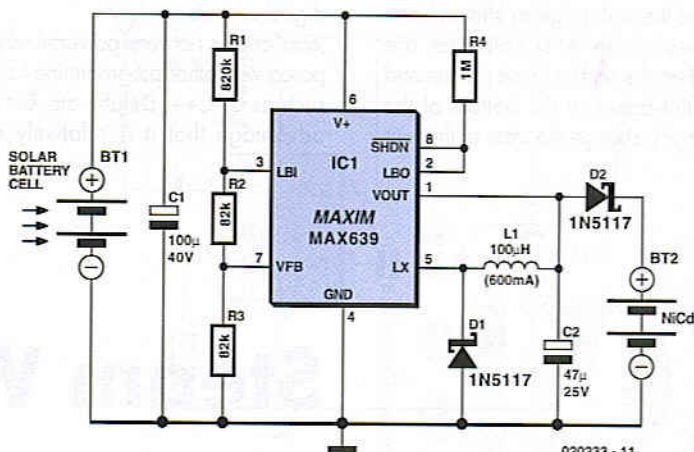

USB Converter Controlled via HTML

047

Paul Goossens

In this issue we publish an ActiveX component, which can be used to control the USB analogue converter (*Elektor Electronics*, November 2003). In this way, programmers can use C/C++, Delphi, VB etc. to include the converter in their own application.

It is maybe less well known that these ActiveX components can also be used from web browsers that support scripts and ActiveX. For this reason we've created an example HTML file, which uses JavaScript and ActiveX to control the USB converter. This file is available as a Free Download from <http://www.elektor-electronics.co.uk/> (044034-11).

To place an ActiveX component onto a web page you have to make use of the <OBJECT> tag. In this a name and a CLASSID have to be specified. This CLASSID is a number that indicates which type of ActiveX component should be used. Since it is impractical to remember all these number by heart, Microsoft have made a program available called ActiveX Control Pad. With this program it becomes easy to place an ActiveX component onto a web page and adapt its properties to your own liking.

Now that we've placed the ActiveX component onto the page, we can use JavaScript to send commands to this component or get it to return information. Here the JavaScript part sets up a communication channel with the USB converter when the page is opened. It also starts a

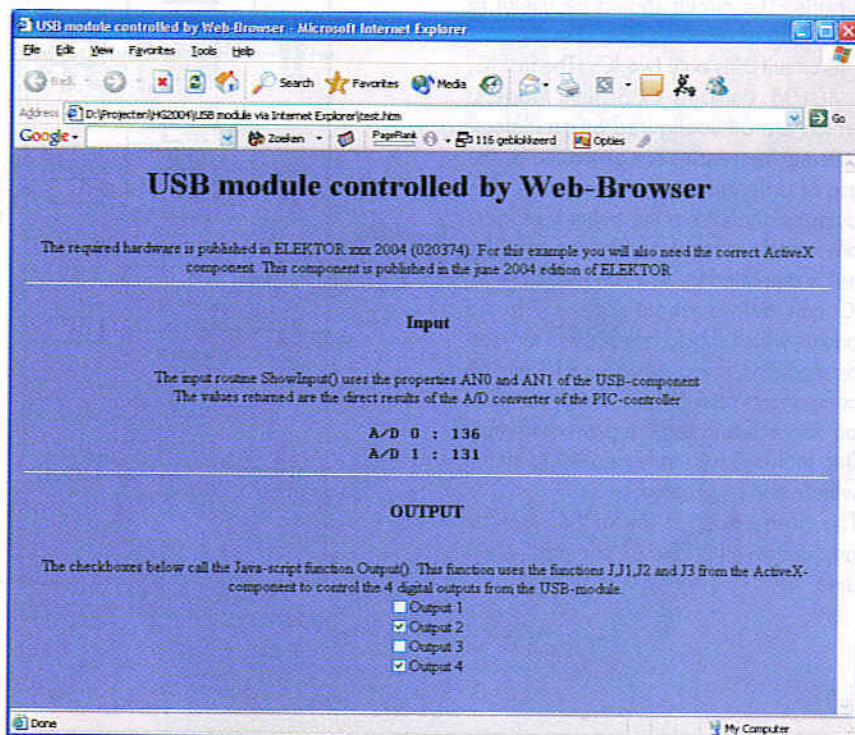

timer that calls the function ShowInput() every half a second.

The functions in JavaScript are very similar to those found in C. The three functions used in this example are simple enough for anyone with a bit of programming experience to follow. An important detail that should be mentioned is that every ActiveX component on the page is given a name during the initialisation. In this case, we have given the meaningful name 'USB' to the component that takes care of the communication with the USB module.

The two labels on this page have been creatively named as 'Label1' and 'Label2'. The previous tale sounds good, but does it work in practice? Everybody who has a USB analogue converter from the November 2003 issue of *Elektor Electronics* and who has installed this month's ActiveX component, can try it out very quickly. The USB converter first has to be connected via a USB cable. Then you should open the file 'test.htm'. If you have a web browser that supports ActiveX and JavaScript (such as Internet Explorer), you

should see the web page as shown here. The values of the A/D converter are refreshed on the screen twice per second and the tick-boxes at the bottom of the screen let you change the state of the four

digital outputs. JavaScript is not very powerful when compared with other programming languages such as C, C++, Delphi, etc, but has the advantage that it is relatively easy to

understand. Furthermore, everybody who has a standard Windows operating system installed on their PC can get started straight away.

(044034-1)

048

Steam Whistle

Gert Baars

This circuit consists of six square wave oscillators. Square waves are made up of a large number of harmonics. If six square waves with different frequencies are added together, the result will be a signal with a very large number of frequencies. When you listen to the result you'll find that it is very similar to a steam whistle. The circuit should be useful in modelling or even in a sound studio.

This circuit uses only two ICs. The first IC, a 40106, contains six Schmitt triggers, which are all configured as oscillators. Different frequencies are generated by the use of different feedback resistors. The output signals from the Schmitt triggers are mixed via resistors. The resulting signal is amplified by IC2, an LM386. This IC can deliver about 1 W of audio power, which should be sufficient for most applications. If you leave out R13 and all components after P1, the output can then be connected to a more powerful amplifier. In this way a truly deafening steam whistle can be created.

The 'frequency' of the signal can be adjusted with P2, and P1 controls the volume.

(044002-1)

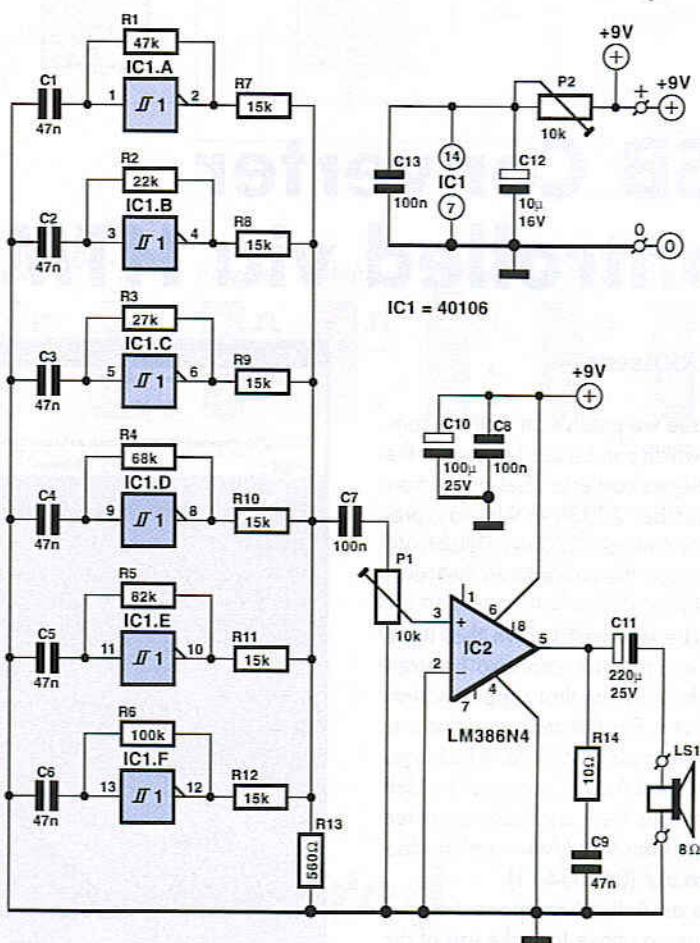

049

Single-Chip VHF RF Preamp

D. Prabakaran

Here is a high performance RF amplifier for the entire VHF broadcast and PMR band (100-175 MHz) which can be successfully built without any special test

equipment. The grounded-gate configuration is inherently stable without any neutralization if appropriate PCB layout techniques are employed. The performance of the amplifier is quite good. The noise figure is below 2 dB and the gain is over

13 dB. The low noise figure and good gain will help car radios or home stereo receivers pick up the lower-power local or campus radio stations, or distant amateur VHF stations in the 2-metres band. Due to the so-called threshold effect, FM receivers

loose signals abruptly so if your favourite station fades in and out as you drive, this amplifier can cause a dramatic improvement.

The MAX2633 is a low-voltage, low-noise amplifier for use from VHF to SHF frequencies. Operating from a single +2.7 V to +5.5V supply, it has a virtually flat gain response to 900 MHz. Its low noise figure and low supply current makes it ideal for RF receive, buffer and transmit applications. The MAX2633 is biased internally and has a user-selectable supply current, which can be adjusted by adding a single external resistor (here, R1). This circuit draws only 3 mA current.

Besides a single bias resistor, the only external components needed for the MAX2630 family of RF amplifiers are input and output blocking capacitors, C1 and C3, and a V_{CC} bypass capacitor,

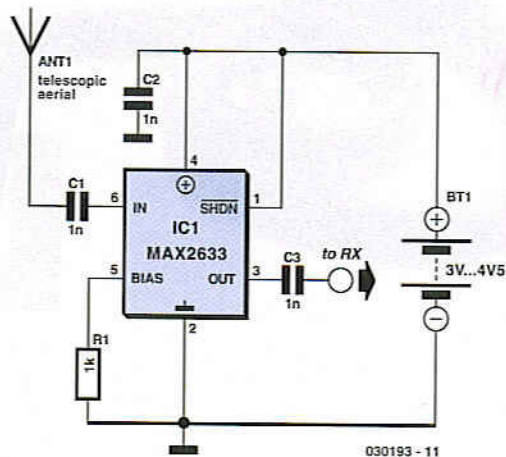

C2. The coupling capacitors must be large enough to contribute negligible reactance in a 50-Ω system at the lowest operating frequency. Use the following equation to calculate their minimum value:

$$C_c = 53000 / f_{low} \quad [\text{pF}]$$

Further information: www.maxim-ic.com.

(030193-1)

Codec Complete

050

Paul Goossens

Digital audio equipment usually contains an A/D and a D/A converter. In practice a codec is used for this. This is a chip where both converters are built-in and which often includes standard inputs and outputs for digital audio, such as I²S. Apart from this codec there is often a requirement for a microphone input and headphone output as well.

Texas Instruments has made a new codec, the TLV320AIC28, which has an integrated microphone pre-amplifier and a 400 mW headphone amplifier. A few other practical functions have also been added to this chip, such as 2 I/O pins for use in push-button control, microphone detector, etc.

It is therefore extremely suitable for use in combination with headsets.

The chip can be controlled via an SPI interface, which means that most micro-controllers can communicate easily with this codec. As we said earlier, the audio interface can take an I²S signal, but the audio interface is very flexible, as with many other codecs, and can cope with several other audio formats.

Should you be on the lookout for a codec and you intend to use a microphone input and headphone output, then this one



makes an excellent choice. More information for this codec can be found in its datasheet at the website of Texas Instruments:

<http://focus.ti.com/docs/prod/folders/print/tlv320aic28.html>

(044043-1)



Would
rather
what

*Read elektor
electronics.*

leading the way

Don't you ever know what's inside?



Take out an 18-month subscription to *elektor electronics* and receive a free 128-MB USB Memory Stick.

Please fill out the Order Form with this issue.

Subscription rates and conditions may be found at the back of this issue.

Mains Failure Alarm

Myo Min

This circuit was designed to produce an audible alarm when the mains power is interrupted. Such an alarm is essential for anyone whose livelihood depends on keeping perishable foodstuffs in cold storage.

The circuit is powered by a 12-V mains adapter. LED D5 will light when the mains voltage is present. When the mains voltage disappears, so does the +12 V supply voltage, leaving the voltage regulator IC1 and relay driver T1-T2 without power. The relay driver, by the way, is an energy-saving type, reducing the coil current to about 50% after a few seconds. Its operation and circuit dimensioning are discussed in the article 'Relay Coil Energy Saver'.

The value of the capacitor at the output of voltage regulator IC1 clearly points to a different use than the usual noise suppression. When the mains power disappears, Re1 is de-energised and the 0.22 F Goldcap used in position C4 provides supply current to IC2. When the mains voltage is present, C4 is charged up to about 5.5 volts with IC1 acting as a 100-mA current limit and D10 preventing current flowing back into the regulator output when the mains voltage is gone. According to the Goldcap manufacturer, current limiting is not necessary during charging but it is included here for the security's sake.

The CMOS 555 is configured in astable multivibrator mode here to save power, and so enable the audible alarm to sound

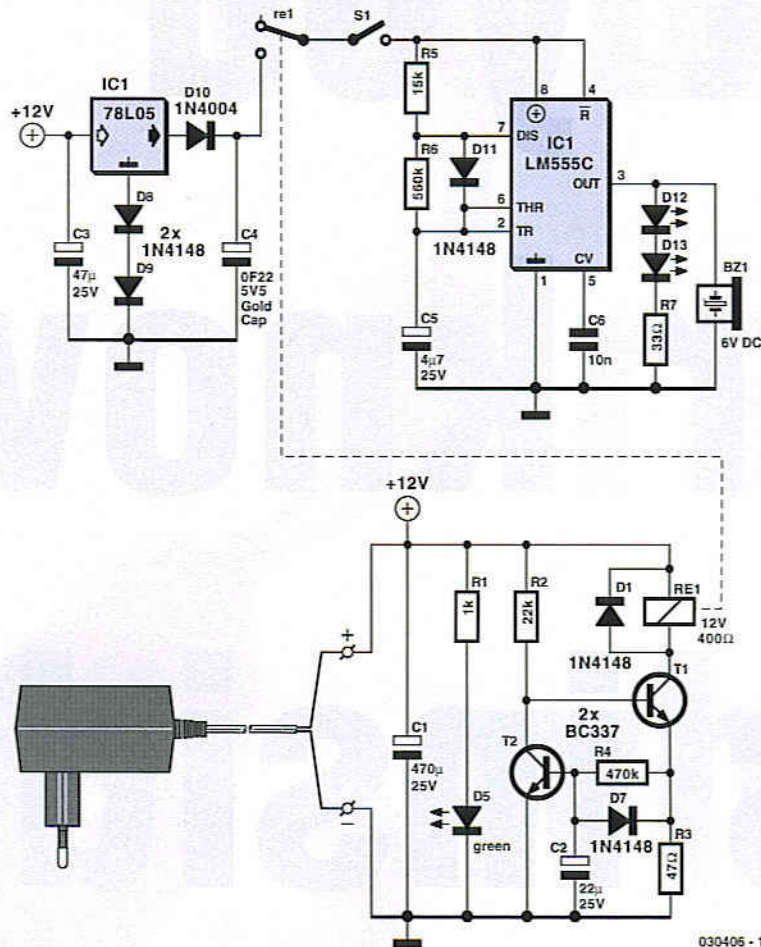

as long as possible. Resistors R5 and R6 define a short 'on' time of just 10 ms. That is, however, sufficient to get a loud warning from the active buzzer. In case the pulses are too short, increase the value of

R5 (at the expense of a higher average current drawn from the Goldcap).

(030406-1)

Push Off / Push On

Trevor Skeggs

The ubiquitous 555 has yet another airing with this bistable using a simple push-button to provide a push-on, push-off action. It uses the same principle of the stored charge in a capacitor taking a Schmitt trigger through its dead-band as previously published as 'Pushbutton

Switch' (038) in the *Small Circuits* collection of 2002.

Whereas the Schmitt trigger in that reference was made from discrete components, the in-built dead-band arising from the two comparators, resistor chain and bistable within the 555 is used instead. The circuit demonstrates a stand-by

switch, the state of which is indicated by illumination of either an orange or red LED, exclusively driven by the bipolar output of pin 3.

Open-collector output (pin 7) pulls-in a 100-mA relay to drive the application circuit; obviously if an ON status LED is provided elsewhere, then the relay, two LEDs and two resistors can be omitted, with

pin 3 being used to drive the application circuit, either directly or via a transistor. The original NE555 (non-CMOS) can source or sink 200 mA from / into pin 3. Component values are not critical; the 'dead-band' at input pins 2 and 6 is between 1/3 and 2/3 of the supply voltage. When the pushbutton is open-circuit, the input is clamped within this zone (at half the supply voltage) by two equal-value resistors, Rb. To prevent the circuit powering-up into an unknown condition, a power-up reset may be applied with a resistor from supply to pin 4 and capacitor to ground.

A capacitor and high-value resistor (Rt) provide a memory of the output state just prior to pushing the button and creates a dead time, during which button contact bounce will not cause any further change. When the button is pressed, the stored charge is sufficient to flip the output to the opposite state before the charge is dissipated and clamped back into the neutral

zone by resistors Rb. A minimum of 0.1 μF will work, but it is safer to allow for button contact-bounce

or hand tremble; 10 μF with 220 k Ω gives approximately a 2-second response.

(030176-1)

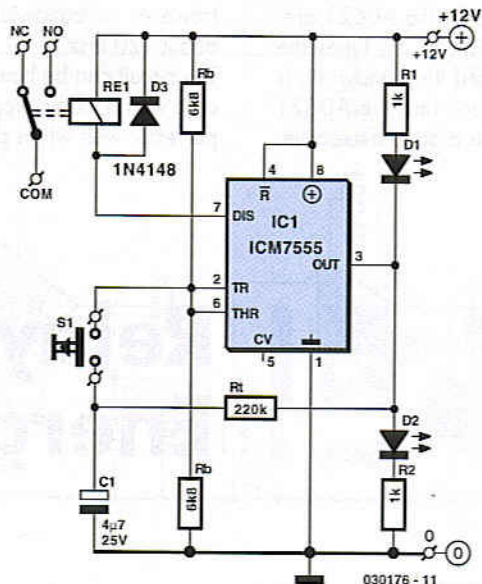

Meter Adapter with Symmetrical Input



Aart Rombout

In contrast to an ordinary voltmeter, the input of an oscilloscope generally has one side (GND) connected to ground via the mains lead. In certain situations this can be very problematic. When the measuring probe is connected to a circuit that is also connected to ground, there is a chance that a short is introduced in the circuit. That the circuit, and hence the measurement, is affected by this is the least of your problems. If you were taking measurements from high current or high voltage (valve equipment) circuits, the outcome could be extremely dangerous!

Fortunately it is not too difficult to get round this problem. All you have to do is make the input to the oscilloscope float with respect to ground. The instrumentation amplifier shown here does that, and functions as an attenuator as well. The AD621 from Analog Devices amplifies the input by a factor of 10, and a switch at the input gives a choice of 3 ranges. A 'GND' position has also been included, to calibrate the zero setting of the oscilloscope. The maximum input voltage at any setting may never exceed 600 V_{AC}. Make sure that R1 and R8

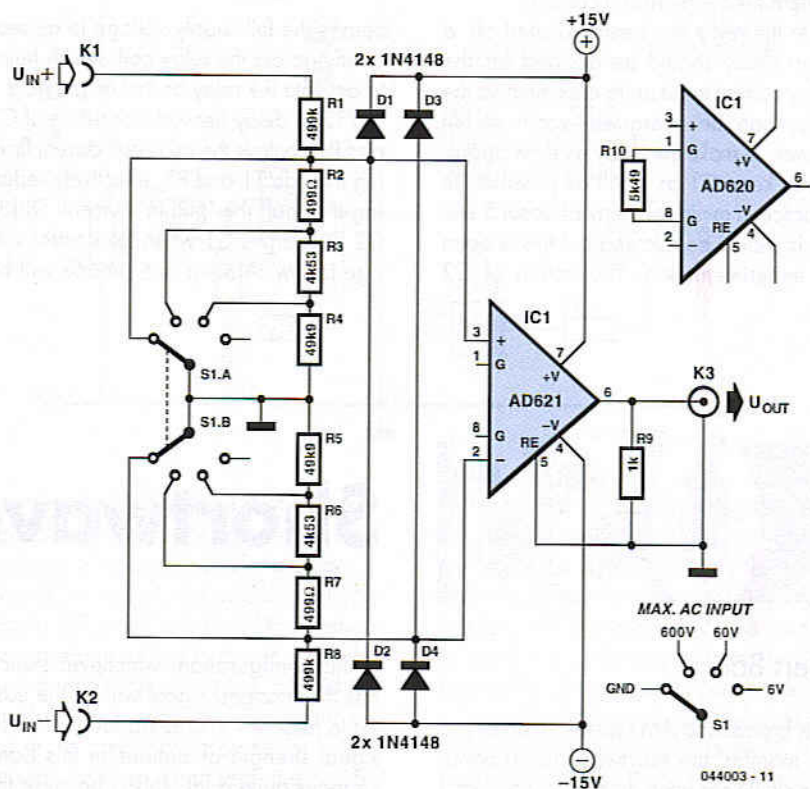

have a working voltage of at least 600 V. You could use two equal resistors connected in series for these, since

300 V types are more easily obtainable. You should also make sure that all resistors have a tolerance of 1% or better.

Other specifications for the AD621 are: with an amplification of 10 times the CMRR is 110 dB and the bandwidth is 800 kHz. If you can't find the AD621 locally, the AD620 is a good alternative.

However, the bandwidth is then limited to about 120 kHz.

The circuit can be housed inside a metal case with a mains supply, but also works perfectly well when powered from two

9 V batteries. The current consumption is only a few milliamps. You could also increase R9 to 10 k to reduce the power consumption a bit more.

(044003-1)

054

Relay Coil Energy Saver

Myo Min

Some relays will become warm if they remain energised for some time. The circuit shown here will actuate the relay as before but then reduce the 'hold' current through the relay coil current by about 50%, thus considerably reducing the amount of heat dissipation and wasted power. The circuit is only suitable for relays that remain on for long periods. The following equations will enable the circuit to be dimensioned for the relay on hand:

$$R3 = 0.7 / I$$

$$\text{Charge time} = 0.5 \times R2 \times C1$$

Where I is the relay coil current.

After the relay has been switched off, a short delay should be allowed for the relay current to return to maximum so the relay can be energised again at full power. To make the delay as short as possible, keep C1 as small as possible. In practice, a minimum delay of about 5 seconds should be allowed but this is open to experimentation. The action of C2

causes the full supply voltage to appear briefly across the relay coil, which helps to activate the relay as fast as possible. Via T2, a delay network consisting of C1 and R2 controls the relay coil current flowing through T1 and R3, effectively reducing it to half the 'pull in' current. Diode D2 discharges C1 when the control voltage is low. Around one second will be

needed to completely discharge C1. T2 shunts the bias current of T1 when the delay has elapsed. Diode D1 helps to discharge C1 as quickly as possible. The relay shown in the circuit was specified at 12 V / 400 ohms. All component values for guidance only.

(030188-1)

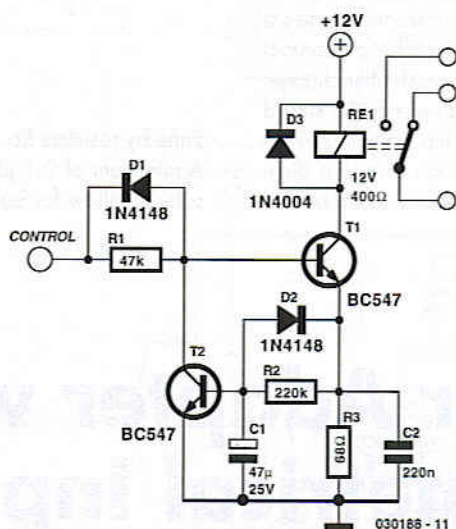

055

Shortwave Monitor

Gert Baars

This broadband AM receiver enables you to 'monitor' the shortwave radio band. The circuit has been deliberately designed to have low selectivity and is most sensitive in the range from 6 to 20 MHz. This frequency range contains most of the shortwave broadcast stations.

In this configuration, whichever station has the strongest signal will be the easiest to hear. An interesting fact is that the signal strength of stations in this band changes quite a lot. This is because the ionosphere reflects the radio signals. Because this layer of the atmosphere is in constant motion, the received signal strengths from different directions are sub-

ject to continuous variation. During testing of our prototype Radio Netherlands World Service, Radio Finland and Deutsche Welle alternated as the strongest station at regular intervals. This receiver not only gives a good indication of the myriad of stations on offer in the shortwave band but is also an excellent tool for monitoring the state of the ionosphere.

The LED brightness is determined by R4.

As a rule of thumb,

$$R4 = (V_{\text{supply}} - 2) / 3 \text{ [k}\Omega\text{]}$$

and remember that the 4093 can only supply a few mA's of output current.

Applications of this little circuit include 'non critical' ones such as go/non-go bat-

tery testers, simple temperature indicators, water tank level indicators, etc.

(049001-1)

057

Bluish Flasher

Myo Min

This circuit is innovative in more than one way and therefore belongs *per se* in Elektor's Small Circuits Collection. Firstly, it demonstrates how the combination of a blue and a white LED can be used to give a realistic imitation of a camera flashlight. Secondly, the good old 555 IC is used in a way many of you may never have seen before — alternately monostable / astable — without too much in the way of external parts.

Initially C3 will be empty, pulling output pin 3 to +12 V and causing the blue LED, D1, to light via R3. Next, C3 will charge up via R2. Meanwhile C1 has been building up charge through R1 and D3. If the voltage on C3 reaches about 8 V (two-thirds of 12 V), pin 3 of the 555 will drop low. So does pin 7, causing the white LED to light, pulling its energy from C1. This energy drops quickly, causing D2 to dim in an exponentially decaying fashion, just like a camera flashlight. Now, because the 555's output has dropped low, the voltage on C3 will decrease as well. As soon as a level of 4 V is reached

(one third of 12 V), the above cycle is repeated.

Resistor R4 limits the current through the 555 to safe levels. You may want to experiment with the latest hyper-bright white LEDs. SDK's AllnGaP LEDs, for example, are claimed to light three times as brightly as regular white LEDs.

A number of blue LEDs may be connected in series instead of just one as shown in

the circuit diagram. Unfortunately, that is not possible at the 'white' side. For the best visual effect, the white blue LEDs should be mounted close together. When fitted close to the extra brake light in your car, the bluish white flash is sure to make even persistent tailgaters back off. Note however that this use of the circuit may not be legal in all countries.

(030143-1)

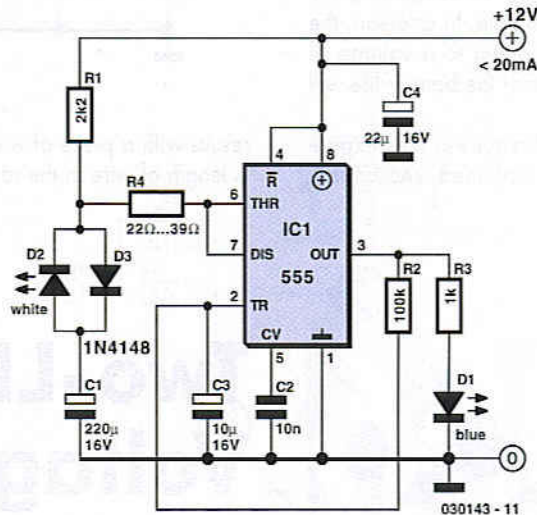

058

Very Low Power 32-kHz Oscillator

D. Prabakaran

The 32-kHz low-power clock oscillator offers numerous advantages over conventional oscillator circuits based on a CMOS inverter. Such inverter circuits present problems, for example, supply currents fluctuate widely over a 3-V to 6-V supply range, while current consumption below 250 μA is difficult to attain. Also,

operation can be unreliable with wide variations in the supply voltage and the inverter's input characteristics are subject to wide tolerances and differences among manufacturers.

The circuit shown here solves the above problems. Drawing just 13 μA from a 3-V supply, it consists of a one-transistor amplifier/oscillator (T1) and a low-power comparator/reference device (IC1). The

base of T1 is biased at 1.25 V using R5/R4 and the reference in IC1. T1 may be any small-signal transistor with a decent beta of 100 or so at 5 μA (defined here by R3, fixing the collector voltage at about 1 V below Vcc). The amplifier's nominal gain is approximately 2 V/V. The quartz crystal combined with load capacitors C1 and C3 forms a feedback path around T1, whose 180 degrees of phase

shift causes the oscillation. The bias voltage of 1.25 V for the comparator inside the MAX931 is defined by the reference via R2. The comparator's input swing is thus accurately centred around the reference voltage. Operating at 3 V and 32 kHz, IC1 draws just 7 μ A.

The comparator output can source and sink 40 mA and 5 mA respectively, which is ample for most low-power loads. However, the moderate rise/fall times of 500 ns and 100 ns respectively can cause standard, high-speed CMOS logic to draw higher than usual switching currents. The optional 74HC14 Schmitt trigger shown at the circuit output can handle the comparator's rise/fall times with only a small penalty in supply current. Further information on the MAX931 from: www.maxim-ic.com.

(020232-1)

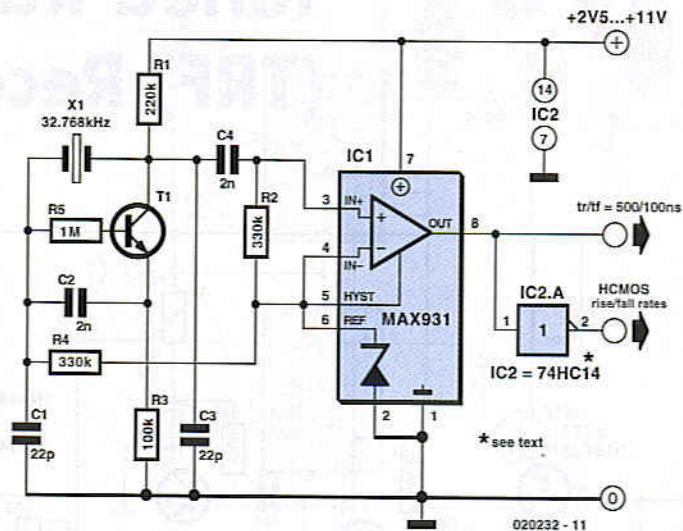

059

Master/Slave switch

Karl Köckeis

In this age of enlightenment any sort of relationship that could be described as master/slave would be questionable but for the purposes of this circuit it gives a good idea of how it functions. The circuit senses mains current supplied to a 'master' device and switches 'slave' equipment on or off. This feature is useful in a typical hi-fi or home computer environment where several peripheral devices can all be switched on or off together.

A solid-state relay from Sharp is an ideal switching element in this application; a built-in zero crossing detector ensures that switching only occurs when the mains voltage passes through zero and any resultant interference is kept to an absolute minimum. All of the triac drive circuitry (including optical coupling) is integrated on-chip so there are very few external components and no additional power supply necessary. This makes the finished design very compact.

Diodes D1, D2, D3 and D4 perform the current sensing function and produce a voltage on C2 when the master equipment is switched on. A Schottky diode is used for D5 to reduce forward voltage losses to a minimum. The circuit is quite

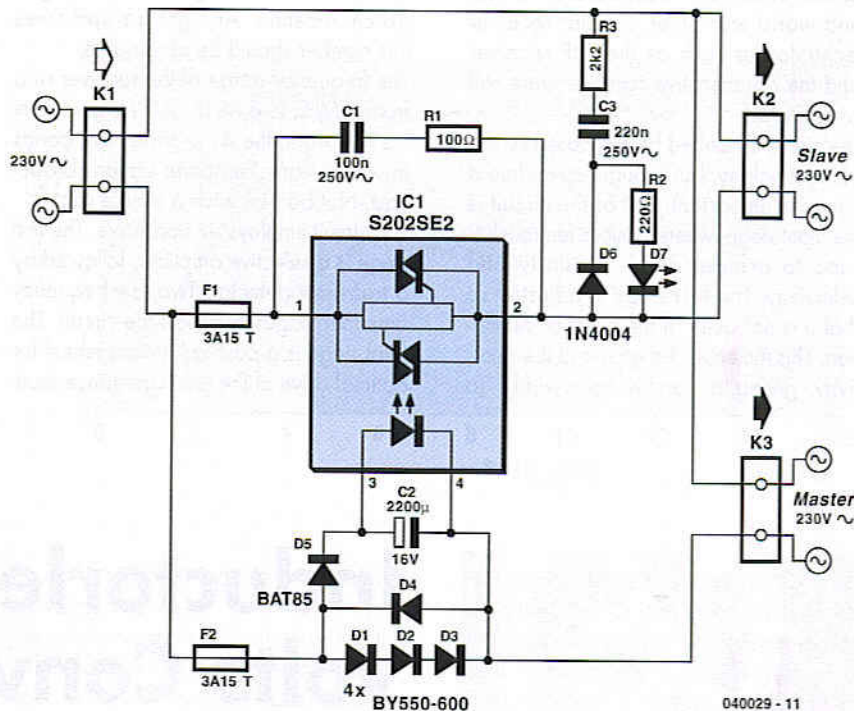

sensitive and will successfully switch the slave even when the master equipment draws very little mains current.

The RC network formed by R1 and C1 provides some protection for the solid-state relay against mains-borne voltage transients.

Warning: This circuit is connected to the mains. It is important to be aware that the chip has lethal voltages on its pins and all appropriate safety guidelines must be adhered to! This includes the LED, for safety it must be fitted behind a transparent plexiglass shield.

(040029-1)

060

Tuned Radio Frequency (TRF) Receiver

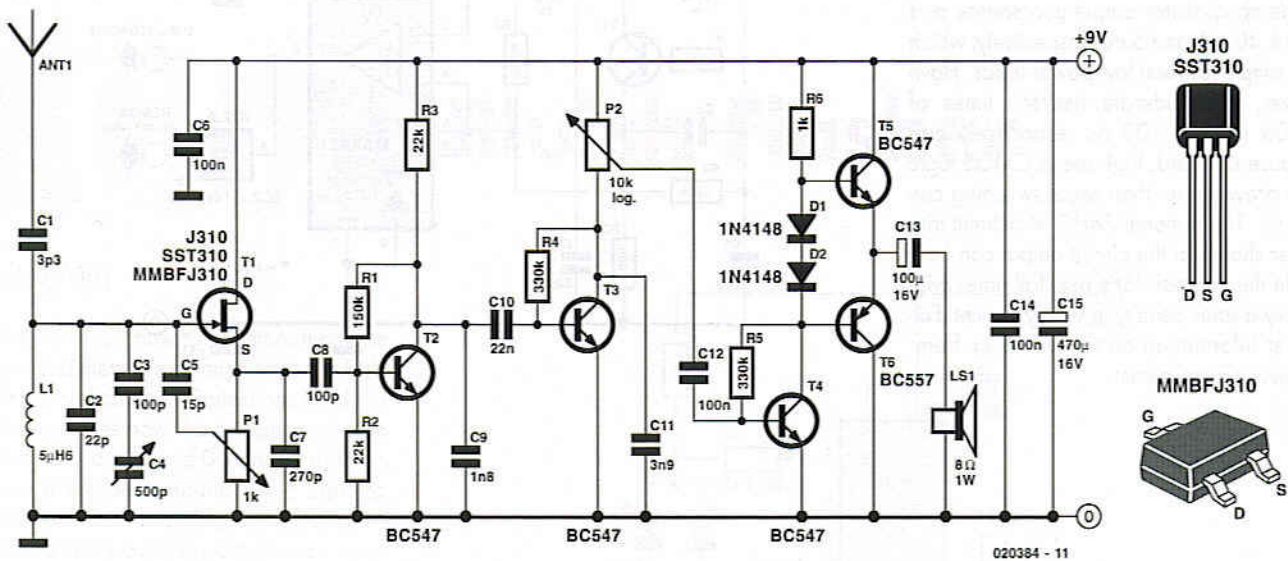

Gert Baars

Superheterodyne receivers have been mass-produced since around 1924, but for reasons of cost did not become successful until the 1930s. Before the second world war other, simpler receiver technologies such as the TRF receiver and the regenerative receiver were still widespread.

The circuit described here is based on the old technology, but brought up-to-date. The most important part of the circuit is the input stage, where positive feedback is used to achieve good sensitivity and selectivity. The first stage is adjusted so that it is not quite at the point of oscillation. This increases the gain and the selectivity, giving a narrow bandwidth. To

achieve this, the potentiometer connected to the drain of the FET must be adjusted very carefully: optimal performance of the receiver depends on its setting. In ideal conditions several strong stations should be obtainable during the day using a 50 cm antenna. At night, several times this number should be obtainable.

The frequency range of the receiver runs from 6 MHz to 8 MHz. This range covers the 49 m and the 41 m shortwave bands in which many European stations broadcast. Not bad for such a simple circuit! The circuit employs six transistors. The first stage is a selective amplifier, followed by a transistor detector. Two low-frequency amplifier stages complete the circuit. The final stage is a push-pull arrangement for optimal drive of the low-impedance loud-

speaker. This circuit arrangement is sometimes called a '1V2 receiver' (one preamplifier, one detector and two audio-frequency stages).

Setting-up is straightforward. Adjust P1 until the point is reached where the circuit starts to oscillate: a whistle will be heard from the loudspeaker. Now back off the potentiometer until the whistle stops. The receiver can now be tuned to a broadcaster. Occasional further adjustment of the potentiometer may be required after the station is tuned in.

The receiver operates from a supply voltage of between 5 V and 12 V and uses very little current. A 9 V PP3 (6F22) battery should give a very long life.

(020384-1)

06

Inductorless 3-to-5 Volts Converter

D. Prabakaran

By configuring a comparator and a transistor to control the oscillator in a charge pump circuit, you enable the pump to generate a regulated output of — in principle — any desired value. Charge pump ICs can either invert or double an input

voltage (for example, 3 V to -3 V or 3 V to 6 V). The charge pump itself does not regulate the output voltage and one running off 3 V is not normally capable of generating intermediate output voltage levels like 5 V. However, by adding a comparator and a reference device, you can create arbitrary output levels like 5 V

and regulate them as well.

Charge pump IC1 (a MAX660) has an internal oscillator whose 45 kHz operation transfers charge from C1 to C2, causing the regulated output to rise. When the feedback voltage (pin 3 of IC2) exceeds 1.18 V, the output of comparator IC2 (a MAX921) goes high, turn-

ing off the oscillator via T1.

The comparator hysteresis (easily added on IC2) is zero here simply because no hysteresis is required in the control loop. The oscillator when enabled generates two cycles, which is sufficient to drive V_{OUT} slightly above the desired level. Next, the feedback turns the oscillator off again. The resulting output ripple will depend mainly on the input voltage and the output load current. Output ripple may be reduced at the expense of circuit efficiency by adding a small resistor (say, $1\ \Omega$) in series with C1. You'll find that ripple also depends on the value and ESR associated with C1 — smaller values of C1 transfer less charge to C2, producing smaller jumps in V_{OUT} .

(020230-1)

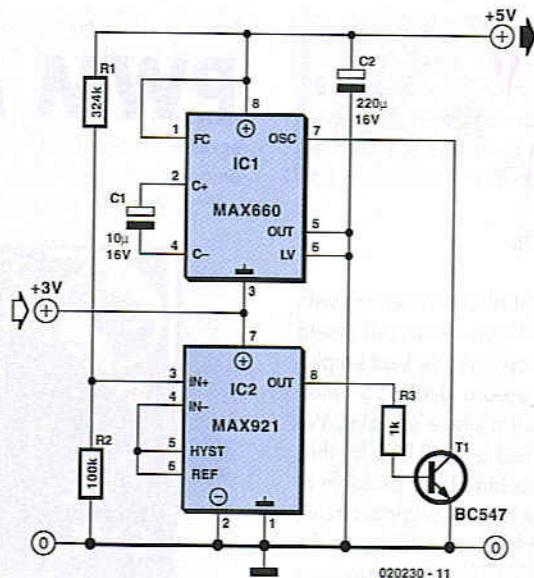

062

Stable Zener Reference

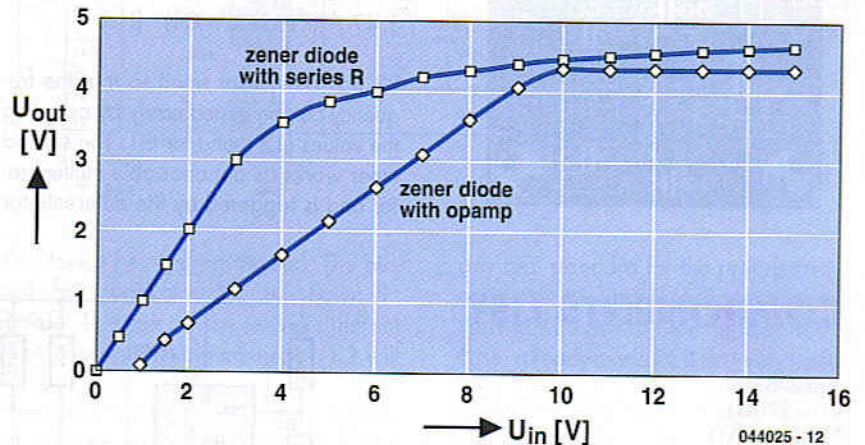
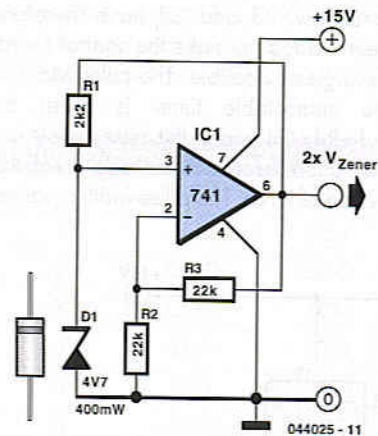

Karel Walraven

Nowadays some first-rate voltage references are available. Take the LM385 for example: this is available for different voltages and even comes in an adjustable version. What is more, the current consumption may be kept very small ($10\ \mu\text{A}$). But as often happens, you may not have one to hand when you need one for an experimental circuit.

In that case, you could use an ordinary zener diode for the reference. Unfortunately, they have a somewhat higher internal resistance (about $5\ \Omega$), which means

they won't be very stable when the supply voltage varies.

The solution is right in front of us: use the stabilised zener voltage as the supply voltage! This is obviously only possible if the stabilised voltage is higher than the zener voltage. It therefore has to be amplified a little. This is exactly what this circuit does: it amplifies it by a factor of two. The current limiting resistor should be chosen such that a current of 1 to 3 mA flows through the zener diode. Manufacturers usually state the zener voltage at a current between 3 to 5 mA.

The zener diode is fed from a stabilised

voltage and hence has a very stable operating point, which is independent from the supply voltage. The graph speaks for itself. It is clear that the output voltage is much more stable. The graphs have been plotted to different scales to make the comparison easier. In reality the opamp output is twice the zener voltage.

Zener diodes also have a temperature coefficient, which is smallest for types with a zener voltage around 5 volts. Virtually any type of opamp should be suitable; even our old friend the 741 works well enough.

(044025-1)

PWM Modulator

Ton Giesberts

If you ever thought of experimenting with pulse-width modulation, this circuit should get you started nicely. We've kept simplicity in mind and used a dual 555 timer, making the circuit a piece of cake. We have even designed a small PCB for this, so building it shouldn't be a problem at all. This certainly isn't an original circuit, and is here mainly as an addition to the 'Dimmer with MOSFET' article elsewhere in this issue. The design has therefore been tailored to this use.

A frequency of 500 Hz was chosen, splitting each half-period of the dimmer into five (a low frequency generates less interference). The first timer is configured as a standard astable frequency generator. There is no need to explain its operation here, since this can easily be found on the Internet in the datasheet and application

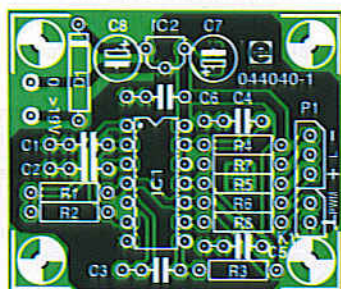
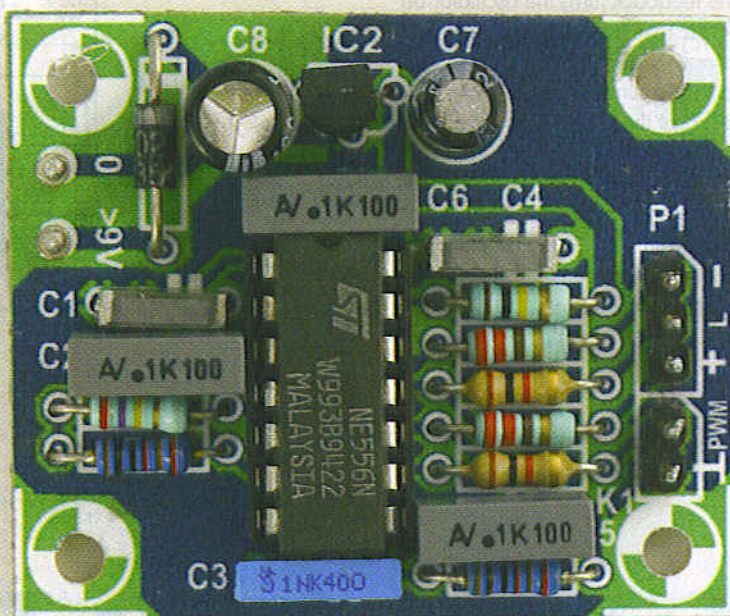

notes. All we need to mention is that the frequency equals

$$1.49 / ((R1+2R2) \times C1) \text{ [Hz]}$$

R2 has been kept small so that the frequency can be varied easily by adjusting the values of R1 and/or C1. The second timer works as a monostable multivibrator and is triggered by the differentiator

constructed using R3 and C3. The trigger input reacts to a rising edge. A low level at the trigger input forces the output of the timer low. R3 and C3 have therefore been added, to make the control range as large as possible. The pulse-width of the monostable timer is given by $1.1 \times R4 \times C4$ and in this case equals just over a millisecond. This is roughly half the period of IC1a. The pulse-width is varied

COMPONENTS LIST

Resistors:

R1 = 270kΩ
R2, R3 = 10kΩ
R4 = 100kΩ
R5, R8 = 1kΩ
R6, R7 = 220Ω
P1 = 2kΩ2, linear, mono

Capacitors:

C1, C4 = 10nF
C2, C5, C6 = 100nF
C3 = 1nF
C7 = 2μF2 63V radial
C8 = 100μF 25V radial

Semiconductors:

D1 = 1N4002
IC1 = NE556
IC2 = 78L15

Miscellaneous:

P1 = 3-way pinheader
K1 = 2-way pinheader

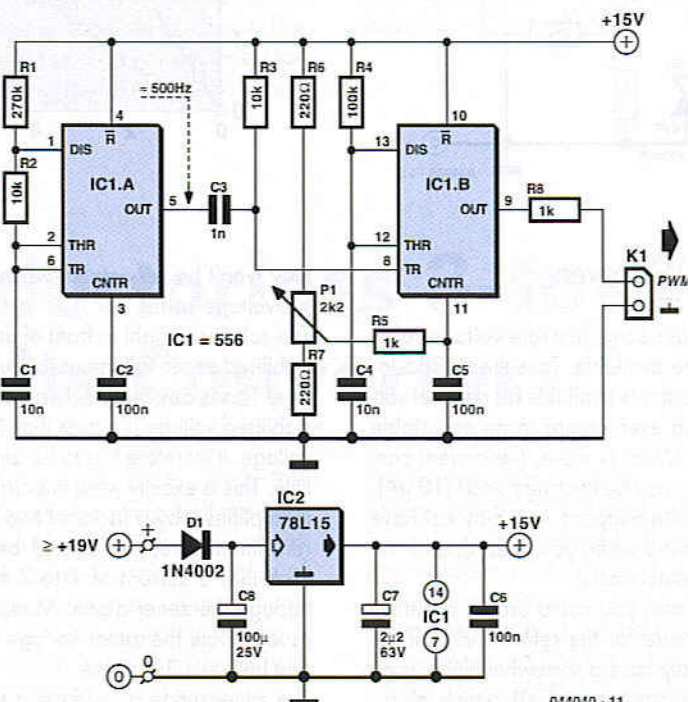

044040 - 11

using P1 to change the voltage on the CNTR input. This changes the voltage to the internal comparators of the timer and hence varies the time required to charge up C4.

The control range is also affected by the supply voltage; hence we've chosen 15 V

for this. The voltage range of P1 is limited by R6, R7 and R5. In this design the control voltage varies between 3.32 V and 12.55 V (the supply voltage of the prototype was 14.8 V). Only when the voltage reaches 3.51 V does the output become active, with a duty-cycle of 13.5 %. The

advantage of this initial 'quiet' range is that the lamp will be off.

R8 protects the output against short circuits. With the opto-coupler of the dimmer as load, the maximum current consumption of the circuit is about 30 mA.

(044040-1)

Xilinx JTAG Interface

064

Paul Goossens

In September 2002 we published a JTAG interface that was compatible with the programming software from Altera. Unfortunately, the software from Xilinx didn't work in combination with this interface. The interface published here is compatible with the software from Xilinx, so you can use it to program their range of CPLDs and FPGAs.

The circuit is very simple and consists of just two ICs and a handful of discrete components.

Connector K1 is connected to the PC using a 1:1 printer cable with a 25-way sub-D connector at each end. Connector K2 is connected to the JTAG interface of

Table 1. Pinout for K2

	FPGA	CPLD
1	Vdd	Vdd
2	GND	GND
3	CCLK	TCK
4	D/P	TDO
5	DIN	TDI
6	/PROG	TMS

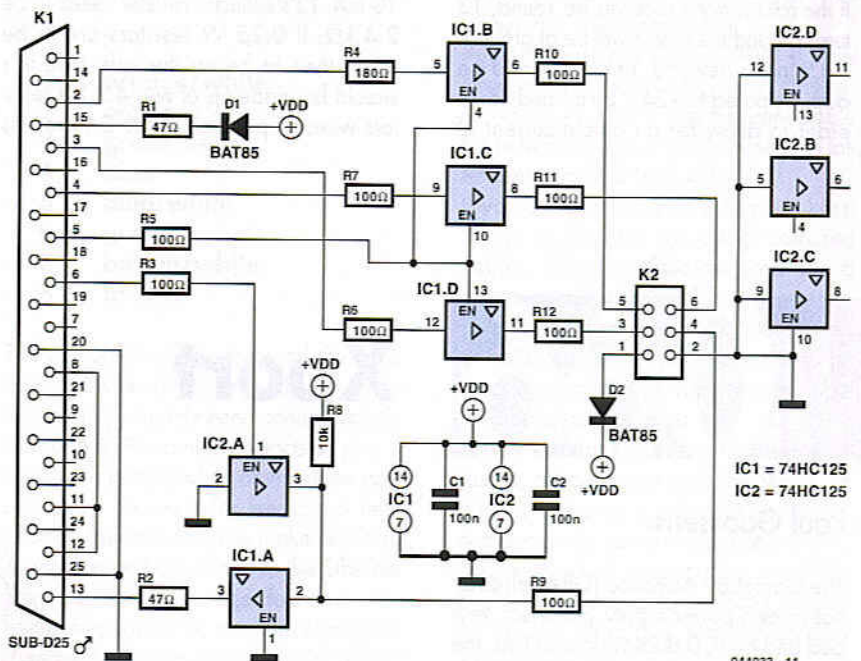

044033 - 11

the device being programmed. The pinout for connector K2 is shown in **Table 1**. If the device uses a different type of programming connector, K2 will have to be adapted accordingly.

The circuit can be easily built on a piece of prototyping board. Since there isn't

any real standard for the programming connector, it is very likely that the connections to K2 have to be modified; in that case, a ready-made PCB isn't very useful.

(044033-1)

Acoustic Sensor

065

Engelbert Göpfert

This acoustic sensor was originally developed for an industrial application (monitoring a siren), but will also find many

domestic applications. Note that the sensor is designed with safety of operation as the top priority: this means that if it fails then in the worst-case scenario it will not itself generate a false indication that a

sound is detected. Also, the sensor connections are protected against polarity reversal and short-circuits. The supply voltage of 24 V is suitable for industrial use, and the output of the sensor swings over

the supply voltage range.

The circuit consists of an electret microphone, an amplifier, attenuator, rectifier and a switching stage. MIC1 is supplied with a current of 1 mA by R9. T1 amplifies the signal, decoupled from the supply by C1, to about $1 V_{pp}$. R7 sets the collector current of T1 to a maximum of 0.5 mA. The operating point is set by feedback resistor R8. The sensitivity of the circuit can be adjusted using potentiometer P1 so that it does not respond to ambient noise levels. Diodes D1 and D2 rectify the signal and C4 provides smoothing. As soon as the voltage across C4 rises above 0.5 V, T2 turns on and the LED connected to the collector of the transistor lights. T3 inverts this signal.

If the microphone receives no sound, T3 turns on and the output will be at ground. If a signal is detected, T3 turns off and the output is pulled to +24 V by R4 and R5. In order to allow for an output current of

10 mA, T3's collector resistor needs to be 2.4 k Ω . If 0.25 W resistors are to be used, then to be on the safe side this should be made up of two 4.7 k Ω resistors wired in parallel. Diode D4 protects

the circuit from reverse polarity connection, and D3 protects the output from damage if it is inadvertently connected to the supply.

(030412-1)

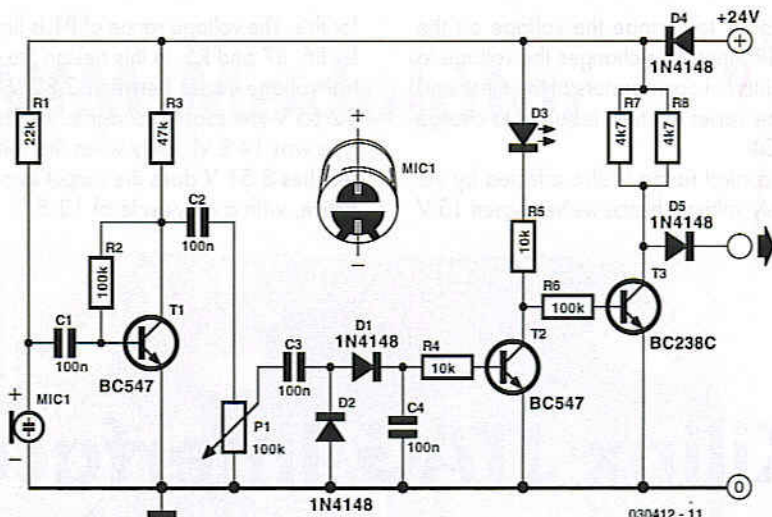

066

Xport

Paul Goossens

The Gameboy Advance (GBA) already has its own power supply, processor, keypad and an LCD display. In addition, the system bus is made available externally. All this is ideal as the basis for your own embedded system.

In the October 2000 issue of *Elektor Electronics* we published an expansion for the Gameboy: a digital oscilloscope. With the arrival of the Xport, made by Charmed Labs, the development of an embedded system based on the GBA has become a lot easier.

The Xport is a complete development system. Apart from the expansion board, the necessary software is also supplied.

The heart of the circuit on the expansion board is an FPGA made by Xilinx. Depending on the version you'll get an FPGA with either 50 K or 150 K gates on the board. Using the free development software from Xilinx, you can program your own designs into the FPGA.

The board also has a 4 Mbyte flash memory. This memory stores the program for the GBA as well as the configuration for the FPGA. Since the FPGA loses its configuration when power is removed, it must reload the configuration every time that it

is powered up. This takes place automatically thanks to a CPLD on the expansion board. Two versions of the Xport come with an extra 16 Mbyte of SDRAM. This memory can be used by both the processor and the FPGA.

Communication with the outside world is well provided for, with 64 I/O signals on board, in addition to the programming and debug connector!

As mentioned earlier, the system consists not only of hardware. The PC software

included is a C-compiler (GCC), complete with essential libraries, debugger and a programmer application.

On top of this, there is an operating system (eCos) and its bootloader. There are also various examples included (which should be in every good development kit), so you can start using the Xport soon after get your hands on it.

(040153-1)

Internet:

www.charmedlabs.com

Home Network for ADSL



Karel Walraven

The increased availability of fast ADSL Internet connections has made it more attractive to install a small RJ45 Ethernet network in the home. Not only can you exchange files between computers, you will also have fast Internet access for everybody! This does of course require an ADSL modem with a router. It's not possible to use a simple USB modem on its own.

For laptops we recommend wireless Ethernet connections. If you find the laying of cables too difficult or inconvenient you can also add wireless capabilities to 'ordinary' PCs. You should bear in mind that the range of wireless connections could sometimes be disappointing.

When a network is set up round a router you should use a star configuration for the cabling. This means that only a single PC is connected to each router socket. The connecting cable may have a maximum length of 90 m and usually terminates at a connection box. You should use a CAT5 cable with 8 conductors for this, which is suitable for speeds up to 100 Mb/s. The 8 conductors are arranged in 4 pairs, with each pair twisted along the length of the cable. It is extremely important that the wires of each pair are kept together and that they are kept twisted as much as possible. At the connector ends you should therefore make sure that the non-twisted sections of the cable are kept as short as possible, at most a few centimetres. Should you fail to do this you may find that the network won't operate at the full rated speed or possibly cause interference.

The wiring itself is very simple. Connect the plugs to the cables such that each pin connects to the corresponding pin at the other end. So pin 1 to 1, 2 to 2 and so on. This also applies to all patch leads between the connection boxes and PCs (or if you prefer, the cable can go directly to the PC, without a connection box). It is only when two computers are connected directly together without a router that a crossover cable is required.

The plugs are attached to the cable using a special crimping tool. It is also possible without the tool, using just a screwdriver, but this isn't easy and we don't recommend that you try it.

The wires in the cable have different colours and there are no official standards in Europe how you use them (EN50173). However, the colour code in

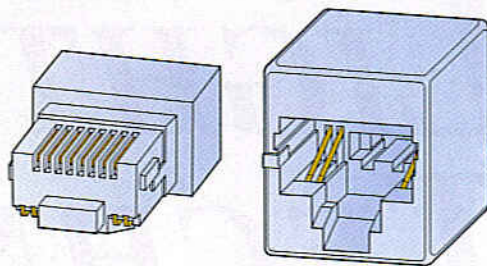

044007 - 11

the American T568B standard is often used:

- 1 orange/white
- 2 orange
- 3 green/white
- 4 blue
- 5 blue/white
- 6 green
- 7 brown/white
- 8 brown

The coloured/white wires and the solid coloured wires alternate nicely. For Ethernet cabling you only need connections 1, 2, 3 and 6. The central contacts on pins 4 and 5 are in the middle of the green pair and may be used for analogue telephones. You then have to make sure that 4 and 5 aren't connected to the Ethernet plugs because the voltages found on analogue telephone lines are high enough to damage an Ethernet card and/or router. Wires 4 and 5 should then be routed to

an RJ11 telephone socket. We don't recommend it, but it is possible.

It is also possible to pass ISDN signals through the same RJ45 plugs and cabling. In this case you can't use the same cable for both Ethernet and ISDN, since the latter uses pins 3/6 and 4/5.

If you use patch cables it helps to keep things organised by using coloured cables. Blue for Ethernet (red for a crossover cable), yellow for analogue telephones and green for ISDN. Sticky labels or coloured cable markers can also be used for identification when you can't get hold of coloured cables.

A new standard has recently been introduced, although you probably won't use it in the home for a while. Since around two years ago you can also use a GG45 connector, which is compatible with RJ45. This has 4 extra contacts and is suitable for speeds up to 600 Mb/s (Category 7/Class F).

(044007-1)

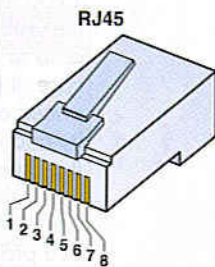
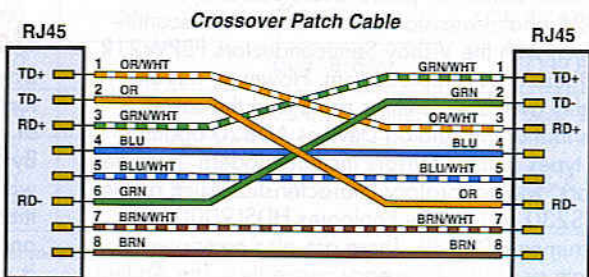
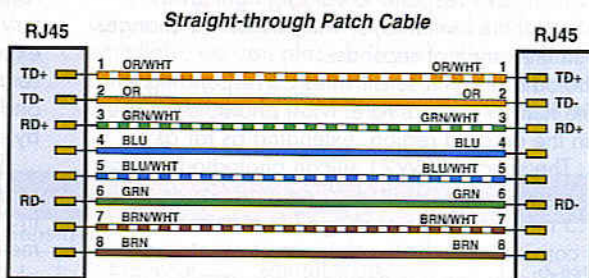

8-pin RJ45 Connector (8P8C)

044007 - 12

LIGHT SENSOR TECHNOLOGY

measuring daylight using LEDs

Light-sensitive sensors with characteristics similar to those of the human eye are most often implemented using photoresistors or special (and thus expensive) photosensors. Few people realise that normal LEDs can also be used as optical sensors that respond the same as the human eye.

Photodetectors for visible light are most often built using light-dependent resistors (LDRs), which are well-known components. Their spectral sensitivity is similar to that of the human eye. In the SMD age, their 'pros and cons' are their large package sizes, large tolerances, large temperature dependence and large sensor currents, besides which they are expensive and very slow. The speed at which LDRs respond to varying light levels is similar to that of the human eye, with resistance changes occurring in the range of seconds.

Fast photodiodes with sensitivities corresponding to those of the human eye are rare. Most photodiodes are sensitive in the infrared region, extending as far as 1100 nm. The special BPW21 silicon photodiode senses the visible region from 425 to 675 nm and has an active area of 7.5 mm², and it is packaged in a metal TO5 case. It is considered to be a reference element and priced accordingly, but it is accurate, has excellent linearity and is several orders of magnitude faster than an LDR ($t_{\text{on/off}} = 6 \mu\text{s}$ versus $t_{\text{off}} = 3 \text{s}$). It is often used as a sun-light reference sensor for photovoltaic power systems. The BPW21 phototransistor is classified as a discontinued product, with the Vishay Semiconductors PBPW21R being suggested as a replacement. However, it is still quite readily available. Still, its price is in the same league as that of the Analog Devices AD820 opamp.

Other types of light sensors include modern 'intelligent optosensors' with laboratory characteristics, such as the TAOS TCS230, Agilent Technologies HDSL9000 and Texas Instruments TSL230. There are also components that operate as light-to-frequency converters. The Agilent

Technologies type HSMF-C118 is a tricolour RGB LED in an SMD package. A summary of light sensors suitable for use with daylight is given in Table 1.

In the past, a variety of IC manufacturers have attempted to eliminate some of the drawbacks of these sensors and 'trim' them to act as converters with parameters suitable for use in the visible spectrum, with faster response times than passive LDR sensors. For laboratory applications, there are the highly accurate (and thus expensive) Tricolor Dreifeld type MCS3xx RGB colour sensors. They feature standardized spectral sensitivity and colour filtering, and they are planned to be followed by sensor arrays similar to CCD camera chips.

The monolithic OPT301 from Burr-Brown has a relative sensitivity of 80 % for yellow light and a peak response in the near-infrared region. It is only available in the hermetic TO99 metal package. It requires a symmetric supply voltage, which can be a disadvantage for modern applications. In addition, it requires an infrared filter if it is to be used as a daylight sensor.

Daylight

Daylight contains a high proportion of long-wave infrared radiation. We experience sunlight as warm, with the light at sunrise been sensed as cooler than the light at sunset. By contrast, moonlight has a high proportion of short-wave ultraviolet radiation. This is why we experience moonlight as cold. Our brain also 'sees' with our skin, and it's no accident that the spectral composition of light is referred to as its colour temperature. Our eyes have

also evolved accordingly, with the result that specific spectral shifts occur according to the intensity of the light, with colour sensitivity decreasing as light intensity decreases.

Incandescent light has a high proportion of infrared radiation, with a negligible amount of ultraviolet. Our eyes cannot sense long-wavelength light (IR or thermal radiation). Our skin cells are better equipped for this task. However, almost all silicon detectors have their peak sensitivities in the infrared region, so they are not suitable for detecting daylight or artificial light.

A normal LED, regardless of its colour, emits visible light, which after all is what it's designed to do. Its efficiency is very low, since most of the energy is converted into heat, although the amount of heat it generates is hardly significant due to its low power dissipation.

In contrast to all other artificial light sources, LEDs emit nearly monochromatic light with high colour saturation. In the CIE chart shown in **Figure 1**, all of the spectral regions for coloured LEDs are located close to the outer edge of the horseshoe-shaped line of maximum colour saturation. At the white point, by contrast, colour saturation approaches zero.

The CIE model

The CIE model is by no means perfect, since it cannot be used to explain colours such as brown or gold. It is thus not suitable for defining or accurately specifying our subjective perception of colour.

Colours outside the range of colour models, such as RGB, CMYK, LAB, and other models, only actually come into existence in our brains. The colour-sensitive cones and rods in our retinas have broadly overlapping spectral responses, which means they all contribute to every image. Their information is transmitted to the brain via chemical impulses in the nerve bundle. On their way to the brain, these impulses are 'premixed' by crosstalk between individual nerve cells, following which they are formed into a colour image in the brain. In this process, the receptors simply transmit impulses lacking any sort of colour information. Colours only come into existence in the brain as the result of combining these impulses and evaluating their mutual relationships.

A 'full-colour' image can be generated using a flat-panel display made from individually driven RGB LEDs.

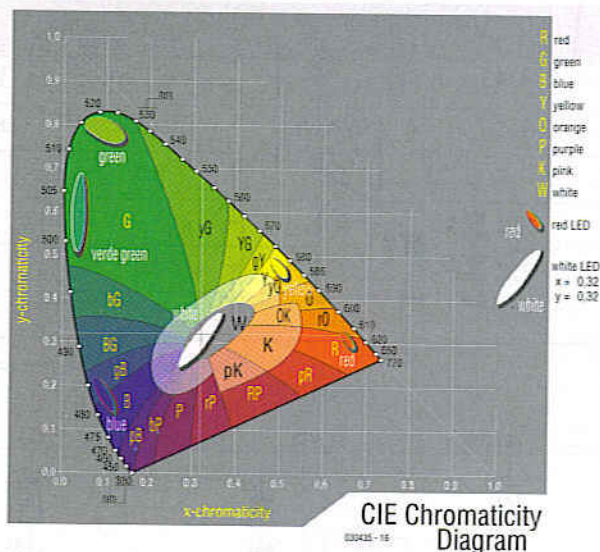

Figure 1. The colour gamut of the CIE standard chart, showing the narrowly demarcated LED regions.

However, the 'spot colours' (colours that cannot be directly generated using the primary colours) are still missing in such a display. On the other hand, the colour saturation of an LED display cannot be matched by any sort of high-quality printing, reflective LC display or CRT monitor, nor even by incandescent lamps with coloured filters. That's why arc lamps are used as light sources for film projectors in cinemas.

All of this demonstrates the virtues and vices of LEDs as colour sensors, taking the human eye as the reference. It is thus hardly surprising that high-quality colour sensors based on LEDs have only recently started to be developed. After all, the evolution of LEDs is still in its infancy, and it can be assumed that there are still many applications waiting to be developed.

Turning things around

Let's simply turn things around: instead of using an LED to emit light, we can place a 'bare' yellow or green LED in a field of light and connect a sensitive voltmeter to its leads. If we do so, we will measure a voltage that varies

Table 1. Integrated daylight sensors

Type	Topology	Sensitivity		Manufacturer	Case
		Range in nm	Maximum in nm		
BPW 21	P-N photodiode	420-675	565	Vishay	TO5 2-pin
OPT 101	Photodiode with OTA	280-1200	850	Burr-Brown	SO8 & DIP8 & SIP5
OPT 301	Photodiode with OTA	200-1150	750	Burr-Brown	TO99 8-pin
TSL 25x	Photodiode with OTA	300-1100	780	Texas Instruments	Plastic 3-pin
MCS3xx	3 RGB P-N photodiodes*	400-510 490-610 590-750	—	Jencolour	TO5 & SO8

* Truecolor Dreifeld RGB colour sensor ICs with dielectric interference filters and standard spectral sensitivity, with or without IR blocker.

Figure 2. The inputs of a CMOS opamp wired as an impedance converter have such high resistance that they do not place an excessive load on the photovoltaic output of the sensor LEDs.

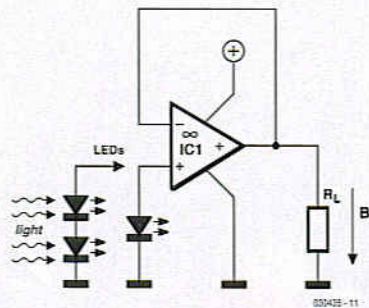
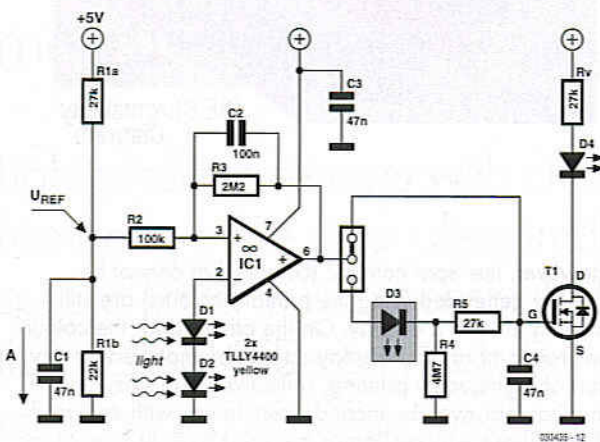

Figure 3. This daylight switch works with almost all types of JFET and CMOS opamps.



according to the intensity of the light falling on the LED.

Unfortunately, these measurements cannot be directly used for anything else, since the extremely small light-sensitive area and low efficiency of the LED mean that this voltage can only be loaded with an extremely small current (in the femtoampère range). Even the internal resistance of a DVM is significantly less than the source resistance of a LED operating in sensor mode.

The circuit diagram in **Figure 2** shows a LED acting as a sensor and connected to the non-inverting input of an opamp. This opamp is wired as an impedance converter and has an input impedance on the order of several teraohms ($10^{12} \Omega$), due to its simple JFET or CMOS inputs. It thus places almost no load on the voltage from the LED sensor. The LED sensor voltages listed in **Table 2** were obtained using this measurement circuit.

Here the designation 'impedance converter' is actually not entirely correct, since this is a transimpedance amplifier, which is a two-port network characterised by current, voltage and impedance conversion. In the circuit shown in **Figure 2**, the transimpedance amplifier is only wired as an impedance converter. However, this does not need to be discussed any further here.

Figure 3 shows an electronic switch that switches on the connected load R_L at dusk and switches it off again at dawn. The network formed by R_1 – R_3 provides a reference voltage $U_{REF} = 2.25 \text{ V}$ at the non-inverting input, with a measured hysteresis of approximately 250 mV. This threshold value is not critical; it is suitable for two low-current yellow LEDs connected in series.

With two LED sensors oriented in different directions, the threshold level is crossed relatively quickly during twilight. Resistors with ten-percent tolerance are adequate for this 'precision' circuit. Using two LEDs makes the circuit insensitive to artificial light falling on only one sensor, such as light from a streetlight or car headlights. The 'lag circuit' consisting of LED D_3 , R_4 , R_5 and C_4 also helps here. D_3 is enclosed in a length of heat-shrink tubing, which gives it significantly better blocking characteristics than a regular diode.

Opamp selection

In theory, a TLC271 (which has a single p-channel MOSFET input stage) is a suitable choice, since its input bias current is just as low as that of the AD820. In practice, however, it is inclined to oscillate at the switching point. This tendency to oscillate also cannot be eliminated with the TLC271, OPA132, AD8035, AD8510 and TLE2081 opamps. With an AD8065, AD820 or AD8610, a network composed of R_2 , R_3 and C_2 can be used to generate a hysteresis, which is necessary to provide jitter-free switching with 'creeping' twilight. The lag circuit is not necessary with the latter types of opamps.

A TL081 does not see the integration network as the source of a threshold potential, but only as a feedback network that sets the gain. In a circuit built according to **Figure 2**, a Schmitt-trigger circuit should thus be placed between the output of IC1 and LED D_3 . In any case, the TL081 does not oscillate all that wildly.

The high-precision OPA665 is fully overqualified (and correspondingly expensive) for the job of daylight sensing. It can be used to build a fast detector for arc lamps. However, it is designed to operate from a bipolar $\pm 5 \text{ V}$ supply.

The photo at the head of the article shows a prototyping board (EVM) from Texas Instruments that the author used to test the various types of opamps in the daylight sensor circuit. **Table 3** provides a summary of suitable operational amplifiers. Other types of opamps having bipolar input transistors or complementary MOSFETs are unsuitable, either because their input resistance is too low or because their input offset current is much too high. Such offset currents result from always-present differences in the gate currents of the complementary transistors in the input stage.

The switching point can be shifted to accommodate other light intensities or other types of LEDs by adjusting the values of R_{1a} and R_{1b} . When adjusting these values, it is best to short out the time-delay network (D_3 , R_4 and R_5). This time-delay network is a lag circuit with a switch-off delay of approximately 3 s. This may appear to be relatively short compared with the duration of twilight at our latitudes, but it is based on practical experience. Just bear in mind that for colour vision, our eyes have a dynamic range for light intensity of around 100 dB (from approximately 0.1 lux to 20,000 lux).

During twilight, the voltage across the LEDs increases or decreases markedly. It thus passes through the switching-point hysteresis band relatively quickly. For extremely slow changes in light intensity, a modern operational amplifier such as the AD8610 should be used, since it has practically stable switching behaviour and a small amount of light hysteresis. This may make it possible to omit the time delay circuit.

Table 2. Equivalent LED voltage for mean morning/evening twilight levels and a moonless night (Figure 1 output)

LED	Type	U _{BIAS} [V] with one LED		U _{BIAS} [V] with LEDs	
		Twilight	Dark	Twilight	Dark
Yellow	TLLY4400 (3 mm low-current)	1.1	0.8	2.2	1.0
Red	TLLR4400 (3 mm low-current)	1.0	- 1	2.0	- 1
Green	TLLG4400 (3 mm low-current)	1.2	0.8	2.4	1.4
Blue ³	LF-59EBGBC (5 mm RGB)	1.5	- 2	2.4	- 2

1: A red LED detects near-infrared radiation, so it cannot be used to measure night-time light.

2: Not measured.

3: Only one blue LED connected.

Table 3. A selection of suitable opamps with JFET input stages

Type	GBP in MHz	Offset in μ V	Input bias in pA	U _{CC} in V	I _{CC} in mA	U _{IN} max. in V	Manufacturer	Case	Tested?	Note(s)
AD8033	80	1000	1.5	+5 to 24	3.3	0 to +U _{CC} -3	Analog Dev.	SO 8 & SOT 23	yes	Shutdown
AD8065	145	400	2	+5 to 24	6.4	0 to +U _{CC} -3	Analog Dev.	SOT 23	yes	
AD820	1.8	100	2	+3 to 36	0.65	-0.2 to +U _{CC} -1	Analog Dev.	SO 8 & DIP 8	yes	
AD8610	25	85	2	+5 to 26	3.5	0 to +U _{CC} -3	Analog Dev.	SO 8 & MSOP8	yes	
AD8627	5	500	0.5	+5 to 26	0.75	0 to +U _{CC} -1	Analog Dev.	SO 8 & SC70	yes	
OPA132	8	250	5	+5 to 36	4	Rail-to-Rail (input and output)	Burr-Brown	SO 8 & DIP 8	yes	THD = 0.000.08%
TLE207 I	10	500	6	+4.5 to 36	1.7	0 to +U _{CC}	Texas Instr.	SO 8 & DIP 8	yes	Offset adj.
TLE208 I	10	1100	6	+4.5 to 36	1.7	0 to +U _{CC}	Texas Instr.	SO 8 & DIP 8	yes	Offset adj.
TL081C	3	3000	5	+4.5 to 16	1.4	0 to +U _{CC}	Texas Instr.	SO 8 & DIP 8	yes	Offset adj.
TLC271 C	0.09	1100	0.1	+3 to 16	1	-0.2 to +U _{CC} -1	Texas Instr.	SO 8 & DIP 8	yes	Offset adj.
OPA655	240	1000	-5	\pm 4.75 to 5.25	25	\pm 2.75	Burr-Brown	SO 8 & DIP 8	no	
INA121	-	200	4	\pm 2.25 to 18	0.45	-U _{CC} +2 to +U _{CC} -1	Burr-Brown	SO 8 & DIP 8	no	Precision InAmp

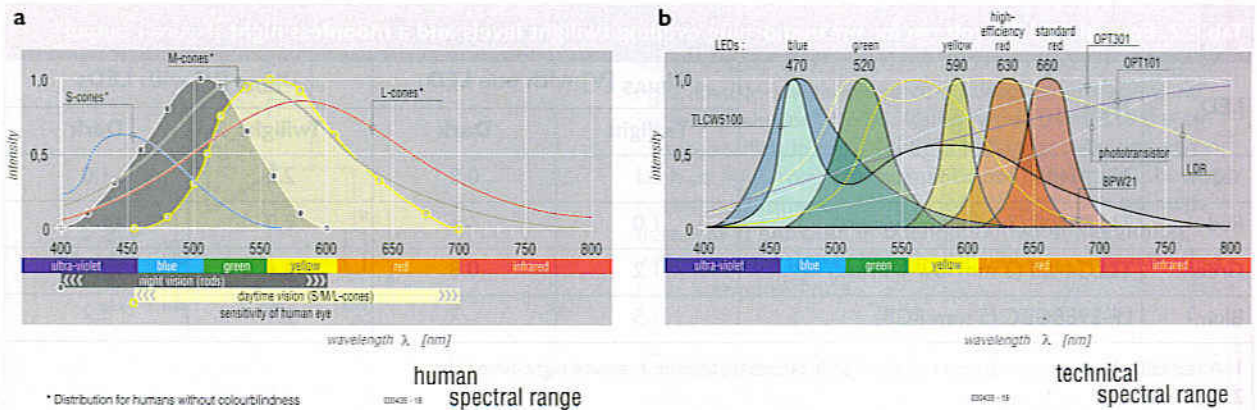

Figure 4. Comparison of human spectral ranges (a) and technological spectral ranges (b).

Light spectra and human vision

Figure 4 shows the daytime and night-time light sensitivities of the human eye, along with the spectra of a variety of electronic components. The spectral sensitivity of the eye changes with differing lighting levels. This is reasonable, since we can see not only bluish moonlight, whose spectrum is close to the UV region, but also yellowish sunlight, which is shifted toward the IR region.

Just as the retina adapts to different brightness levels, it also adapts to colours if they are observed for relatively long times. We sense a white sheet of paper as white, even if it is being illuminated by incandescent light, because our memory tells us the paper is white, although it is actually reflecting yellowish-red light.

Our eyes can also adjust to an enormous dynamic range of brightness, ranging from night vision to day vision. This is a range of 0.00001 to 1,000,000 cd/m^2 , which corresponds to a dynamic range of 220 dB. No artificial component can achieve this dynamic range. Perception of colour and contrast improves with increasing light intensity, but decreases again with very bright light. However, in the majority of this range of light intensity our eyes are predominantly sensitive in the black-and-white spectrum. In the colour region, our eyes have a dynamic range of 'only' 100 dB.

The human sense of colour is individual. There is no such thing as a green that is perceived the same by everybody, a neutral grey that is the same for everyone or a perfect white. All monitor calibrations are based on the subjective colour perception of the user in question. By contrast, it is certainly possible to standardise radiant sources relative to each other, such as the grey of a cloudy afternoon, the white of an incandescent lamp or the Sahara yellow of a car body, because they are technically measurable, adjustable and repeatable.

The retina, which covers the inside of the rear hemisphere of the eyeball, consists of a network of cone-shaped and rod-shaped sensor cells (receptors) that convert incident light into electrochemical substances (neuronal energy). The arrangement and relative numerical distribution of these receptors varies over the entire rear hemisphere of the eyeball. These factors vary relative to location on the surface of the retina, and they also vary from one person to the next.

Approximately 100 million rods are active for night

vision, and approximately six million cones are active for day vision. Just as multicoloured LEDs have narrow bandwidths and different radiation intensities, the sensory cells for brightness, contrast and colour have complex, differentiated sensitivities, but they have relatively large bandwidths. There are three types of cones, which are sensitive to daylight. They respond to short-wavelength, medium-wavelength and long-wavelength light and are thus called S, M and L cones, respectively. In contrast to the nearly monochromatic colour emission characteristics of LEDs, the cones have broadly overlapping response curves.

Colours in the blue region appear to be darker than colours in the green and red regions because the short-wavelength sensor cells respond more weakly to stimuli. Due to the large overlap in the spectral sensitivities of the S, M and L cones, a person with 'normal' vision has especially high spectral sensitivity at 555 nm (green) for day vision (photopic vision). The BPW light sensor is matched to this peak sensitivity, as are light signalling systems used for railways and marine transport. By contrast, modern traffic-light systems now take people with non-standard colour perception into account and emit green signal light with a large blue component.

The lenses of our eyes absorb ultraviolet light. People who develop cataracts can have the natural corneal lens replaced by an artificial plastic lens. Such people can then see UV light in a range extending to below 300 nm, thanks to their S cones. Insects are especially sensitive to UV light. For people with normal vision, the maximum spectral sensitivity for night vision (scotopic vision) is at 507 nm.

During data transmission from the sensory cells to the brain, there is crosstalk between neighbouring cell groups, not only in the retina but also in the optic nerves and in the brain. A virtual image only comes into existence after these nerve impulses arrive in the brain, where they are processed with reference to information already stored in the brain and converted into an image. The eye is only the measurement sensor for this process, and the actual sensory cells are 'blind' to colours and shapes. They simply convert light energy into electrochemical stimuli, which contain neither colour data nor image data. This is comparable to a graphic processor card with its three RGB lines to a monitor. Here only voltages are transmitted, not colour data or image data.

In a certain sense, the eye digitally decomposes the

photorealistic image impinging on the individual receptor cells via the pupil and lens. Due to the crosstalk between neighbouring receptors, optical nerves and brain cells, what we see is again a non-pixelated, photorealistic image without any sort of rasterization, moiré effects or colour fringes (such as are generated by a monitor and are well known in printing technology, since monitors and paper simply don't have brains). This means that a colour stimulus in the brain only arises from combining the information from all of the receptors and optic nerves.

Colour is not in the light and not in the eye, but in the brain.

Isaac Newton

These complex chemical and electrical conversions and transfers make standardisation impossible, especially because the levels of endogenous substances in the body can change colour perception. This occurs with vitamin deficiencies or with emissions of endogenous substances, which in extreme cases can lead to a blackout, in which the brain sees white increasingly strongly, colours become increasingly washed out and grey tones become brighter. (Of course, here we're not referring to the black-outs of certain well-known politicians!)

However, colour by itself is not a predominant consideration in the brain. This becomes evident if we attempt (in vain) to determine the distance to a light source. We may know the distance to a star in the night sky, but we estimate the distance to a lamp using its surroundings. Consequently, the brain needs to know not only the colour emission characteristics of an object, but also its structure and the nature of its surface (relative to stored experience), in order to generate an image using the total colour information. In the overall process, the brain also evaluates other impulses, such as may come from the senses of touch, taste, smell and hearing — and from the second eye.

Approximately 8–10 percent of all European men and 0.5–1 percent of European women have hereditary reduced sensitivity to red and/or green. The normal ratio of the sensitivities of the three photopic S, M and L cones is 10 % blue, 48 % green and 42 % red. With a chromatic visual deficiency, the three types of cones have a different relative distribution (such as a green deficiency with a distribution of 30 % blue, 30 % green and 40 % red). Some colour-blind people can still properly distinguish green from red, others do not see any difference between red and green, and yet others have a chromatic deficiency only in the central, acute vision region of the eye.

The cone distribution differs from person to person, and it also varies over the total surface of the retina. Red/green differentiation decreases steadily with increasing distance from the central acute vision region (toward the outer edge of the hemispheric rear surface of the eye).

Total colour blindness is very rare and occurs in only 0.003 percent of the population. There is also a yellow/blue form of colour blindness. Colour blindness is a hereditary deficiency that does not change with age, and it cannot arise during the course of a person's life, since it is inherited.

The 'normal' red/green distribution is relative to Central Europe and originates from the ancient times of hunters and gatherers, when it was vital to survival to be able to gather red berries from beneath green leaves or follow blood traces in the forest. Strictly speaking, our

normal condition amounts to a hypersensitivity for red/green contrast perception, which is not necessary in other types of landscape such as deserts or polar regions. Colour blindness as a visual deficiency is thus relative to the visual capacity of a majority of the population in a particular landscape.

For persons in professions such as web design and equipment design, who deal with the visual aspects of devices, it is certainly important to pay attention to this phenomenon, since men and women with various forms of colour blindness form a considerable proportion of our population. What is white? What is blue? What is a neutral grey? These considerations influence phenomena such as simultaneous contrast (apparent colour tinting of an area seen against a background), colour stereoscopy (which causes red to appear to be closer and blue further away), illegibility of red text on a green background, and other types of chromatic displacement. After all, our lives and our moods depend on colour.

The technology used in our electronic media is similar to the biology of our eyes. However, no-one has yet succeeded in using technical resources to transform the information from our nerves and brain into a photograph.

Summary

Light sensors using standard LEDs as sensors connected to opamps with JFET inputs or simple MOSFET input stages are certainly worth consideration. In such a configuration, various types of IC topologies exhibit different types of oscillatory behaviour during switching.

With relatively old types of ICs, the frequency of oscillation at the switching point can only be defined with integrating feedback using C2 and R3. By contrast, with more recent types of opamps an RC network at the non-inverting input produces better-defined switching behaviour with additional hysteresis over the range of light intensity. This depends on the integrated compensation system of the IC, which is not externally visible.

For a simple light sensor built according to Figure 2 and having a time delay of 3 seconds, all of the listed types of opamps are suitable. Their mutual differences are essentially smaller than the variations due to the passive external components. Altogether, this yields an accurate, economical SMD design using fewer components and having a smaller area than with a discrete BF245 JFET, a standard opamp and a trimpot.

(030435-1)

Free Downloads

The author's extensive documentation for this article, including reference sources, literature references and Web references, can be downloaded from the Elektor Electronics website at no charge under download number 030435-12. All available downloads can be found at www.elektor-electronics.co.uk/dl/dl.htm.

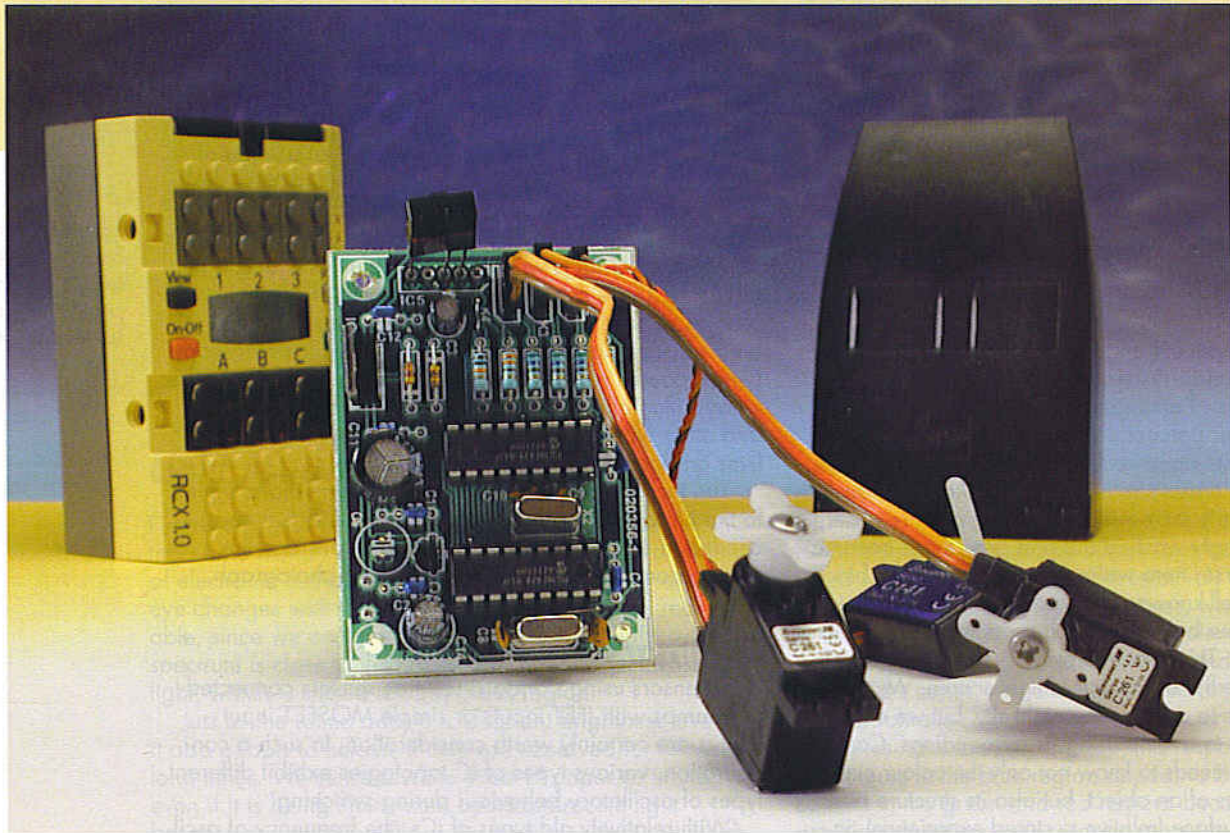

IR Servo Motor Interface for RCX

LEGO RCX-compatible infrared remote control for servos

One of the few features lacking from the LEGO Mindstorms system is an accurate positional drive. This has prompted the author to develop this interface circuit, which can control up to three servos of the type used in radio-controlled models via the IR-interface of the RCX brick.

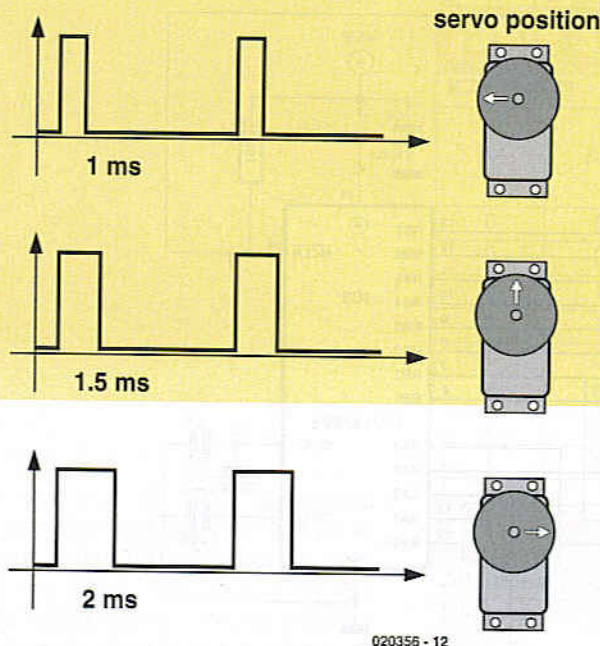

Figure 1. Driving a servo using a rectangular waveform whose pulse width determines the servo's position.

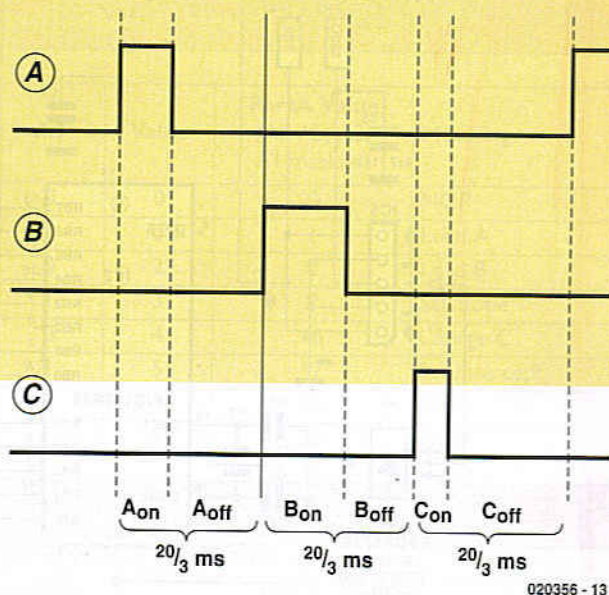

Figure 2. Timing diagram showing the output signals of the PIC to control three servos.

The three different types of LEGO Technic 9 V motors are more than adequate for most robotics projects. However, when accurate angular positioning is required, one can quickly become frustrated by the amount of play in the gears and start looking for a better solution.

The servos used in radio-controlled models offer more precision. Of course, we will not only have to deal with mechanical interface problems of joining to other LEGO bricks: we will also have to operate under control of the RCX, which is a little trickier. The RCX brick is the main control element in the LEGO Mindstorms system. It consists of a microcontroller built into a large, bright yellow, LEGO brick.

Ralph Hempel, the creator of pbForth, has, along with Andreas Peter, developed various add-on circuits that allow the RCX to be used with two servo motors. Descriptions of the circuits are available on the Internet: see references [1] and [2]. Hempel has provided special program commands in pbForth to drive his circuit, namely SERVO_INIT and SERVO_SET [3].

The circuit presented here will allow you to control up to three servos simultaneously with the RCX standard version 2.0 firmware, using the IR interface on the RCX brick.

Servo control

Servos for radio-controlled models use a form of pulse-width modulation (PWM). The control signal is a rectangular waveform with a frequency of about 50 Hz. The precise frequency is not critical: it need only lie somewhere in the range 30 Hz to 60 Hz. The information is carried only in the width of the rectangular pulse, which is allowed to vary between 1 ms and 2 ms. As Figure 1 shows, the servo is in its mid-position when the pulse width is 1.5 ms. Inside the servo there is a potentiometer attached to the output drive shaft. This gives the electronics in the servo the necessary angle feedback information. Because of the potentiometer end-stops, the servo should never be overdriven, or it will be permanently damaged. This can happen if the pulse width is outside the permitted range.

In order to drive three servos at the same time, three rectangular waveforms need to be generated whose pulse widths can be adjusted independently of one another. As can be seen from the circuit diagram in Figure 3, a microcontroller type PIC16F628 (IC3) generates these signals. The program in the PIC is organised in such a way that the three control pulses are produced one after another in sequence at an overall rate of 50 Hz. Thus we have:

$$A_{on} + A_{off} + B_{on} + B_{off} + C_{on} + C_{off} = 1/50 \text{ s} = 20 \text{ ms}$$

We are given A_{on} , B_{on} and C_{on} , the desired pulse widths. The 20 ms total time available is divided into three equal parts, giving:

$$A_{off} = 20/3 \text{ ms} - A_{on}; B_{off} = 20/3 \text{ ms} - B_{on}; C_{off} = 20/3 \text{ ms} - C_{on}$$

The behaviour is illustrated in the diagram in Figure 2. The pulse generator program operates as follows (in much-simplified pseudocode):

```
Label_1
  OutA on
  Wait A_on
  OutA off
  Wait A_off

  OutB on
  Wait B_on
  OutB off
  Wait B_off

  OutC on
  Wait C_on
  OutC off
  Wait C_off

  Goto Label_1
```

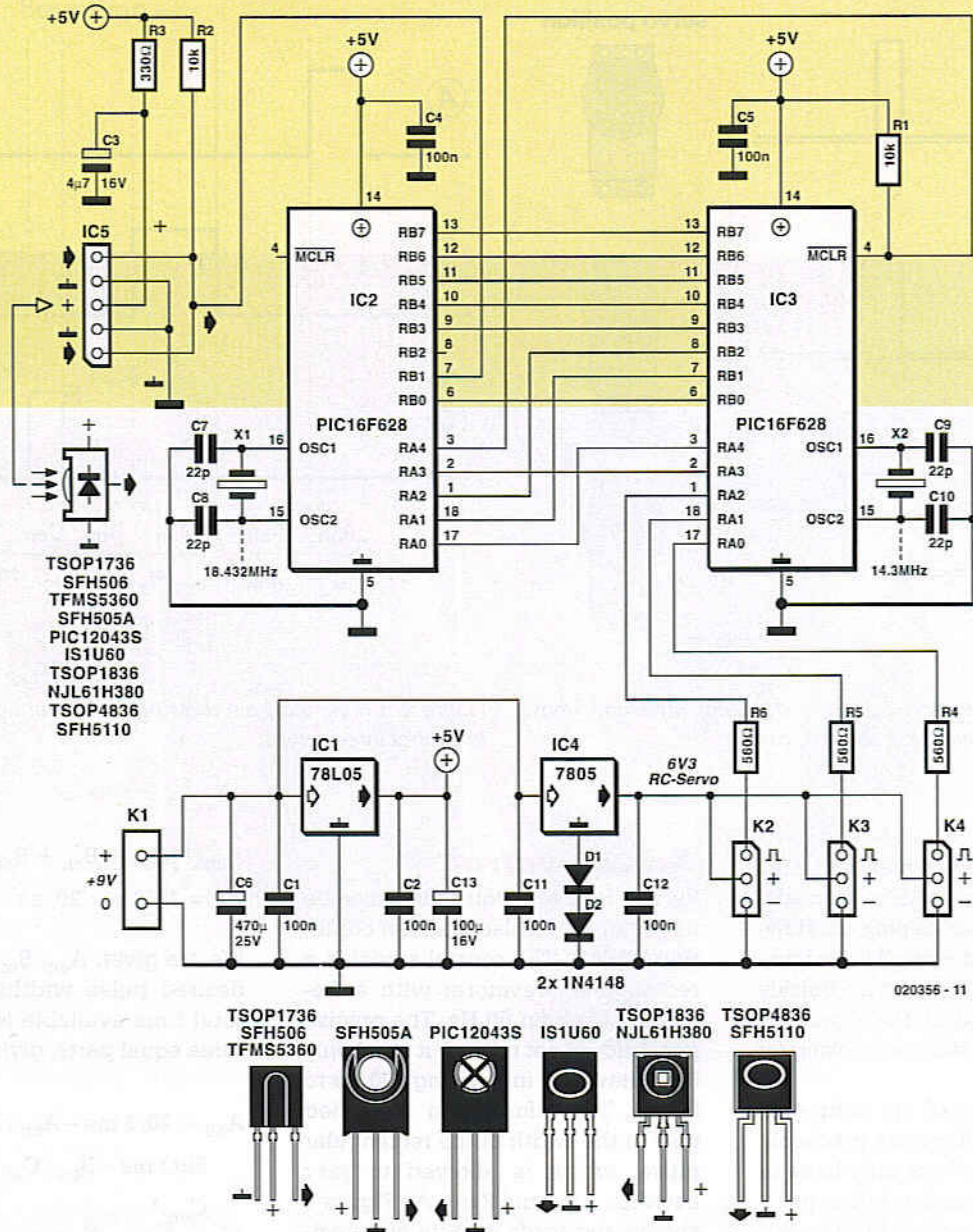



Figure 3. There are three main parts to the circuit: the dual regulated power supply (IC1 and IC4), the IR receiver (TSOP1738 and IC2), and the pulse generator (IC3).

Interface Circuit

The circuit in **Figure 3** is designed to operate from a separate 9 V battery supply. The two voltage regulator circuits using separate voltage regulator ICs (IC1 and IC2) mean that the main supply voltage does not drop when the servos move, ensuring trouble-free operation. If all three motors are moving at the same time, the current draw can be up to around 500 mA. The interface should therefore under no circumstances be connected to an RCX output, which is not suitable for such currents. Note also the rather odd use of diodes D1 and D2. A voltage of about 0.65 V is dropped across each diode, which shifts the voltage at the

ground pin of the 7805 by 1.3 V. This increases the output voltage of regulator IC4 to 6.3 V, which is the ideal voltage for the servos.

The actual IR servo motor controller circuit consists of IR receiver IC5 and two type PIC16F628 microcontrollers connected to one another. The first microcontroller (IC2) converts the serial data obtained from the IR receiver to parallel, and sends it on to the second microcontroller (IC3). This is done using an 8-bit data bus and three control signals. The maximum resolution achievable is one part in 256. The 1 ms time period is divided into 255 steps which, depending on the characteristics of the servo, gives an angular

resolution of less than 1°. On some types of servo motor this resolution is greater than the so-called 'dead band' (typically 5 µs), and so it is possible that the servo motor will not react to a change of just one unit in the control value. (The 'dead band' is a necessary feature of servo motors to ensure that while the motor is turning, the incoming control signal and the internal reference signal can be aligned as quickly as possible, but without having the rotor oscillate about the target position.)

The second PIC (IC3) operates at a clock frequency of 14.3 MHz, a value chosen on the basis of the relationship between the servo control pulse

widths and the PIC instruction cycles. The clock period is 69.9 ns: as in the earlier PIC16F84 device, most of the RISC instructions of the PIC16F628 are executed in 4 clocks, and this is also the rate at which the timer increments. An instruction therefore takes 279.9 ns. The program in IC3 uses the 16-bit timer (TMR1), and the shortest servo pulse of 1 ms corresponds to 3575 increments of TMR1. This value is also the one used on initialisation. There follows an 'off' period of $(20/3 - 1)$ ms, which corresponds to 20258 increments. The pulse length in PIC cycles is calculated as follows:

$t = a * x + b$, where:

$0 < x \leq 255$
(0 is a reserved value)

$a = (7150 - 3575) / (255 - 1)$
 $= 14.0$ (slope)

$b = 3575$ (intercept)

Now we can see why the particular clock frequency of IC3 was chosen: the quotient $3575/254$ is approximately an integer. The program in the PIC has the facility to use slope and intercept values different from those given above in order to allow the servos to be trimmed. There are certain limitations in the communications protocol which mean that we can only send 8-bit values: this means that the slope can only be set to integer values, and the intercept can only be adjusted in steps of 20.

Data transfer

Parallel data transfer between IC2 and IC3 takes place in two stages. Two microcontrollers are used because there are several time-critical operations to be carried out. First,

Table 1 Control lines truth table

IC2 (UART)					
A4	A3	A0	Value	PortA Value (A7-A5, A2, A1 masked)	Meaning
0	0	0	0	0	NOP
0	0	1	1	1	Load A
0	1	0	2	8	Load B
0	1	1	3	9	Set Slope
1	0	0	4	16	Charge C
1	0	1	5	17	Set Intercept
1	1	0	6	24	NOP
1	1	1	7	25	Reset

Table 2

Additional LEGO protocol data to monitor transmission	
Data header (for all opcodes)	hex 55 FF 00
Opcode	0x14 (=d20)
Opcode Complement	0xFF-0x14 = 0xEB
Dummy	0x00
Dummy Complement	0xFF
Dummy	0x00
Dummy Complement	0xFF
Instruction	n
Instruction Complement	not(n)
Data	x
Data Complement	not(x)
Checksum	s
Checksum Complement	not(s)

Table 3

ROBOLAB Command overview (Device Instruction Set)		
Instruction	Number	Command
1 (1)	0	Select channel A
2 (8)	0	Select channel B
4 (16)	0	Select channel C
1 (1)	1..255	Charge A
2 (8)	1..255	Charge B
4 (16)	1..255	Charge C
3 (9)	0..255	Set slope of selected channel (default 14)
5 (17)	0..5100 (0..255)	Set intercept (DIV 20) of selected channel (default 3575)
7 (25)	x	Reset all slope and intercept values to default

the UART (Universal Asynchronous Receiver and Transmitter) must always be ready to receive data, since the interface does not know when the next IR command will arrive. Second, the UART must manage reception of data according to the LEGO protocol (opcode 0x14), which uses a block size of 15 bytes at 2400 baud (using one start bit, 8 data bits, a parity bit and one stop bit): this gives a total transmission time of about 70 ms per command. Finally, three independent stable

pulse-width modulated signals must be generated according to the incoming commands, and the jitter in these pulses must be kept within the dead band of the servo. The effort involved in trying to integrate all these functions into a single reliable program in one PIC makes the price of a second PIC16F628 look insignificant.

Pins RB1 and RB2 of IC2 are configured for use with the UART and so are not available to form part of the parallel data bus. RA1 and RA2 are

COMPONENTS LIST

Resistors:

R1,R2 = 10k Ω
R3 = 330 Ω
R4,R5,R6 = 560 Ω

Capacitors:

C1,C2,C4,C5,C11,C12 = 100nF
C3 = 4 μ F 7 16V radial
C6 = 470 μ F 16V radial
C7-C10 = 22pF
C13 = 100 μ F 16V radial

Semiconductors:

D1,D2 = 1N4148
IC1 = 78L05
IC2,IC3 = PIC16F628, programmed,
order codes 020356-41 (IC2),
020356-42 (IC3)
IC4 = 7805
IC5 = TSOP1738 (see text)

Miscellaneous:

K1 = 9-V battery (see text)

K2,K3,K4 = 3-way pinheader
X1 = 18.432MHz quartz crystal
X2 = 14.3MHz quartz crystal (see text)
PCB, order code 020356-1 (see Readers
Services page)
Disk, order code 020356-11 or Free
Download

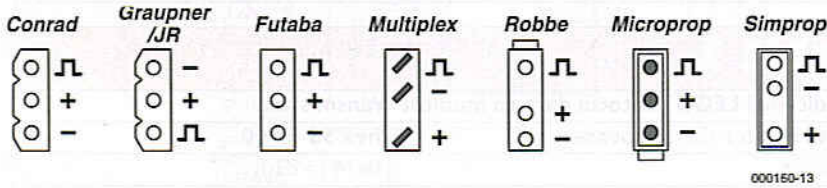

Figure 5. Pinouts of various commonly found radio control servos.

used instead. This arrangement requires the use of at least one control signal, since the two ports of IC2 cannot be updated simultaneously. Without a control signal, IC3 could read erroneous values between the updates of the ports. In looking at the control signals, note that RA4 of IC2 is an open-drain output and therefore requires a 1 k Ω pull-up resistor (R1).

The two ICs are configured so that the internal MCLR signal is pulled to V_{DD}, thus freeing up the pin to be used as the RA5 input on IC3. Table 1 shows the values on the control signal bus and what they signify.

RCX UART

Using the LEGO Mindstorms SDK2 [4] and version 2.0 of the firmware, the user has access to the transmit channel of the RCX UART. This opens the door to a new world of robotics projects. For example, an RCX can program another RCX, or several RCX bricks can jointly process sensor and variable data, simply by obeying the LEGO UART protocol and sending the right opcodes. Be warned, however, that communication will be with all RCX bricks in range of the IR commands. This can, according to the SDK, have 'catastrophic' results. For good reasons we have chosen the opcode 0x14 ('SETVAR' or 'SETV') for use here. This command is no longer

used in ROBOLAB 2.5, since a universal 'Set' command was introduced in version 2.0 of the firmware, which allows — depending on the configuration — both sensor values and other variables to be set.

According to the datasheet the full command is as follows:

SETVAR: 0x14 variable, source, number (LO), number (HI)

(Reply 0xE3. Note that once the receiving RCX brick has verified the opcode it sends a confirmation of reception. In our case this is not relevant, but a short pause should be inserted between consecutive opcode transmissions to avoid IR interference.)

We slightly modify this command:

0x14 0 (dummy), 0 (dummy), instruction, data
(The RCXs involved will unfortunately lose the use of control variable 0.)

The LEGO protocol employs several additional data bytes to confirm correct data transmission, as shown in Table 2. The receiver can check the complement bytes and compute the checksum over the received bytes: this can be compared with the received checksum. Overall, this gives a good check on the communication quality. Although the RCX carries out a parity check, it is not essential in the program in IC2 and

in any case the 16F628 UART does not provide an automatic parity check facility. The author used the low-cost TSOP1738 from Vishay-Telefunken as IR receiver and demodulator. LEGO IR transmissions are at 2400 baud and use a carrier of 38 kHz. This sensitive IR receiver gives a range of up to 10 m, when the RCX is configured for long-distance IR communications.

Table 3 gives an overview of the instructions used in the ROBOLAB program, with actual values sent given in brackets. As already mentioned, care should be exercised when trimming the servo parameters: in order to avoid overdriving the servo, with possible consequent damage, make adjustments only in small steps.

Construction

The printed circuit board (Figure 4) is small but easy to populate, and so construction should not present any problems. Care should be taken with the wire links: they are the price that must be paid for using a single-sided circuit board. There are six wire links in total, of which three are under the ICs, one being under IC2 and two under IC3. These wire links are best made with insulated wire on the underside of the board. Alternatively the links can be made on the component side using thin copper wire, passing under the ICs (or their sockets). In any case the wire links should be fitted first, followed by the passive components, and finally the active components. As always, take care with the soldering and pay attention to the component values, the polarity of the electrolytic capacitors and diodes, and the orientation of the ICs. The heatsink for the voltage regulator IC4 is mounted just off the edge of the board.

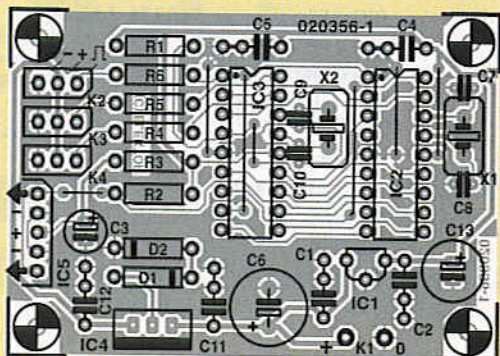

Figure 4. The single-sided circuit board is compact: note the wire links!

The 9 V battery is connected to the terminal pins marked K1. The current consumption of the circuit chiefly depends on the number and consumption of the servos. If space permits, it is best to use a battery made up from six AA-size cells: a 9 V PP3-type battery will have a much shorter life, perhaps by a factor of between five and ten.

IR receiver IC5 need not necessarily be soldered directly to the printed circuit board. It can be mounted remotely using a three-core cable running from the points on the board where IC5 would be located. Other IR receiver devices with similar characteristics can be substituted for the Vishay-Telefunken TSOP1738 specified in the parts list. Some of the alternatives available are shown in the circuit diagram (Figure 4) along with their pinouts. All the ICs have three pins, but on the printed circuit board five holes are provided for IC5, arranged so as to allow any of the suggested ICs to be directly soldered in (or wired) using three adjacent holes.

There is also an alternative to the 14.3 MHz crystal X2. If a crystal with this frequency is not available, a more readily-available 16 MHz part can be used instead. Ordinary radio control servos have no difficulty in coping with the effect of this change.

The three servos are connected to the headers at K2, K3 and K4. Again, attention must be paid to the pinout, and the various manufacturers of servos use different plugs on the end of the connection cable. The most frequently encountered arrangements are shown in Figure 5.

Operation

The servo driver interface can be controlled using ROBO LAB 2.5 with RCX firmware version 2.0, using the LEGO

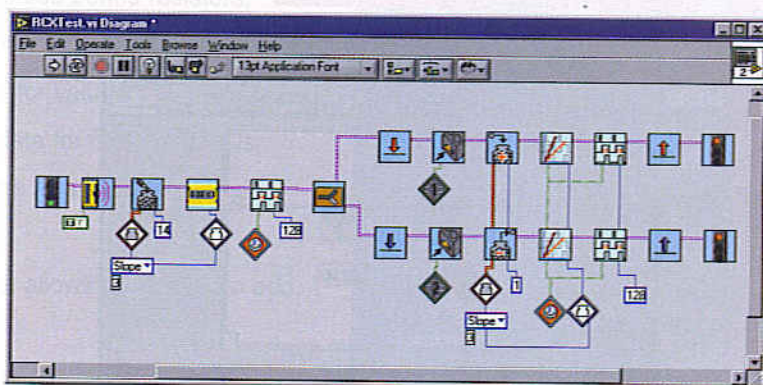

Figure 6. One of the RCX programs available for download from www.elektor-electronics.co.uk. The touch sensors can be used to adjust the servo's position.

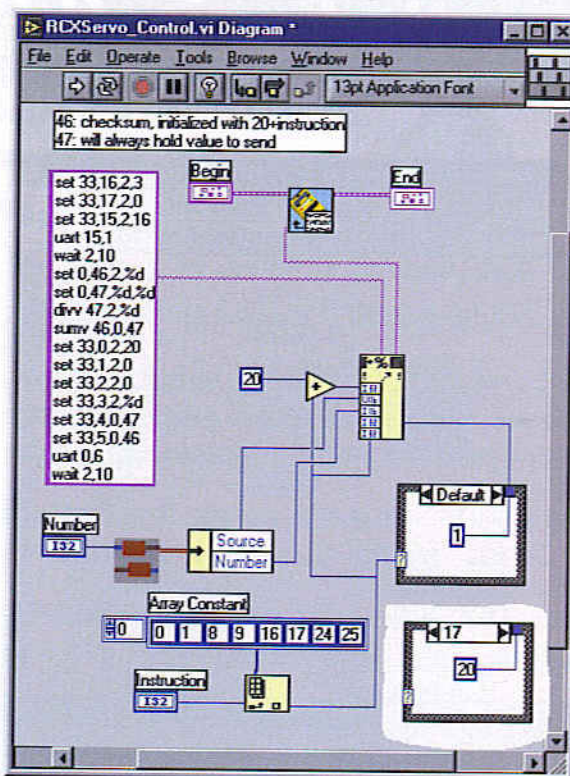

Figure 7. The heart of the RCX program: driving the RCX UART transmitter.

Web references

- [1] www.inchlab.net/2servo_interface.htm
- [2] <http://mindstorms.lego.com/sdk2/default.asp>
- [3] Dave Baum, Michael Gasperi, Ralph Hempel, Luis Villa: 'Extreme Mindstorms, An Advanced Guide to LEGO Mindstorms', p. 313.
- [4] <http://www.ceeo.tufts.edu/robola->

batceeo/Resources/documentation/
LEGOMindStormsSDK.zip

Free Downloads

PCB layout in PDF format. File number:
020356-1.zip

RCX program to drive the servos;
source and object code for the two

PICs. File number **020356-11.zip**
www.elektor-electronics.co.uk/dl/dl.htm, select month of publication.

Author's full documentation including pictures, programs, source and object code and instructions: http://www.convict.lu/IR_Servo_control.zip

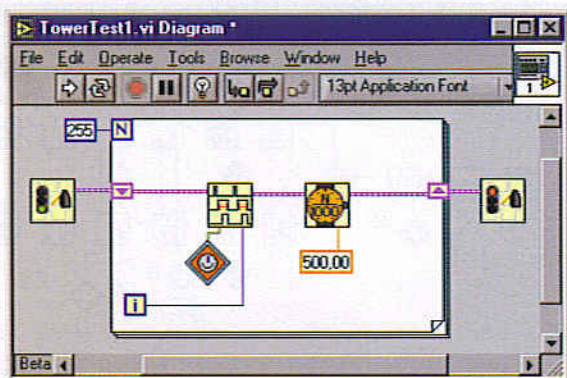

Figure 8. This simple program runs on the PC and controls the servos via the LEGO tower.

tower (RS232 or USB version), or from the RCX itself. Various programs are available for download (see the text box for addresses), of which we only have space here for a brief description.

Figure 6 shows a simple downloadable program with two parallel tasks. In this example the RCX increases or decreases the angular

position of the red servo, starting at its mid-position, according to which touch sensor is pressed. The colours red, blue and yellow follow the usual ROBOLAB colour coding convention. The second program icon puts the RCX into long-distance IR communications mode, and the display shows the current

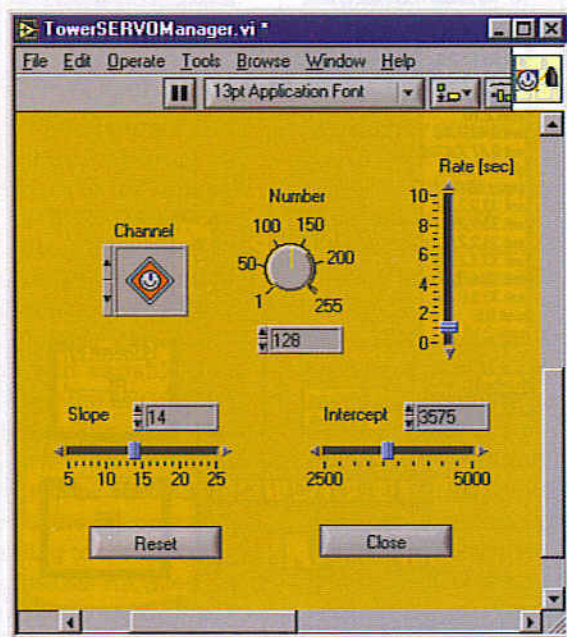

Figure 9. The easy-to-use front panel of the RCServo Manager.

slope value. The intercept value can also be trimmed in a similar fashion. Changing the slope increases or reduces the total range of motion of the servo, while changing the intercept only affects the zero position.

As usual in ROBOLAB/LabVIEW, entire program segments can be collected together and represented graphically by a single new icon, making it possible to take a high-level view of even the most complex programs. Figure 7 shows the heart of the RCX program: driving the RCX UART transmitter. Further information on the use of the UART can be found in the LEGO Mindstorms SDK [4].

The simple program in Figure 8 runs on the PC. The red servo motor turns slowly over its entire operating range. Note the use of a LabVIEW FOR loop with a shift register. Data leaving the main box on the right-hand side are stored in the shift register at the end of each iteration, and recirculated. This makes it very easy, for example, to check the program for any errors. The two icons outside the main box are responsible for tasks including initialising and shutting down communications with the LEGO tower. The program looks for the tower connection configured in ROBOLAB. The normal ROBOLAB RCX direct mode cannot be used, since the program would then wait forever for an acknowledgement signal from the RCX: in our case transmissions are in one direction only.

Finally, Figure 9 shows the front panel of the RCServo Manager program, which is very easy to use. Both slope and intercept can be trimmed, and the tower only transmits when a value is changed. If a value is changed continuously, the value of RATE determines the transmission frequency.

(020356-1)

ECD (Edition 2)

Elektor's Components Database

The program package consists of four databanks covering ICs, transistors, diodes and optocouplers. A further nine applications cover the calculation of, for example, zener diode series resistors, voltage regulators, voltage dividers and AMVs. A colour band decoder is included for determining resistor and inductor values.

The ECD gives you easy access to design data for over 5,700 ICs, more than 35,000 transistors, FETs, thyristors and triacs, just under 25,000 diodes and 1,800 optocouplers.

All databank applications are fully interactive, allowing the user to add, edit and complete component data.

This CD-ROM (Windows XP compatible) is a must-have for all electronics enthusiasts.

RRP £12.95
(US\$ 22.90)

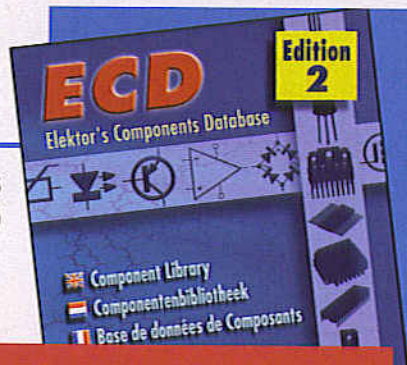

Now extended with even more ICs, transistors, FETs, thyristors and triacs!

Order now using the Order Form in the Readers Services section in this issue.

Elektor Electronics (Publishing)
P.O. Box 190
Tunbridge Wells TN5 7WY England
Telephone +44 (0) 1580 200 657
Fax +44 (0) 1580 200 616

See also
www.elektor-electronics.co.uk

Easy-PC for Windows

World Beating Value in PCB Design Software

from
£97

High performance Windows based PCB Design Capture, Simulation and Layout software at prices you'd expect from your local computer store!



NEW! in Easy-PC 7

- Library Databook
- Step and repeat plotting
- Swap Connection Mode
- Dimensioning
- Copy to Metafile
- plus much more.....

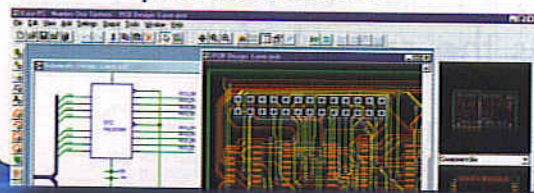

Stop press... by customer demand, now with Tsien Boardmaker 2 design import...

Number One Systems delivers true 32 bit Windows software applications including features that a few short years ago would only have been available in software tools priced in the thousands!

Test drive Easy-PC and Easy-Spice for yourself and be prepared to be amazed at the super value...

Call for a brochure, price list and demo CD on +44 (0)1684 773662 or email sales@numberone.com



Number One Systems

Number One Systems
Oak Lane, Bredon
Tewkesbury, Glos GL20 7LR
United Kingdom

or download from
www.numberone.com

R/C Analyser

a digital tachograph for R/C model cars

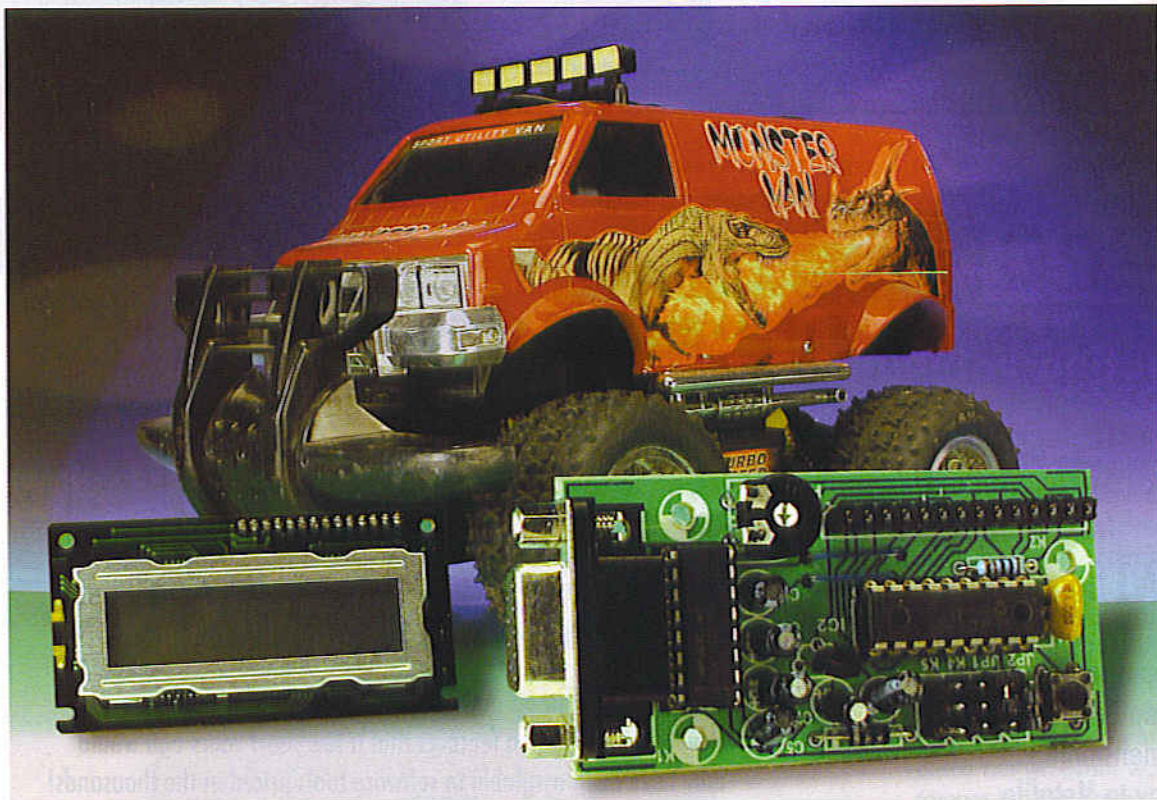

This R/C analyser measures and stores the speed of an R/C model car directly in the car. It is aimed at R/C model car builders who want to know how fast their models can go 'on the road'.

Features

- Supply voltage 5-8 V
- Connectors for all external leads
- Jumper-selectable operating modes
- Simple hardware construction using standard leaded components (Conrad)
- PIC microcontroller
- Contrast adjustment for display
- RS232 interface
- Graphic data presentation
- Connection for external push-button
- Measures, stores and outputs data
- Three rotational sensor options (IR and magnetic)
- All control logic on the analyser board

The R/C analyser measures the speed of a model vehicle. The speed is measured directly in the R/C vehicle, rather than being computed from the number of laps and elapsed time. This means that the speed, and in particular the top speed, can be determined for individual curves and straight-aways. The average lap speed is also

obtained as a 'by-product'.

The rate at which the main gear-wheel is spinning is continually measured using a rotational speed sensor. This continual measurement also allows a wide variety of other factors to be tested and analysed, such as the effect of varying the sizes of the main gearwheel or motor

pinion, using a different motor, or using a different gearbox, in order to optimise the configuration of the R/C model and allow the motor to run in its optimum speed range. This gives ambitious model car racers a real advantage.

The speed is measured and stored once a second. The current

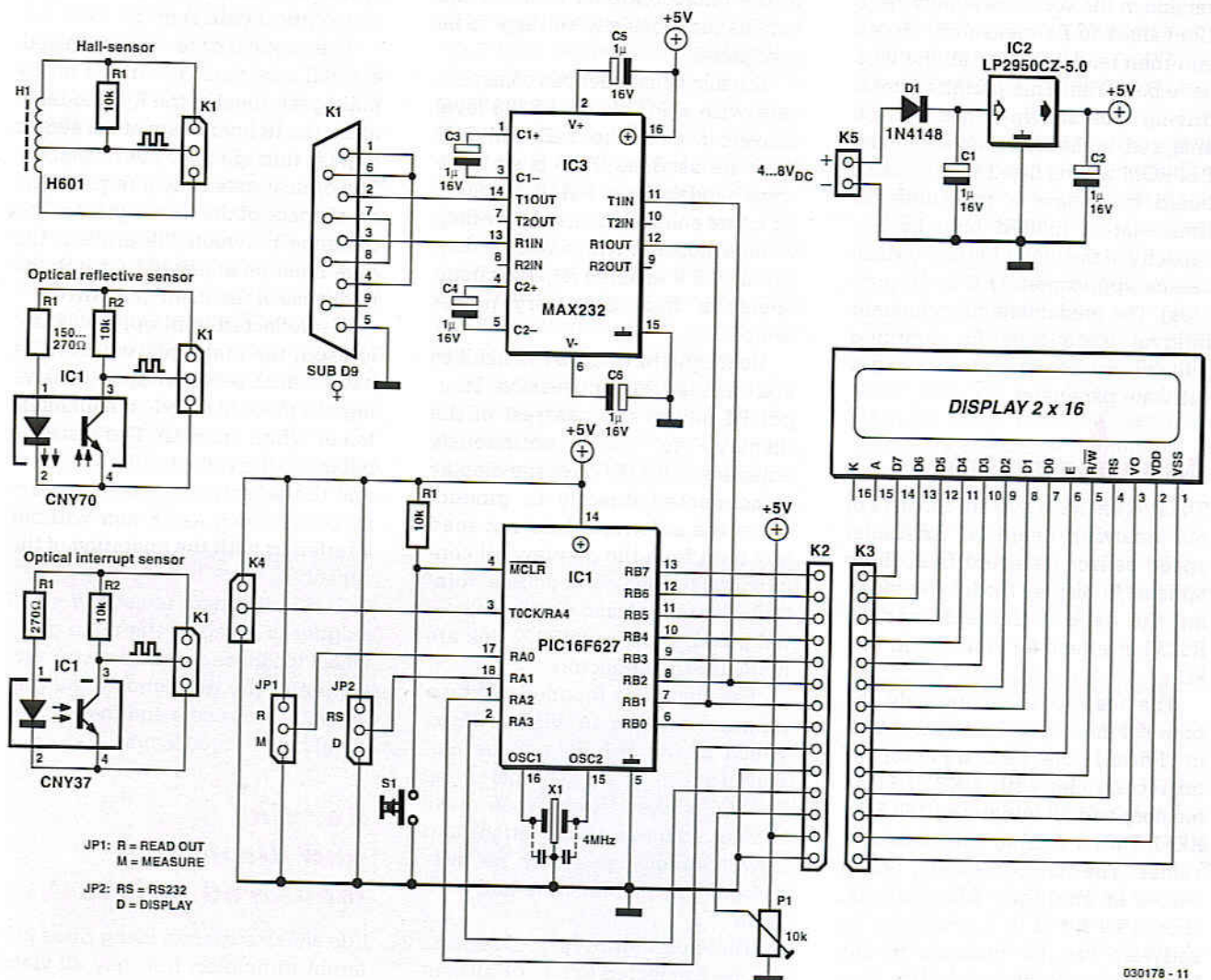

Figure 1. Circuit diagram of the R/C analyser, with three different types of sensors.

Table 1. Operating modes and jumper settings

Measuring	Readout via display	Readout via RS232
Connect K5 to the motor battery or an unused receiver channel (use only the + and – leads)		
Connect K4 to the sensor	Connect K2 to the display	Connect K1 to the RS232 port of the PC
Set JP1 to 'M'	Set JP1 to 'R'	Set JP1 to 'R'
Leave JP2 open	Set JP2 to 'D'	Set JP2 to 'RS'
–	–	Open Excel file <i>rclogex3.xls</i> and press the Start button. The program will sit in an endless loop waiting for data (press ESC to abort).
Press S1		
The first of 120 measurements will be made after the delay expires. The total measurement time is 60 seconds with an 0,5-s window or 120 seconds with a 1-s window.	The measured values are shown sequentially on the display in the form of the measurement number (0–59 or 0–119) and associated measured value (rps).	The measured values are read. After all of the data have been read (approx. 20 s), the message 'Done' will be displayed. Click on OK to acknowledge.
Start a new measurement session by again pressing the button (the previous measurements will be erased)	Start a new readout by pressing the button again (once or twice).	The file RSAPI.DLL, which contains the function library for driving the PC serial interface, must be first copied to the Windows system directory to allow the data to be displayed.

version of the software allows up to 120 values to be measured, stored and then read out after all the laps have been run. This permits a total driving time of two minutes to be analysed. In the future, an additional EEPROM will be fitted to the circuit board to achieve a measurement time that is limited only by the capacity of the motor battery (which means approximately 8 to 10 minutes). The predefined measurement interval (gate time for counting pulses) can be configured using a software parameter.

Analyser system

The R/C analyser system consists of the analyser board, a rotational speed sensor (selected from three options), a display module for viewing the data at trackside and an RS232 interface for connection to a PC.

The heart (or more precisely, the brain) of the analyser system shown in **Figure 1** consists of a PIC16F627 microcontroller with 1 KB of Flash memory and an integrated 128-byte EEPROM for storing the measured values. The microcontroller, which comes in an 18-pin DIL package, should be fitted in a socket so its software can be updated in the future. It is clocked at 4 MHz by a three-lead ceramic resonator. Two jumpers (JP1 and JP2) are connected

to the microcontroller to allow the various functions and settings to be configured.

The microcontroller can communicate with a PC via an RS232 level converter. Only the TxD and RxD lines are used, so there is no hardware handshaking. RxD is included for future enhancements. A low-drop voltage regulator with a voltage drop of only 0.5 V ensures reliable circuit operation from a battery power source.

Reset pushbutton S1 is used to start a measurement session. Trimpot P1 allows the contrast of the display to be continuously adjusted. Pin 5 (R/W) of the display is connected directly to ground, since the software does not read any data from the display. All connections to the power source, rotational speed sensor, display, external pushbutton and RS232 link are made using connectors.

The system is rounded out by a program written in Visual Basic, which allows the data to be displayed and analysed in graphic form. The R/C analyser system is an 'open' system, so future modifications and new features can easily be integrated into the hardware and software.

Three different types of sensors can be connected to K4: a Hall sensor (which responds to a magnetic field, in this case a rotating field), an

optical sensor using reflected light, or an optical gate sensor.

If an optical gate sensor is used, a small hole must be drilled in the main gearwheel of the R/C model to allow the IR light beam of the sensor to pass through once per revolution. The optical gate sensor requires the most space of the three options. The distance between the arms of the gate must be adjusted to match the thickness of the main gearwheel.

If a reflected-light optical sensor is used, the main gearwheel must have a small reflective spot (consisting of a piece of glued-on aluminium foil or white enamel). The distance between the reflected-light sensor and the reflecting surface can easily be as much as 15 mm without interfering with the operation of the sensor.

If a Hall sensor is used, a small magnet is glued to the main gearwheel to induce a pulse for each revolution of the gearwheel. The gap between the sensor and the magnet should not exceed 5 mm.

Reading and displaying measured values

The sensors operate using three different principles, but they all yield the same result. The IR light beam interrupted or reflected by the main

COMPONENTS LIST

Resistors:

R1 = 10k Ω
P1 = 10k Ω preset

Capacitors:

C1-C6 = 1 μ F 16V radial

Semiconductors:

D1 = 1N4148
IC1 = PIC16F627-4/CP, programmed,
order code 030178-41

IC2 = LP2950CZ-5.0
IC3 = MAX232CP

Miscellaneous:

JP1, JP2 = 3-way SIL pinheader with
jumper
K1 = 9-way sub-D socket (female), angled
pins, PCB mount
K2 = 14-way SIL pinheader
K3 = LCD, 2 x 16 characters with
flatcable and 14-way IDC connector

K4 = 3-way pinheader
S1 = pushbutton, 1 make contact (Conrad
Electronics # 704849-8B)
X1 = 4MHz ceramic resonator with 3 pins
and internal capacitors.
PCB, available from **The PCBShop**

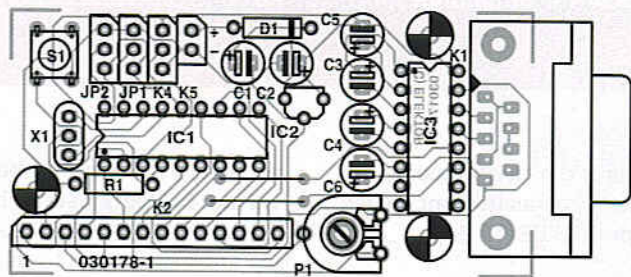

Figure 2. The printed circuit board is compact, despite being single sided and using leaded components.

gearwheel, or the magnetic field in the case of the Hall sensor, causes the sensor to generate a rectangular pulse waveform that is applied to the microcontroller counter input (RA4).

This Schmitt-trigger input feeds the pulses to counter TMR0, which counts the falling edges of the pulses and writes the number of pulses per time unit to the appropriate register, as well as to the internal EEPROM for long-term storage. The time window (1/20, 1/10, 1/2 or 1 s), and with it the number of possible measurements, can be configured as desired using the software.

When a measurement session is

started using S1, there is ten-second delay programmed into the software (this value can be easily modified) to allow the driver to take his or her position at the controls or concentrate on the start. During this delay, the values previously stored in the internal EEPROM of the PIC are erased.

Pushbutton S1 not only starts a measurement session, it also starts data readout and output via the LCD or RS232 interface if JP1 and JP2 are suitably configured (see **Table 1**).

The measurement data are displayed using a two-line LCD module with 16 characters per line. For each measurement, the measurement

number, measured value, and number of revolutions per second (rps) of the main gearwheel are displayed. The speed can be obtained by a simple conversion. In a planned future version of the software, the speed will be shown directly in km/h. The revised version of the software will allow the conversion factor (distance travelled per revolution of the main gearwheel) to be set using a configuration parameter.

The program for reading the data via the serial interface and displaying it on a PC is written in Visual Basic for Excel. A simple user interface allows suitable parameters to be selected and shows the car speed and motor speed in separate charts. This is ideal for tasks such as investigating how different combinations of pinion size and main gearwheel size affect the speed of the motor.

Small circuit board

Although the circuit board for the analyser must be fitted in the R/C car, which means that every square centimetre counts, we managed to come up with a satisfactory solution with a single-sided circuit board using only 'normal' leaded components (**Figure 2**). This spares you the annoyance of working with SMDs, so populating the board is dead easy. There are two wire bridges, and as previously mentioned, the microcon-

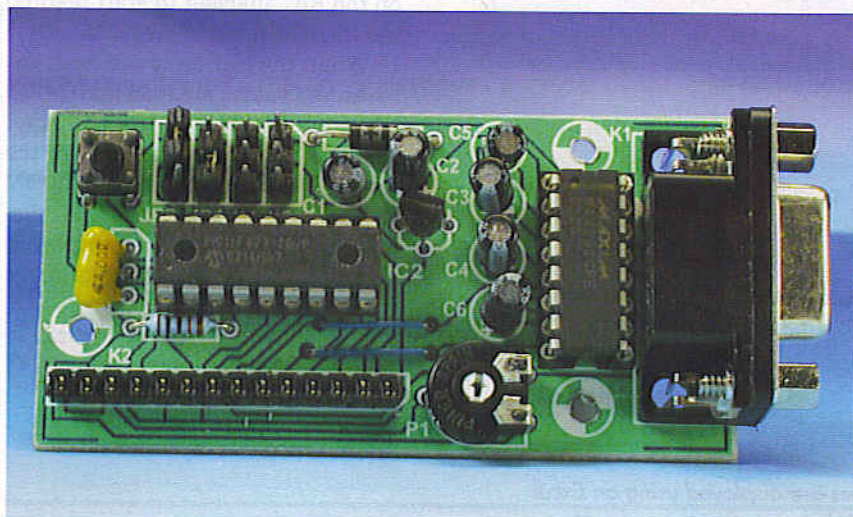

Downloads, planned enhancements, and unplanned ideas

The software for this project is available for download from the Elektor Electronics website under number 030178-11, and the circuit board layout can also be downloaded under number 030178-1. A pre-programmed version of the microcontroller can be obtained from Readers Services under order number 030178-41. Bare printed circuit boards are also available from the PCB Shop (see the Elektor Electronics website).

The author has a website dedicated to the R/C analyser at

www.georgeii.de/analyzer/analyzer.htm. The latest version of the software, including future modifications, enhancements and new ideas, can always be found at this site.

- Storing more than 1000 measurements using an external EEPROM
- Starting a measurement session using the R/C remote control unit
- Using the analyser as a switching module for additional functions

- Illuminating the brake lights by suitable manipulation of the joystick
- Data transfer via ISM radio link
- Temperature sensors
- Reading battery data (e.g. discharge curve)

RSAPI.DLL is available from the website of B. Kainka: <http://home.t-online.de/home/B.Kainka/rsapidll.zip>

troller should be fitted in a socket. If space is tight, you can use a pin header instead of the sub-D socket, along with a suitable adapter.

Software

The entire intelligence of the R/C analyser system is contained in an assembler program. The individual functions, which are programmed as separate modules for ease of understanding, are called from the main routine via jumps. Once each module has finished its job, it makes an orderly return to the main routine. The main routine initialises the inputs and outputs of the PIC, reads

the settings of the two jumpers, and deletes the old measurement values from the internal EEPROM.

Driving the serial interface

The RSAPI.DLL function library allows devices to be driven via the serial interface of the PC. It is typically used for measurement and control applications. Device control is implemented using macros written in VB (Visual BASIC) for standard MS Office programs, such as Word or Excel. A particular advantage of this is that the transferred measurement

values do not have to be first converted, but can instead be entered directly into a spreadsheet. The DLL file must be copied to the Windows system directory in the PC.

The appropriate functions and procedures (subroutines) of RSAPI.DLL are declared in a macro in the Excel document rcllogger3.xls. This informs Basic that it has to use new external functions. These declarations are located at the beginning of the VB module, followed by the routine for reading the measured values.

The interface is initialised and opened using the following configuration parameters: 2400 baud, no parity bit, 8 data bits and 1 stop bit. The Excel worksheet rcllogger is then opened and column B, which contains the values from the previous session, is erased. The macro then waits for new values. The program remains in an endless loop (which can be aborted by pressing the Esc key) until the pushbutton is pressed on the R/C analyser to start reading out the measured values.

When the button is pressed, the measured values are read line by line using the function READBYTE. After the data have been transferred, the interface is closed using CLOSECOM and a message dialogue is displayed. The data are then displayed in an easily understood form, as shown in Figure 3.

(030178-1)

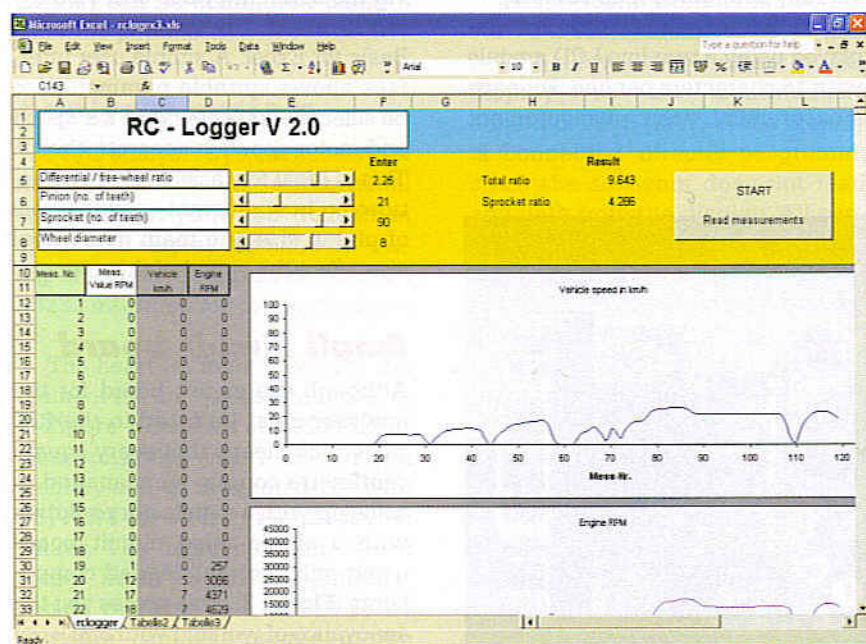

Figure 3. The parameters and measured values are displayed using an Excel worksheet.

PCB-POOL[®]

SERVICING YOUR COMPLETE PROTOTYPE NEEDS

- Prototypes at a fraction of the cost
- Industry standard quality
- Tooling and setup included
- Follow up series runs
- Any contour
- CAM / CAD consulting
- Fr4 1.6mm, 35µm Cu

PRICE EXAMPLE:
1 EUROCARD DS/PTH
+ Tooling
+ Photoplots
+ VAT

= £ 29.89*

*Sterling rates may vary. Price = € 49

€ 49

FREE

with first order
on PCB STOCKS ONLY



may differ slightly
to model shown

data

Tel: +353 00461 701170
Fax: +353 00461 701164
E-Mail: sales@pcb-pool.com

Freephone
0800-389 8560

Simply send your files and order ONLINE:

WWW.PCB-POOL.COM

VARSET Pretel Orcad GraphiCode PROTELS Electronics

PicoServ provides all that is required to enable an Internet web server to be integrated into your system or product, providing remote control and remote access via the Web or mobile phone



Simply Embed the Internet with PICO SERV

Creating a web browser or mobile phone based interface is simple using the modular PicoServ system.

The PicoServ web module takes care of

- Network interfacing
- Internet protocols
- Web page storage

PicoServ I/O modules provide simple analogue and digital interfaces to the real world and the SMS gateway module allows remote access using a mobile phone.

Basic HTML programming is all that is required for you to be rapidly in control of your system from anywhere!

Compulogic

Find out more...

www.compulogic.info

info@compulogic.co.uk

or call +44 (0) 1234 756048

- HOME AUTOMATION
- INDUSTRIAL AUTOMATION
- REMOTE SENSING
- REMOTE CONTROL
- ENVIRONMENTAL MONITORING
- ALARM MONITORING
- EMERGENCY CALL
- LOW COST
- LOW POWER
- SMALL SIZE

elektor
electronics

New Micro Web Server for Internet and Intranet

Our incredibly popular MSC1210 microcontroller board (also known as 'Precision Measurement Central') now provides network and Internet connectivity, allowing the processor to publish its own data pages onto the web. The article describes a temperature logger allowing the user to enter, via the Internet, temperature limits and an email alarm address. The Micro Web Server can also switch network ports from an Internet-connected PC, literally anywhere on the globe.

Now available:

- **MSC1210 board** (assembled and tested) £ 69.00 (US\$ 112.50)
- **Network extension** (assembled and tested) £ 41.95 (US\$ 73.95)
- **Combined package** (incl. all related Elektor Electronics articles on diskette) £ 103.50 (US\$ 184.95)



All software for the project is available free of charge from our website!

Order now using the Order Form in the Readers Services section in this issue.

Elektor Electronics (Publishing)
P.O. Box 190
Tunbridge Wells TN5 7WY England
Telephone +44 (0) 1580 200 657
Fax +44 (0) 1580 200 616

See also
www.elektor-electronics.co.uk

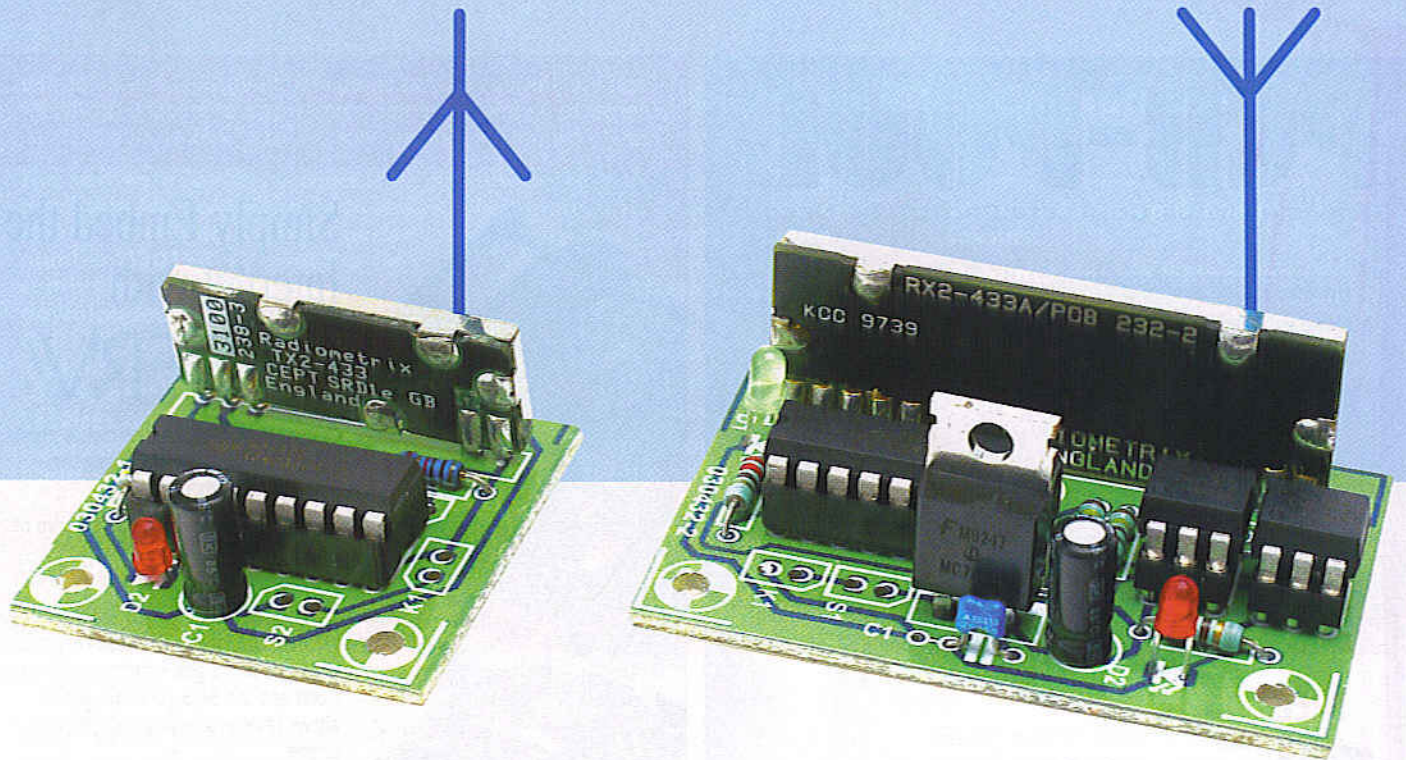

Rajkumar Sharmar

Canon EOS Cameras go Wireless

Using 433-MHz SRD modules

Sure, RF Remote control is desirable if you're into aerial, wildlife, candid or physically dangerous photography, but prepare for a shock if you shop around for commercially available remote controls.

COMPONENTS LIST

Transmitter

Resistors:

R1 = 10k Ω
R2 = 470 Ω
R3 = 976k Ω 1%

Capacitors:

C1 = 10 μ F 25V radial

Semiconductors:

D1 = 1N4148
D2 = LED, red
IC1 = HT12E (Holtek) (Maplin Electronics)

Miscellaneous:

ANT1 = stiff wire, length approx. 15.5cm
BT1 = 9V battery connection

MOD1 = TX2 433MHz SRD radio module (Radiometrix). Equivalents from LPRS (www.lprs.co.uk)

S1 = pushbutton, 1 make contact (see also inset)
S2 = on/off switch

Receiver

Resistors:

R1 = 51k Ω 1%
R2, R3 = 220 Ω
R4, R5 = 150 Ω

Capacitors:

C1 = 100nF
C2 = 10 μ F 25V radial

Semiconductors:

D1 = LED, green
D2 = LED, red
IC1 = HT12D (Holtek) (Maplin Electronics)
IC2 = 7805
IC3, IC4 = CNY17-2

Miscellaneous:

ANT1 = stiff wire, length approx. 15.5cm
BT1 = 9V battery connection
K1 = mini jack plug (2.5mm) with 3-wire cable
MOD1 = RX2 433MHz SRD receiver module (Radiometrix). Equivalents from LPRS (www.lprs.co.uk)
S1 = on/off switch
PCB available from **The PCBShop**

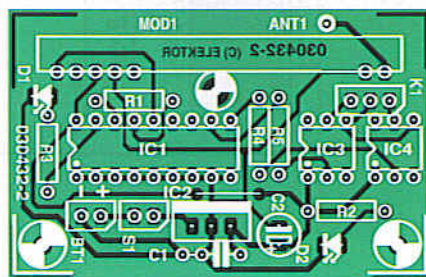
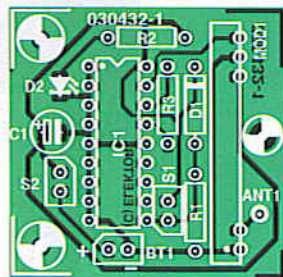

Figure 3. Component mounting plan. The copper track layout may be found on the PCB layouts page towards the back of this issue.

controlled) sequence if you modify the circuit as shown in the inset.

Moving on to **Figure 2** we see that the receiver is hardly more complex than the transmitter. Here, the HT12D decoder (IC1) will decode the datastream received from the Radiometrix RX2 module. If the communication is faultless, LED D1 lights and outputs D8 and D9 on the HT12D assume the same digital level as their TX counterparts AD8 and AD9 on the HT12E. Via optocouplers IC4 and

IC5 and mini jack plug K1, the camera is then instructed to perform the aperture measurement and then take the picture just as if you'd pressed the relevant button on the camera.

Construction

The transmitter and receiver are built on miniature boards (**Figure 3**) so they can be fitted into compact plastic enclosures. As only regular-size com-

ponents are used in this project, no problems are envisaged in the construction department. To ensure sufficient range for the remote control, the antennas must, of course, protrude from the cases and be kept well removed from metal objects like a tripod. In practice, you'll find that the usable range of the system will be about 100 m out of doors. Inside buildings, the range will be much smaller.

(030432-1)

Double-action click

Optionally, the circuit may be modified as shown here if you want real double-click operation from your camera (click #1 to perform various settings and click #2 to release the shutter). Although switches S1a and S1b are shown as coupled they are in fact actuated in sequence rather than simultaneously.

A suggested switch of this type is distributed by Singatron (www.singatron.com/switch/switch/ctl.pdf), alternatively look at Alps products (www3.alps.co.jp/indexpdf_switches-e.html).

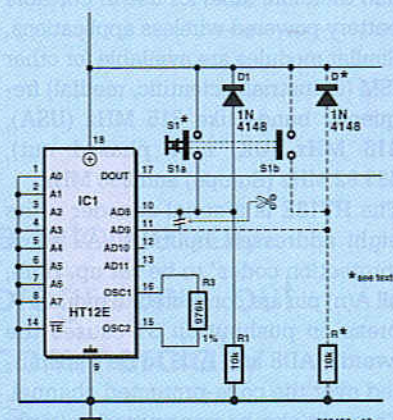

Visit our website
www.distel.co.uk

THE ORIGINAL SURPLUS WONDERLAND!

THIS MONTH'S SELECTION FROM OUR VAST EVER CHANGING STOCKS

Surplus always
wanted for cash!

GIANT 10" 7 SEGMENT DISPLAYS

A bulk purchase enables us to bring to you these GIANT 7 segment digital displays at a now affordable price! The 10" character size gives exceptional readability at long distances and enables a host of applications including score boards, digital clocks, counters, event timers etc. As the units are a simple electromechanical device and operate from 12V DC, simple switching via switches, relays, PIC or PC may be used to control single or multiple digits. Units feature integral 'Zero Power' memory which greatly simplifies design. For an excellent DIY practical article, see the May issue of 'Everyday & Practical Electronics' magazine, Ideal School / College construction project. Supplied in good RFE condition, complete with data sheet.



Less than 30% of makers price! Order RW44 Order PR26

THE AMAZING TELEBOX



TV SOUND & VIDEO TUNER
CABLE COMPATIBLE*

Converts your colour monitor into a QUALITY COLOUR TV!!

The TELEBOX is an attractive fully cased mains powered unit, containing all electronics ready to plug into a host of video monitors or AV equipment which are fitted with a composite video or SCART input. The composite video output will also plug directly into most video recorders, allowing reception of TV channels not normally receivable on most television receivers* (TELEBOX MB). Push button controls on the front panel allow reception of 8 fully tuneable off air UHF colour television channels. TELEBOX MB covers virtually all television frequencies VHF and UHF including the HYPERBAND as used by most cable TV operators. Ideal for desktop computer video systems & PIP (picture in picture) setups. For complete compatibility - even for monitors without sound - an integral 4 watt audio amplifier and low level Hi Fi audio output are provided as standard. Brand new - fully guaranteed.

TELEBOX ST for composite video input type monitors £36.95
TELEBOX STL as ST but fitted with integral speaker £39.50
TELEBOX MB Multiband VHF/UHF/Cable/Hyperband tuner £69.95
For overseas PAL versions state 5.5 or 6 MHz sound specification.
*For cable / hyperband signal reception Telebox MB should be connected to a cable type service. Shipping on all Telebox's, code (B)

NEW State of the art PAL (UK spec) UHF TV tuner module with composite IV pp video and NICAM Hi fi stereo sound outputs. Micro electronics all on one small PCB only 73 x 160 x 52 mm enable full tuning control via a simple 3 wire link to an IBM pc type computer. Supplied complete with simple working program and documentation. Requires +12V & +5V DC to operate. **BRAND NEW - Order as MY00. Only £39.95 code (B)**
See www.distel.co.uk/data_my00.htm for picture + full details

HARD DISK DRIVES 2 1/2" - 14"

2 1/2" TOSHIBA MK1602MAV 1.1Gb laptop (12.5 mm H) New £59.95
2 1/2" TOSHIBA MK4313MAT 4.3Gb laptop (8.2 mm H) New £105.00
2 1/2" TOSHIBA MK6405MAV 6.1Gb laptop (12.7 mm H) New £149.95
2 1/2" TOSHIBA MK1814GAV 18 Gb laptop (12.5 mm H) New £155.95
2 1/2" to 3 1/2" conversion kit for Pc's, complete with connectors £15.95
3 1/2" COMPAQ 313706-B21 (IBM) 9 gb ULT/SCSI3 New £199.00
3 1/2" FUJI FK-309-26 20mb MFM I/F RFE £59.95
3 1/2" CONNER CP3024 20 mb IDE I/F (or equiv.) RFE £59.95
3 1/2" CONNER CP3044 40 mb IDE I/F (or equiv.) RFE £69.00
3 1/2" QUANTUM 40S Prodrive 42mb SCSI I/F, New RFE £49.00
5 1/4" MINISCRIBE 3425 20mb MFM I/F (or equiv.) RFE £49.95
5 1/4" SEAGATE ST-238R 30 mb RLL I/F Refurb £69.95
5 1/4" CDC 94205-51 40mb HH MFM I/F RFE tested £69.95
5 1/4" HP 97548 850 Mb SCSI RFE tested £99.00
5 1/4" HP C3010 2 Gbyte SCSI differential RFE tested £195.00
8" NEC D2246 85 Mb SMD interface. New £99.00
8" FUJITSU M2322K 160Mb SMD I/F RFE tested £195.00
8" FUJITSU M2392K 2 Gb SMD I/F RFE tested £345.00
Many other floppy & H drives, IDE, SCSI, ESDI etc from stock, see website for full stock list. Shipping on all drives is code (C)

IC's - TRANSISTORS - DIODES

OBSELETE - SHORT SUPPLY - BULK
10,000,000 items EX STOCK

For MAJOR SAVINGS
CALL or see web site www.distel.co.uk

COMPUTER MONITOR SPECIALS

Legacy products
High spec genuine multisync.
CGA, EGA, VGA, SVGA

Mitsubishi FA3415ETKL 14" SVGA Multisync colour monitor with fine 0.28 dot pitch tube and resolution of 1024 x 768. A variety of inputs allows connection to a host of computers including IBM PC's in CGA, EGA, VGA & SVGA modes. BBC, COMMODORE (including Amiga 1200), ARCHIMEDES and APPLE. Main features: Etched faciplata, text switching and LOW RADIATION MPR specification. Fully guaranteed, in EXCELLENT little used condition. Tilt & Swivel Base £475

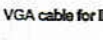

VGA cable for IBM PC included. Order as CG73

Only £129 (E) Order as CG73

External cables for other types of computers available - CALL

Generic LOW COST SVGA Monitors

We choose the make, which includes Compaq, Mitsubishi, IBM, etc. Supplied ready to run with all cables. Standard RTB 90 day guarantee.

14" £59.00 order TD84
15" £69.00 order TG21
17" £79.00 order TJ66

Supplied in good used condition. Shipping code (D)

VIDEO MONITORS

PHILIPS HCS35 (same style as CM8833) attractively styled 14" colour monitor with both RGB and standard composite 15.625 KHz video inputs via SCART socket and separate phono jacks. Integral audio power amp and speaker for all audio visual uses. Will connect direct to Amiga and Atari BBC computers. Ideal for all video monitoring / security applications with direct connection to most colour cameras. High quality with many features such as front concealed flap controls, VCR correction button etc. Good used condition - fully tested - guaranteed
Dimensions: W14" x H12 1/4" x 15 1/2" D.
Only £99.00 (D)

PHILIPS HCS31 Ultra compact 9" colour video monitor with standard composite 15.625 KHz video input via SCART socket. Ideal for all monitoring / security applications. High quality, ex-equipment fully tested & guaranteed (possible minor screen burns). In attractive square black plastic case measuring W10" x H10" x 13 1/2" D. 240 V AC mains powered.
Only £79.00 (D)

INDUSTRIAL COMPUTERS

Tiny shoebox sized industrial 40 Mhz 386 PC system measuring only (mm) 266 w x 88 h x 272 d. Ideal for dedicated control applications running DOS, Linux or even Windows I Steel case contains 85 to 265 V AC 50 / 60 Hz 70 Watt PSU, a 3 slot ISA passive backplane and a Rocky 318 (PC104) standard, single board computer with 8 MByte NON VOLATILE solid state 'Disk On Chip' RAMDISK. System comprises: Rocky 318 (PC104) SBC ISA card with 40MHz ALI 386SX CPU, 72 pin SIMM slot with 16 MByte SIMM, AMI BIOS, battery backed up real time clock. 2 x 8 pin D 16550 serial ports. EPP/ECP printer port, mini DIN keyboard connector, floppy port, IDE port for hard drives up to 528 MByte capacity, watchdog timer and PC/104 bus socket. The 8 MByte solid state 'disk on a chip' has its own BIOS, and can be fiddled, formatted & booted. Supplied BRAND NEW fully tested and guaranteed. For full data see featured item on website. Order as QG36
100's of applications inc: firewall, routers, robotics etc
Only £99.00 (D)

TEST EQUIPMENT & SPECIAL INTEREST ITEMS

MITSUBUSHI FA3445ETKL 14" Ind. spec SVGA monitors £245
FARNELL 0-60V DC @ 50 Amps, bench Power Supplies £995
FARNELL AP3090 0-30V DC @ 80 Amps, bench Supply £1850
KINGSBILL CZ4031 0-50V @ DC 200 Amps - NEW £3950
1kW to 400 kW - 400 Hz 3 phase power sources - ex stock EPOA
IBM 8230 Type 1, Token ring base unit driver £780
Wayne Kerr RA200 Audio frequency response analyser £2500
IFODEC 1U, 24 port, RJ45 network patchpanels. #TH93 £49
3COM 16670 12 Port Ethernet hub - RJ45 connectors #LD97 £89
3COM 16671 24 Port Ethernet hub - RJ45 connectors £89
3COM 16700 8 Port Ethernet hub - RJ45 connectors NEW £39
IBM 53F5501 Token Ring ICS 20 port lobe modules £39
IBM MAU Token ring distribution panel 8228-23-5050M £45
AIM 501 Low distortion Oscillator 9Hz to 330KHz, IEEE I/O £550
ALLGON 8360, 11805-1880 MHz hybrid power combiners £250
Trend DSA 274 Data Analyser with G703(2M) 64 I/O EPOA
Marconi 6310 Programmable 2 to 22 GHz sweep generator £4500
Marconi 2022C 10KHz-1GHz RF signal generator £1550
HP1650B Logic Analyser £3750
HP3781A Pattern generator & HP3782A Error Detector EPOA
HP6621A Dual Programmable GPIB PSU 0-7 V 160 watts £1800
HP6264 Rack mount variable 0-20V @ 20A metered PSU £475
HP54121A DC to 22 GHz four channel test set EPOA
HP1830A opt 020 30 MHz pulse generator, GPIB etc £7900
HP A1, A0 8 pen HPGL high speed drum plotters - from HP DRAFTMASTER 18 pen high speed plotter £550
EG+G Brookdek 95035C Precision lock in amp £1800
Keithley 900 CV capacitor / voltage analyser EPOA
Racal ICR40 dual 40 channel video recorder system £3750
Fiskers 450VA 3 ph On Line UPS - New batteries £4500
Emerson AP130 2.5KVA Industrial spec UPS £1499
Mann Tally MT645 High speed line printer £2200
Intel SBC 486/133SE Multibus 486 system, 8Mb Ram £945

Unless marked NEW, items in this section are pre owned.
HP6030A 0-200V DC @ 17 Amps bench power supply £1950
Intel SBC 486/125C08 Enhanced Multibus (MSA) New £1150
Nikon HFX-11 (Ephiphot) exposure control unit £1450
PHILIPS PM5518 pro. TV signal generator £1250
Motorola VME Bus Boards & Components List. SAE / CALL EPOA
Trio 0-16 vdc linear, metered 30 amp bench PSU. New £550
Fujiitsu M3041R 600 LPM high speed bench printer £1950
Fujiitsu M3041D 600 LPM printer with network interface £1250
Siemens K4400 64Kb to 140Mb demux analyser £2950
Perkin Elmer 299B Infrared spectrophotometer £500
VG Electronics 1035 TELETEXT Decoding Margin Meter £3500
LightBand 50 output high spec 2u rack mount Video VDA's £2950
Sekonik SD 150H 18 channel digital Hybrid chart recorder £1995
B&K 2633 Microphone pre amp £750
Taylor Hobson Talysurf amplifier / recorder £750
ADC SS200 Carbon dioxide gas detector / monitor £1450
BBC AM20/3 PPM Meter (Ernest Turner) + drive electronics £75
ANRITSU 9654A Optical DC-2.5Gb waveform monitor £5650
ANRITSU ML93A optical power meter £990
ANRITSU Fibre optic characteristic test set EPOA
R&S FTDZ Dual sound unit £650
R&S SBUF-E1 Vision monitor £775
WILTRON 6630B 12.4 / 20GHz RF sweep generator £5750
TEK 2445 150 MHz 4 trace oscilloscope £1250
TEK 2465 300 MHz 300 MHz oscilloscope rack mount £1955
TEK TDS380 400MHz digital realtime + disk drive, FFT etc £2900
TEK TDS524A 500MHz digital realtime + colour display etc £5100
PH3585A Opt 907 20Hz to 40 MHz spectrum analyser £3950
PHILIPS PW1730/10 60KV XRAY generator & accessories EPOA
VARIACS - Large range from stock - call or see our website
CLAUDE LYONS 12A 240V single phase auto. volt. regs £325
CLAUDE LYONS 100A 240/415V 3 phase auto. volt. regs £2900

DISPLAY ELECTRONICS

ALL MAIL TO
Dept EK, 29 / 35 Osborne Rd
Thornton Heath
Surrey CR7 8PD, UK
Open Mon - Fri 9.00 - 5:30

18 Million Items On Line Now!
Secure Ordering, Pictures, Information
www.distel.co.uk
email = admin@distel.co.uk

ALL ENQUIRIES
0208 653 3333
FAX 0208 653 8888

All prices for UK Mainland, UK customers add 17.5% VAT to TOTAL order amount. Minimum order £10. Bona Fide account orders accepted from Government, Schools, Universities and Local Authorities - minimum account order £100. Cheques over £100 are subject to 7 working days clearance. Carriage charges (A)=£3.50, (B)=£6.50, (C)=£10, (D)=£15.00, (E)=£18.00, (F)=CALL. Allow approx 3 days for shipping - faster CALL. All goods supplied to our Standard Conditions of Sale which can be viewed at our website and unless stated guaranteed for 90 days. All guarantees on a return to base basis. All rights reserved to change prices / specifications without prior notice. Orders subject to stock. Discounts for volume. Top CASH prices paid for surplus goods. All trademarks, tradenames etc acknowledged. © Display Electronics 2002. E & O E.

MAX6954 Display Driver

A driver for 14/16 segment displays

A. Köhler

LED displays offer a number of advantages over other display technologies: they are reliable, robust, easily readable from a wide viewing angle and are relatively simple to drive. Along with the more usual 7-segment and dot matrix types come the 14/16 segment displays. This article takes a closer look at a versatile driver IC from Maxim.

14/16-Segment displays are arranged like 7-segment types but with additional diagonals and centre vertical segments. These extra segments allow many more characters (including special characters) to be displayed but the extra segments demand a more complex driver circuit. There is any number of 7-segment drivers on the market but for 14/16 displays the choice is relatively small. The

MAX 6954 and MAX 6955 from Maxim are designed to meet this need and can also drive 7-segment displays and discrete LED indicators.

SPI or I²C?

The function of both the MAX6954 and MAX6955 are similar. The only difference between the two devices is the interface standard used to connect the device to the

microcontroller. The MAX6954 uses an SPI (serial programming interface) while the MAX6955 uses an I²C interface. Both ICs are highly integrated and this short article only touches on some of the features of the chip, for a more detailed description it is necessary to refer to the (38 page) data sheet [1].

Figure 1 shows the internal block diagram of the MAX6954 and the complete circuit diagram for this application. The supply voltage should lie between 2.7 V and 5.5 V (it can withstand 6 V for a short period only). The supply current consumption is 35 mA maximum and typically 22 mA. Current to the segments is limited by an internal programmable constant current source. The character driver can be programmed so that the intensity of the entire eight display characters is defined together (globally) or the intensity of each character is individually programmed. The intensity is defined by the value of the lower four bits written to the intensity register. This allows

16 steps in the display brightness so with a segment drive source current of typically 40 mA, each step represents a 2.5 mA reduction in the drive current.

The internal clock frequency is controlled by an external capacitor (typically 22 pF) connected between the OSCIN input pin and ground. All the internal processes in the LED controller including the LED blink frequency are referenced to this oscillator clock. The clock output from OSCOUT (pin 37) can be used to synchronise external circuitry to this driver clock.

The LED drive circuitry has 19 outputs O0 to O18 and employs a number of different multiplexing techniques to reduce wiring complexity. Firstly the drive is time multiplexed so that at one point in the cycle the lower eight outputs are used to sink current from the common cathode connection of the LED while at other times the current direction is reversed and the output acts as a current source to drive an individual

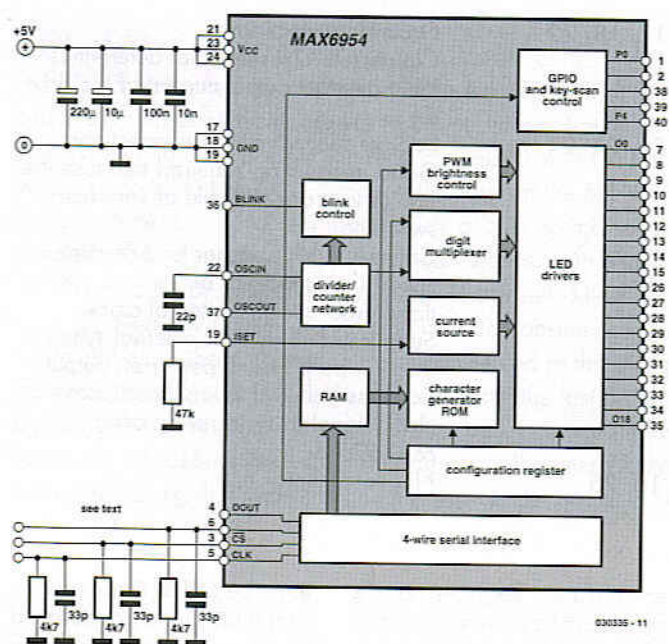

Figure 1. Circuit diagram showing internal block diagram of the 40-pin DIL version.

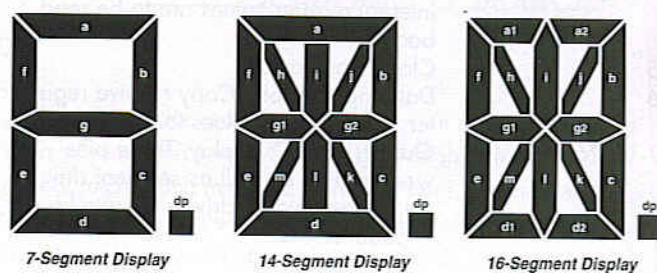

Figure 2. 7, 14 and 16 Segment LED displays.

segment on the display. The display brightness is controlled by using pulse width modulation. A built-in current source generator limits the maximum LED current and a single resistor connected between pin 19 and ground defines the value of this current. The manufacturer suggests a resistor value of 56 kΩ.

Each display position has two registers associated with it (called plane 0 and plane 1). One of these registers contains the actual display information whilst the other register is a 'background' register. This allows new information to be loaded to the background register and then quickly swapped with the display register using just a single command. An internal decoder and character generator allows 104 characters from the ASCII character set (including some special characters) to be displayed. The chip also contains a decoder for use with seven-segment LEDs.

Some of the outputs can also be used to scan up to

32 input switches or a keyboard. The chip also performs built-in switch debouncing. A part of this keyboard interface can also be used as a general-purpose I/O port.

The internal Registers

The display driver has a complicated internal structure including a large number of internal configuration registers to control the chip and all its functions. The values that need to be written to these registers and their interdependence on the contents of other registers make the programming process a little complicated.

Some of the important registers used in our application are described below but for a fuller appreciation of the capabilities of this chip it is necessary to spend a little time studying the data sheet.

No-op (00H)

This allows data to be sent to just one driver chip when, say, four are daisy chained together. The No-op com-

mand is sent to the other three devices.

Decode-Mode (01H)

This register determines whether the ASCII decoder will be used to generate the displayed character or the LED segments will be individually driven. The type of LED used (defined in register 0CH) will influence the decoded output.

Global Intensity (02H)

If the global bit is set in 0C register the entire display can be dimmed (15 levels).

Scan Limit (03H)

Sets the number of segments used for the display LEDs. Also used to limit the number of keys scanned if input keys are used.

Configuration (04H)

This register controls the configuration of the chip. For normal operation Bit 0 must be set to a '1' otherwise the chip enters its shutdown mode. Bit 1 is unused. Bit 2 controls the blink rate. If the bit is set the blink rate will be approxi-

mately 2 Hz otherwise it will be around 1 Hz (assuming a 4 MHz clock). Bit 3 inhibits (0) or enables (1) display blinking. The blinking can be used to flash the display on and off or alternately to display two different characters. Bit 4 resets the blink timer. This is useful in a system with multiple display drivers: resetting this bit on all the drivers in quick succession will ensure that blinking of all the displays will be synchronised. Bit 5 clears all the display data stored in both display planes. Bit 6 is used to define the type of display intensity control. A '0' in this position means that the intensity of the whole display will be set by the value stored in register 02. A '1' allows each displayed character to have an intensity defined by the 4-bit values stored in registers at address 10H to 17H. Bit 7 is read only and indicates whether the display is currently on or off in the blink cycle.

GPIO Data (05H)

This register is used to output

Connection(s)	Function
1, 2, 38, 39, 40	Freely programmable I/O-Ports, configurable as inputs or as open-drain outputs. Also used by keyboard interface.
3	CS connection of SPI.
4	Allows multiple MAX6954's to be daisy-chained. Also acts as a data output if internal register values are to be read back.
5	Clock input for SPI.
6	Data input for SPI. Copy receive register numbers and values to this pin.
7-15, 26-35	Outputs for LED display. These pins work in digit as well as segment drivers. Non-activated drivers go into high impedance state.
17, 18, 20	Ground connections.
19	Connected to resistor that determines the maximum output current of the drivers.
21, 23, 24	Positive supply voltage connections. Good decoupling required because the LED drivers are capable of very fast switching.
22	Connect to a capacitor to determine speed (frequency) of all internal operations. Also accepts external clock.
36	Supplies blink rate for external synchronisation purposes. Open-drain output.
37	Supplies buffered Internal oscillator clock signal to synchronise other MAX6954s.
16, 25	Not connected.

data on the General Purpose I/O pins. Input data can be read from address 85H.

Port Configuration (06H)

Selects how the five port pins outputs are used in the circuit.

Display Test (07H)

A 1 in this register will light all the LED segments including the decimal point. Normal operation continues when the register is 0.

Key Mask/Key Debounce (08H to 0BH)

These four registers are used if a keypad is connected, it allows some selected (masked) keys to generate an interrupt when the key press has been debounced.

Digit Type/Key Pressed (0CH)

The type of display can be written to this register. The register is divided into 4 'slots' of 2 bits, these are used to define the display type. Maxim have an example configuration program available to download from their website.

Intensity (10H to 17H)

This changes the brightness of each individual character or of all characters together

depending on the global bit setting in the configuration register (0CH).

Digit Plane 0 (20H to 2FH)

These 16 registers store the displayed characters. The interpretation of these characters is dependant on the number of segments used for the display LED used (digit type in register 0CH). For 14 or 16 segment displays the seven LSBs indicate the ASCII value of the display character. The MSB controls the decimal point. In 7-segment mode with decoding bits D0 to D3 are decoded via the ASCII look up table while D7 controls the decimal point. If the decode mode is not selected each bit will directly control an LED. These registers act as the 'foreground' stores and are displayed during the first blink phase (plane P0).

Digit Plane 1 (40H to 4FH)

Identical to Digit Plane 0 but the contents are displayed in the second blink phase (background register).

Digit Plane 0/1 (60H to 6FH)

Data written to these address ranges will write to both P0 (20H to 2FH) and P1 (40H to 4FH) at the same time. These

are not new registers but a command to write to both the P0 and P1 register stores together.

Key Debounced/Pressed (88H to 8FH)

A '1' in any position in this register indicates that a key press was detected in this position during the last key scan routine. It can determine if the key was pressed momentarily or if the key was held down.

The internal ASCII character generator does not contain any lower-case characters (they cannot be represented on the displays) and will always output upper-case characters irrespective of whether the upper case or lower case ASCII code is used. The special characters are displayed using codes in the range of 08H to 2FH.

A simple application

The circuit diagram of a simple application example (Figure 1) shows how few external components are necessary to implement a display. The most difficult part of circuit construction is the wiring between the driver circuit

and the LEDs. Connections to the LEDs are not detailed on the circuit diagram because pin-outs are generally not consistent between different types of LED from different manufacturers. The data sheet from Maxim details these interconnections (O0 to O18) to various display devices including a discrete LED matrix and 7 to 16 segment displays.

The SPI to the driver chip uses a minimum of three signal wires (together with earth of course). An extra wire can be fitted (DOUT pin 4) if it is necessary to read back information from the chip registers. Included with the development board from Maxim is a complete software package for program development, the author chose QBASIC. This software allows simple access to the PC parallel printer port running in DOS. The source files are all available free to download from the Elektor Electronics website, look for file number 030335-11 under month of publication.

The first program employs some of the basic features of the MAX6954. Eight values are input and displayed on the LEDs. The

SPI data transfer

The input signal thresholds of the SPI-Interface are fixed at 0.6 V and 1.8 V, this enables the device to be interfaced directly to both 3 V-CMOS and 5 V-TTL logic families. The input current to the interface is approximately 1 mA. Signal reflections on the SPI interface can sometimes be a problem (particularly at 5 V) so it is recommended to terminate the DIN, \overline{CS} and CLK signals with either a 4.7 K Ω or a 33 pF capacitor to ground. To transfer data a the \overline{CS} input is pulled low to indicate the start of data transmission, the most significant bit of the data stream is now presented to the DIN pin and this bit is clocked into an internal shift register on the rising edge of the clock. This process repeats until the last bit of the data stream is received, \overline{CS} now goes high before the clock signal goes low and this will store the received message into an internal latch. Each message is 16 bits long, the most significant eight bits defines both the 7-bit address of the internal register and the read/write bit while the next eight bits are the data to be written into that register. The chip can be clocked at 8 MHz but MAXIM recommend a more conservative 4 MHz.

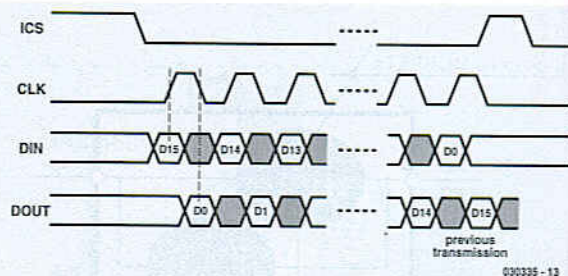

program consists of an initialisation routine, display data input and a central data transfer routine. The

second program implements a running-text display with a maximum message length of 80 characters. The initial-

isation procedure is identical to the first program. Both of the programs are a little basic (ouch) but should help

to clarify the steps necessary to configure the internal registers.

(030335-1)

See your design in print!

Elektor Electronics (Publishing)

are looking for

Freelance Technical Authors/Designers

If you have

- * an innovative or otherwise original design you would like to see in print in Europe's largest magazine on practical electronics
- * above average skills in designing electronic circuits
- * experience in writing electronics-related software
- * basic skills in complementing your design with an explanatory text
- * a PC, email and Internet access for efficient communication with our in-house design staff

then do not hesitate to contact us for exciting opportunities in getting your designs published on a regular basis.

Elektor Electronics

K. Walraven, Head of Design Dept.

P.O. Box 75, NL-6190-AB Beek, The Netherlands, Fax: (+31) 46 4370161

Email: k.walraven@segment.nl

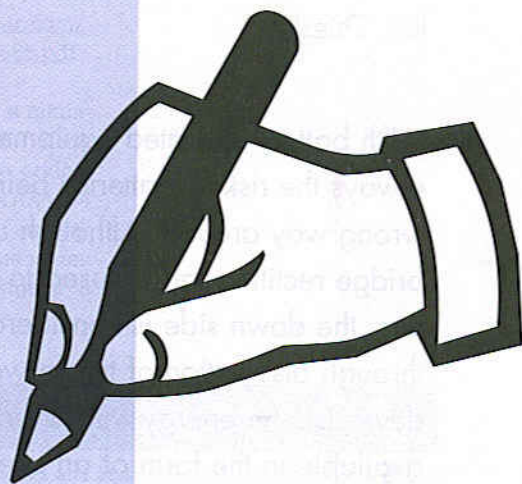

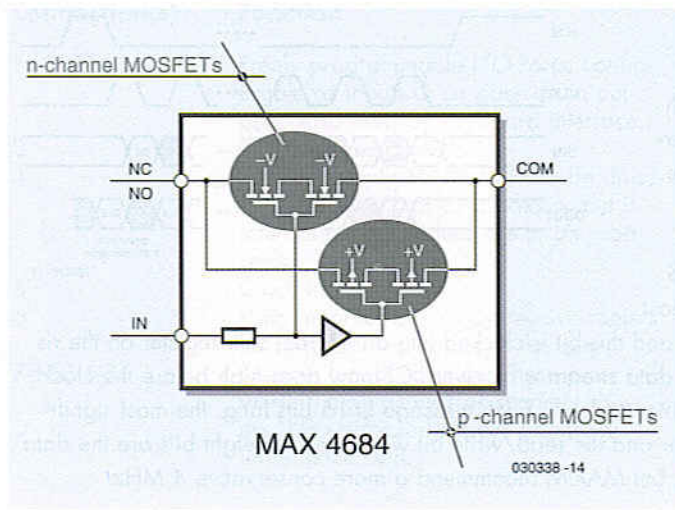

Figure 1. The switches consist of two MOSFETs (P- and N-channel).

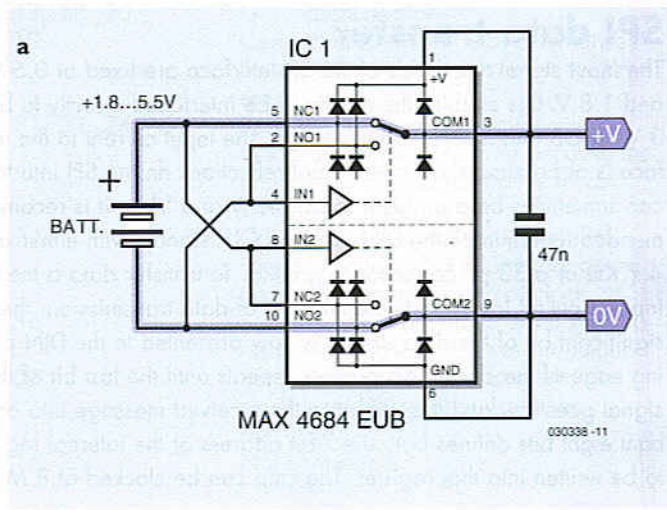

Figure 2. Current paths with correctly (a) and ...

Battery Polarity Protection

Look, no diodes, no relays!

K.-J. Thiesler

With battery-operated equipment there's always the risk of batteries being inserted the wrong way around. Although a diode or a bridge rectifier can be used to solve the problem, the down side is considerable energy loss through dissipation of the forward biased device(s). An energy-wise alternative is now available in the form of an integrated circuit containing two analogue change-over switches.

For sure, switching devices using CMOS technology have been around for a long time, but it was not until the requirements of mobile phones and portable test equipment forced chip designers to make substantial

improvements to the venerable 4000 series of CMOS logic ICs. The 'retrofit' circuit described in this short article is based on the MAX4684 (from Maxim) and is capable of automatically swapping (or, if you like, correcting) the

polarity of a battery set. The circuit can work from a voltage as low as 1.8 V, which may be supplied by two totally exhausted dry batteries, NiCd or NiMH cells in series.

The internal architecture of the chip as pictured in Figure 1 shows two single-pole changeover switches realised using P-channel and N-channel MOSFETs. These devices are marked by a extremely low 'on' resistance, while acting very fast and being capable of carrying and switching high currents. Functionally, the two switches mimic a bridge rectifier fed with a direct voltage.

The MAX4684 not only protects the equipment being powered, but also arranges

for an incorrectly polarized battery voltage to be swapped very quickly. The operation of the IC with the correct or the wrong supply polarity is illustrated in Figure 2. For clarity's sake, the current paths are highlighted. With no battery (or battery pack) connected, the two switches are in the 'inactive' position, so that the COM pins are effectively connected to NC (normally closed).

Figure 2a shows the switch positions when the right polarity is applied: control input IN1 (upper switch) is tied to the negative battery terminal and leaves the switch in its inactive position. The lower switch, however, toggles because IN2 is con-

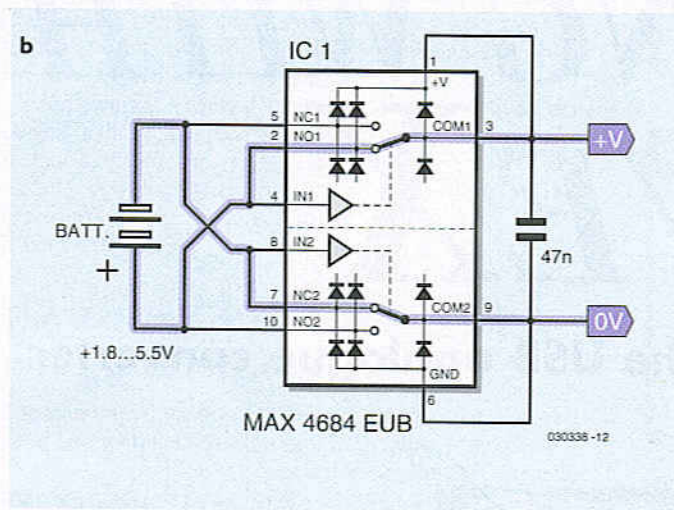

...incorrectly (b) polarized battery.

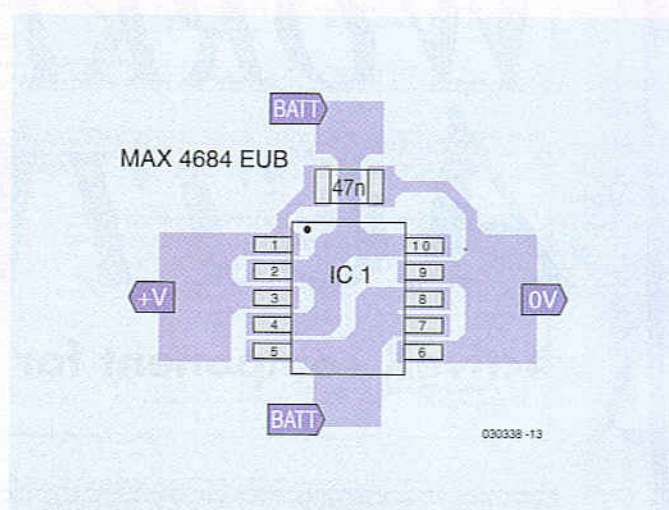

Figure 3. Suggested PCB layout with generous copper areas.

connected to the positive battery terminal. The switch now connects COM2 with NO (normally open), taking the battery negative terminal to the 0 V output.

The other drawing shows the effects of the battery terminals being swapped over. The upper switch changes state, while the lower switch remains in the inactive state.

Internal protection diodes at all inputs and outputs of the chip guarantee that the MAX4684 will always start properly the instant the batteries are inserted into the equipment. Before the relevant switch changes over, both outputs COM1 and COM2 (and with them, +V and ground) are short-circuited. The MAX4684 has a maximum switching time of 60 ns. Within that period, the internal protection diodes provide the supply voltage for the IC itself, independent of the battery polarity. The internal MOSFETs are driven and the switch toggles only when the relevant control input is connected to the positive terminal of a battery supplying at least 1.4 V. Only then does the

correctly polarized battery voltage appear at the chip outputs.

The internal switching MOSFETs are controlled using a certain 'dead time' during which all switch contacts are opened. This so-called break-before-make mode of at least 2 ns prevents a short-circuit on the battery in case the output capacitor is still charged, supplying the IC during a battery change.

As opposed to conducting diodes with their virtually constant voltage drop, the voltage across the MOSFET switches is dependent on the current being passed. At just 0.3 Ω, the $R_{DS(on)}$ specification at $V+ = 1.8 V$ is remarkably low. At 5 V, the switch resistance drops to 0.2 Ω. The two switches and the protection diodes are capable of passing currents up to ±300 mA. The above features make the MAX4684 an excellent choice for lots of equipment running off AA or AAA cells, including portable audio equipment, mobile test and measurement apparatus and cordless telephones.

Table 1 shows the maximum voltage drop across the two switches as compared with silicon and Schottky diodes in a bridge rectifier configuration.

The datasheet of the MAX4684 may be found at

<http://pdfserv.maxim-ic.com/en/ds/MAX4684-AX4685.pdf>

The IC is supplied in a miniature 10-pin μMAX case (3 × 5 mm). For space critical applications, the MAX4684 also comes in an even smaller 'UCSP' case which measures just 1.5 × 2 mm). Figure 3

shows a suggested PCB layout for the MAX case. Finally, it should be noted that the MAX4684 can not be used to rectify alternating voltages.

(030338-1)

Table 1

Comparison between diodes and analogue switches (at 100 mA and 2.4 Vcc)

Component	Voltage drop	Dissipation P_{tot}
4 Si diodes	$2 \times 0.65 V = 1.30 V$	130 mW
4 Schottky diodes	$2 \times 0.40 V = 0.80 V$	80 mW
MAX4684	$2 \times 0.02 V = 0.04 V$	4 mW
2 MAX4624	$2 \times 0.08 V = 0.16 V$	16 mW
2 ADG819	$2 \times 0.05 V = 0.10 V$	10 mW

WORKING WITH ACTIVE X

ActiveX component for the USB analogue converter

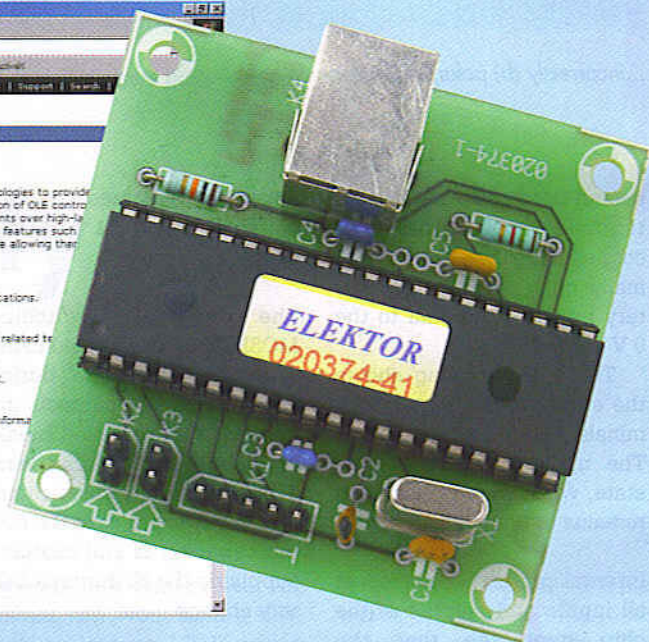
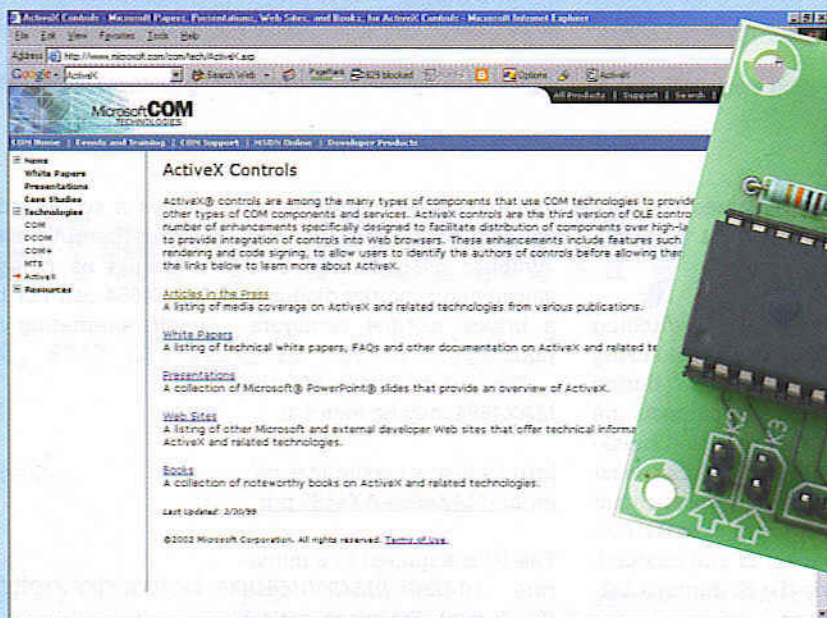

The USB analogue converter published in the November 2003 issue is a neat circuit for simple measurement and test purposes. The ActiveX component described here can be used to control this circuit from a high level language.

Many Elektor Electronics readers constructed this simple circuit, which makes it possible to easily measure analogue voltages and switch digital outputs via USB. Unfortunately, the associated Windows program had a limited functionality and it wasn't always stable. The author was inundated with questions about the program, which led to the development of a utility that allows a user of the USB analogue converter to write a control program for driving any peripheral. The ActiveX component described here can read in analogue values and drive the digital outputs. This type of control makes it possible to program the circuit from within any high

level language, such as Delphi, Visual Basic or C++ by Borland. Since Delphi is one of the most commonly used programming languages, we'll take a look how we can use this language with the ActiveX component.

What is ActiveX?

An ActiveX component is a piece of software that can be used by a host application that incorporates ActiveX control (such as C++Builder, Delphi, Visual dBASE, Visual Basic, Internet

Explorer or Netscape Navigator), and thereby enhances its functionality.

Delphi comes with several ActiveX components for creating graphs, spreadsheets and pictures. You can add these components to the IDE (Integrated Development Environment) and use them just like any other standard VCL element (*Visual Component Library*) by including them in the program and defining their properties with the help of the *object inspector*. You can also use an ActiveX component on a web page by including a link to it in an HTML document and displaying it in a browser that supports ActiveX.

The following is a general method for using an ActiveX component in the Delphi programming environment. We won't include all details for writing ActiveX components. For this we refer you to the *Microsoft Developer's Network (MSDN)*. More information on ActiveX can also be found on Microsoft's website.

The ActiveX component picus_brxProj1.ocx

The author used the original Basic program as the starting point and continued development in Delphi4. It should be clear that the scope of this article doesn't allow for the inclusion of a complete course on the development of ActiveX components. The Help function in Delphi will provide you with the required information.

The complete installation of the ActiveX component requires another seven files. All these files can be found in the folder **fich_ocx** (shown in the screendump in **Figure 1**).

Installation

We'll now go through the installation steps manually, as this makes the process clearer than an automatic installation.

1. The file **picus_brxProj1.ocx** should be copied to the folder **c:\windows\system** for Windows 98/ME, to the folder **c:\windows\system32** for Windows 2000 and XP, or to **c:\WINNT\system32** for Windows 2000 Pro.
2. Copy all other files from folder **fich_ocx** to folder **c:\Program Files\Borland\Delphi\Imports** (the exact folder name can vary slightly, depending on the version of Delphi).
3. Click on Start, Run and type in the command **regsvr32 picus_brxProj1.ocx** (**Figure 2**). When this has finished, you should get the message shown in **Figure 3**.
4. From the *Component* menu in Delphi choose the *Import ActiveX Control* option, then click on **picus_brxProj1**, followed by *Install* and *Save* (**Figure 4**).

When this has completed satisfactorily, the ActiveX component should become visible.

We can now start writing our own driver program.

An example with the ActiveX component

There is nothing clearer than an example to help understand how things work. We'll start with a very simple one: the temperature measurement using the LM335, a well-known temperature sensor made by National Semiconductor.

Its output voltage is proportional to the temperature. This voltage is amplified by a factor of about six by a TL271. The circuit diagram is shown in **Figure 5**. The supply voltage is derived from one of the digital outputs of the USB analogue converter. Output K2 is connected to the first analogue input on the PCB (also K2).

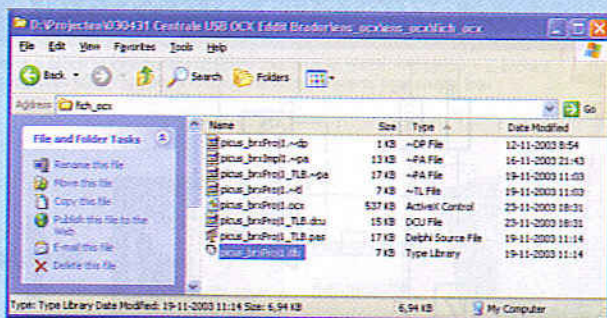

Figure 1. All files for the project are in the folder **fich_ocx**.

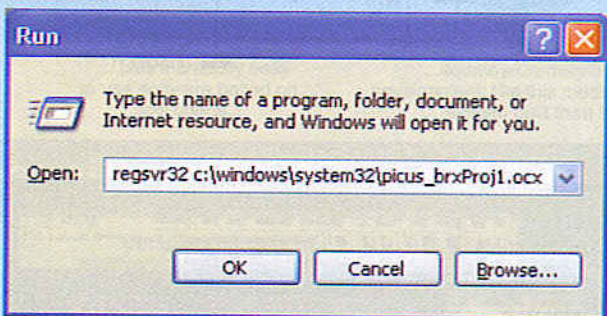

Figure 2. The Run dialogue box, which everybody must surely have used at some stage.

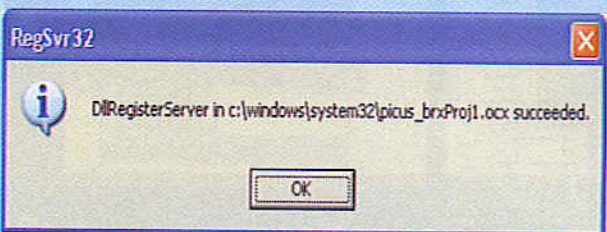

Figure 3. When this message appears the ActiveX component has been correctly registered.

The program

1. Start Delphi, choose File/New Application. Click on the ActiveX tab, then click on the component **picus_brx** and put it onto **Form1** (**Figure 6**).
2. Put a button (found under the standard elements tab of Delphi) onto the form. Then put an edit box (also found under the standard elements tab) onto the form. And finally put a timer (found under the system elements tab) onto the form, as shown in **Figure 7**.

3. Double-click on **Button1** and enter the following code:

```
procedure TForm1.Button1Click(Sender: TObject);
var Val_T:real;
```

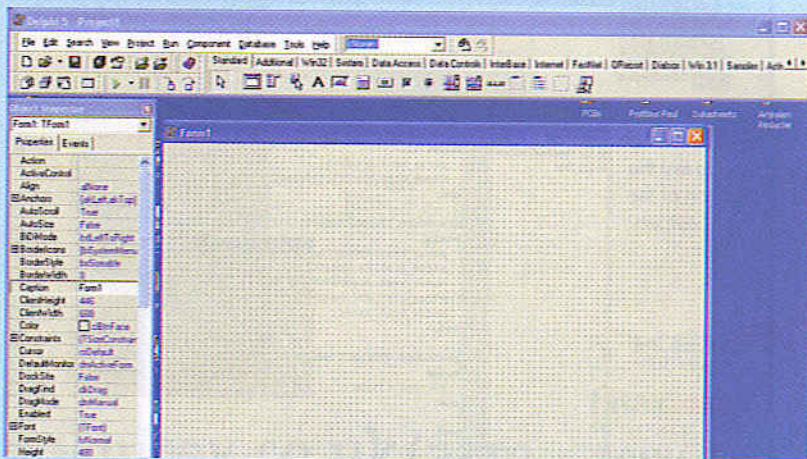

Figure 4. We can now create our own application.

Figure 5. Circuit diagram of a simple thermometer using the well-known LM335.

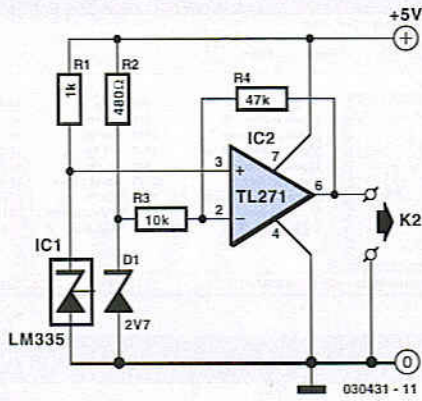

Figure 6. The object 'USB Centrale' has been placed on the form.

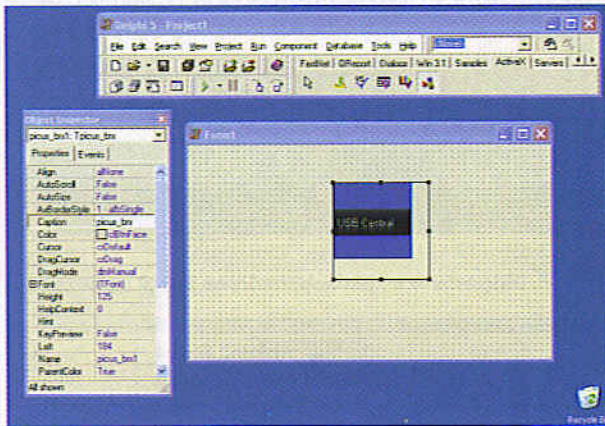

Figure 7. Form1 with Button1, a Timer and an edit box.

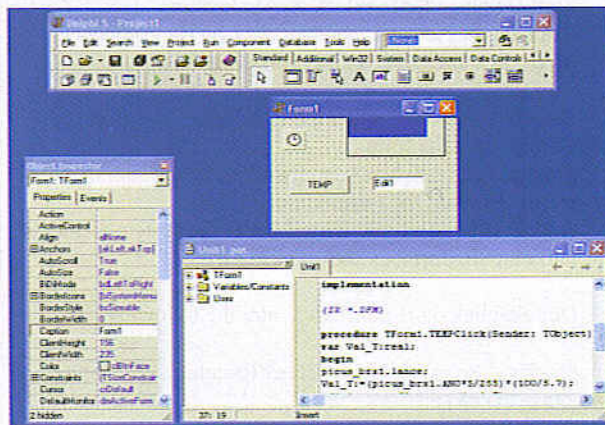
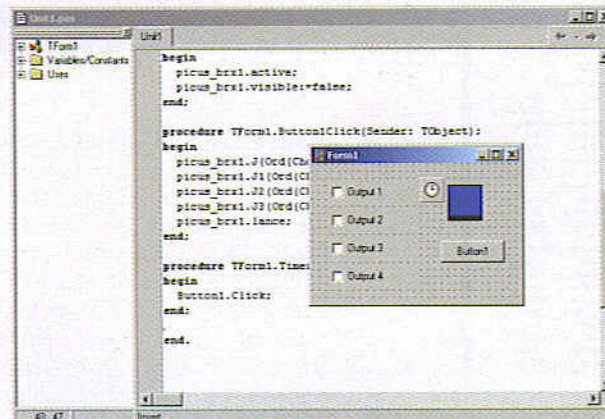

Figure 8. An OCX function can be used to test the operation of the outputs.



```
begin
Val_T:=(picus_brx1.AN0*5/255); {U/T conversion}
Edit1.text:=floattostr(val_T);
end;
```

Double-click on the Timer:

```
procedure TForm1.Timer1Timer(Sender: TObject);
begin
Button1.Click;
end;
```

When you run the program, you should see a temperature-dependent voltage appear on the screen.

Using the outputs

There is a function in the OCX that allows us to control the outputs of the USB analogue converter. We'll use this in the following example.

- Open a new form in Delphi and add the following elements:
- 4 Checkbox elements from the Standard library.
 - 1 Timer from the System library.
 - 1 Button from the Standard library and of course our *picus_brx1* ocx object from the ActiveX library (Figure 8).

Double-click on the Form and type in the following code:

```
procedure TForm1.FormCreate(Sender: TObject);
begin
picus_brx1.active;
picus_brx1.visible:=false;
end;
```

Double-click on Button1 and add:

```
procedure TForm1.Button1Click(Sender: TObject);
begin
picus_brx1.J(Ord(Checkbox1.Checked));
picus_brx1.J1(Ord(Checkbox2.Checked));
picus_brx1.J2(Ord(Checkbox3.Checked));
picus_brx1.J3(Ord(Checkbox4.Checked));
picus_brx1.lance;
end;
```

Double-click on the Timer element and add:

```
procedure TForm1.Timer1Timer(Sender: TObject);
begin
Button1.Click;
end;
```

Click on the Checkboxes and see how the module outputs change their state.

These programs only show a few of the many possibilities that are offered by the USB analogue converter in conjunction with the ActiveX control. We'll leave it up to your imagination to come up with some other uses.

(030431-1)

Web pointers:

ActiveX controls:

www.microsoft.com/com/tech/ActiveX.asp

JEDI Visual Component Library:

<http://homepages.borland.com/jedi/jvcl/>

VCLComponents.com:

www.vclcomponents.com/

Author's website (under construction):

<http://dorelec.web.oo.fr>

For rapid development of electronic systems...

E-BLOCKS™

E-blocks are small circuit boards each of which contains a block of electronics typically found in an electronic system. E-blocks can be programmed in C, Assembly and are tightly integrated with Flowcode - which instantly converts flow charts into PICmicro code.

NEW



Low cost USB PIC programmers
(Starting at £27, model shown £65)

..plus a wide range of add-on boards and accessories...

.....plus incredibly easy to use software based on flow charts...

...equals extremely rapid system development: like this mobile text messaging system built from E-blocks.

...and solutions for learning and development...

Hands on training courses



training courses in PICmicro(R) programming, CPLD programming and ECAD

Resources for learning CPLD programming



Complete courses in electronics and programming

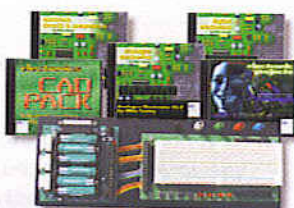

Equipment for datalogging, control and PC 'scopes



...and more at:



...see www.matrixmultimedia.co.uk

Matrix Multimedia Limited
sales@matrixmultimedia.co.uk
t. 0870 700 1831 f. 0870 700 1832

Affordable, Professional ARM7 C/C++ Development!

Everything required for LPC2000 Philips ARM7 development in a single, upgradeable kit.

- ☑ Industry standard Keil uVISION3 IDE, C/C++ compiler and simulator
- ☑ Full Simulation of LPC2000 with peripheral & interrupt support
- ☑ Fully assembled LPC2129 board
- ☑ 16k RAM, 256k FLASH on board
- ☑ Dual CAN and RS232 interfaces
- ☑ JTAG and ETM trace debug interfaces
- ☑ Example program library
- ☑ uLINK USB-JTAG interface (optional)

Basic 16k code development kits from £75 +VAT

Full 16k development kit with JTAG-USB debugger £249+VAT
(Academic price just £149+VAT!)



KEIL SOFTWARE

hitex
DEVELOPMENT TOOLS

PHILIPS

For full details see www.hitex.co.uk/arm

Electronic Switch for Modellers

Electronics instead of mechanics

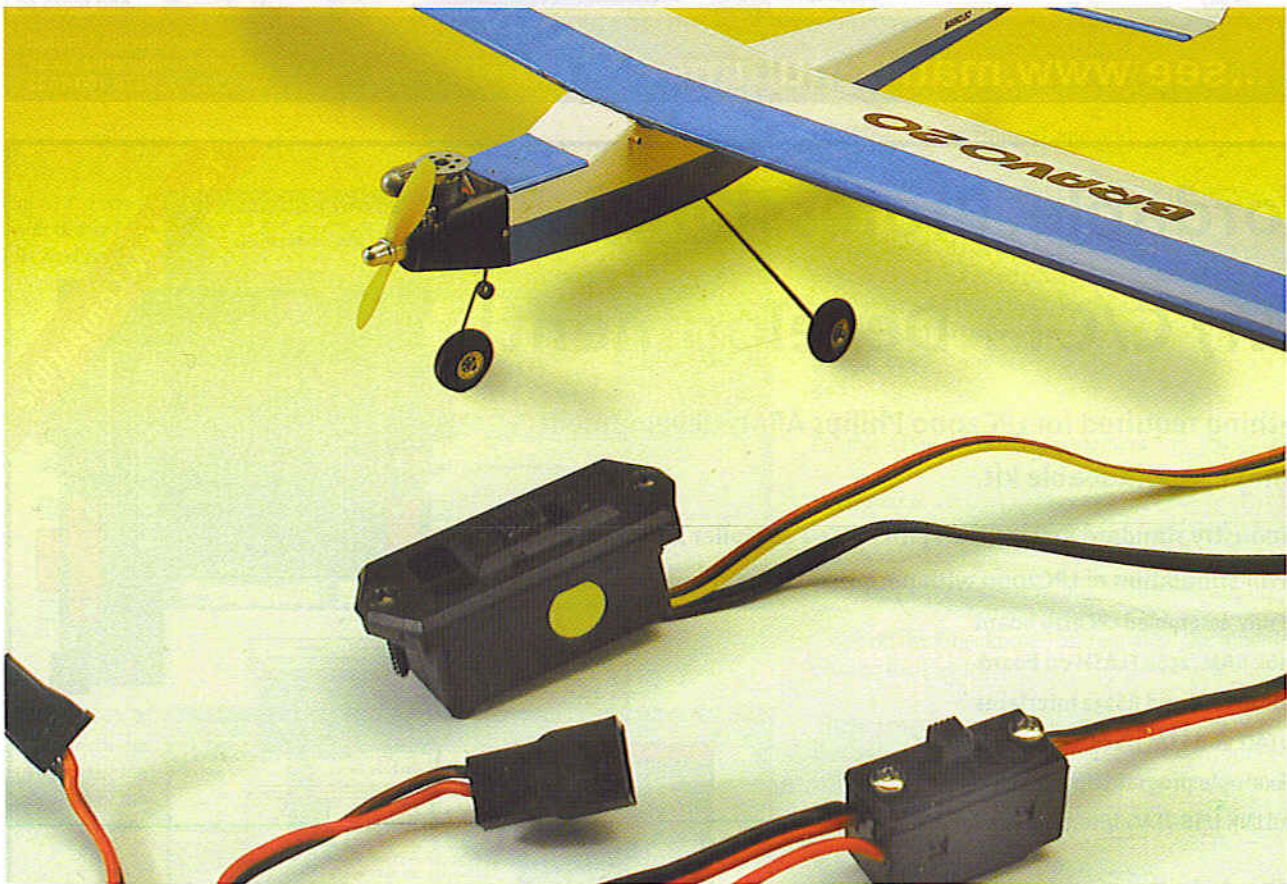

Switching systems in models often suffer from mechanical problems. This electronic replacement is much more reliable and offers a little bit extra!

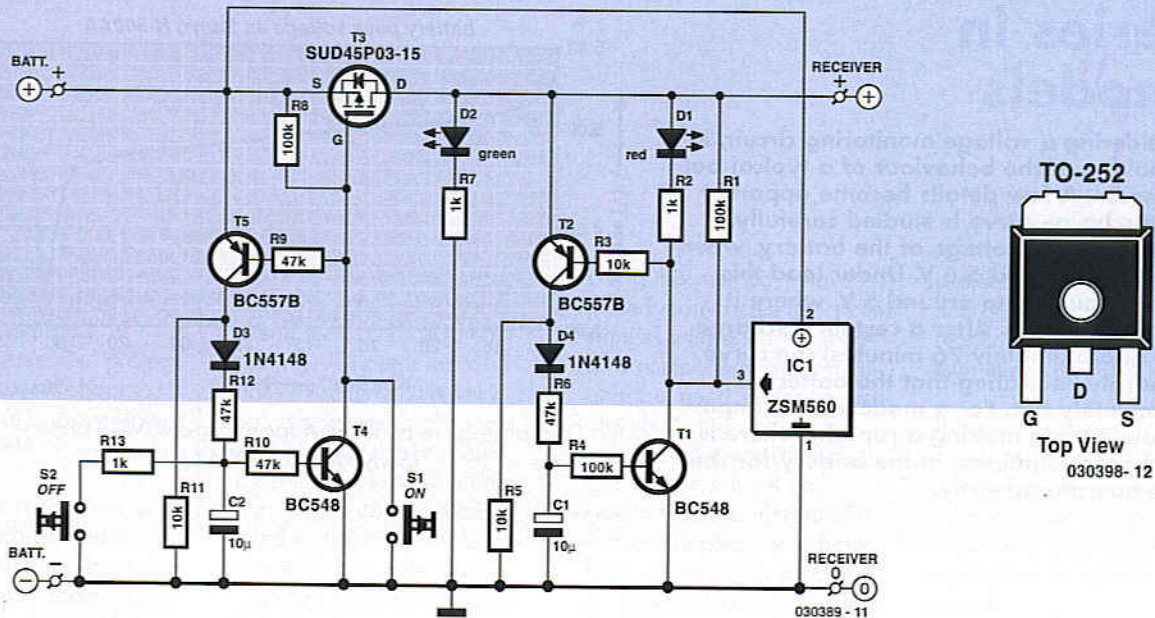

Figure 1. Circuit diagram of the electronic switching system.

Remote-controlled models include many components that, because of their various shortcomings, need to be checked constantly. The scale of the problem is clear from the number of different add-on units that are available from the various manufacturers. Here we present an extremely useful circuit that replaces the (often rather temperamental) switching harness and which also offers a voltage-monitoring function with memory.

Why replace the switch?

Experiments with mechanical switching systems reveal, surprisingly, that they have contact resistances typically between 0.3 Ω and 0.5 Ω . At a peak current of 1 A, which is by no means out of the question with four servos running simultaneously, up to 0.5 V of the supply can be lost in the switching harness alone. Over time, as the connectors and switch contacts become worn and dirty, things can only get worse. It is possible to get around the weaknesses of the mechanical system using modern electronics. In this circuit we use a MOSFET as the switching element, giving an 'on' resistance ($R_{DS(ON)}$) of 0.025 m Ω . It would be practically impossible to achieve such a low value in a mechanical system. The circuit is switched on and off using two tiny pushbuttons, which have considerably less impact on the appearance of a model than a big ugly mechanical switch.

A further advantage is that the supply voltage is continuously monitored, with a permanent indication of any interruption in the supply — and not a microcontroller in sight! The circuit's status is shown by two light-emitting diodes, so that the user can see what is going on at all times.

Requirements

The electronic switching element, which sits between the battery and the receiver and servos, must:

1. be capable of operation at supply voltages as low as 4.5 V;
2. have as low an 'on' resistance as possible;
3. be able to handle currents of up to 5 A without difficulty.

We can satisfy all these requirements using MOSFETs, which are available in a wide range of power ratings. Because we have to deal with low supply voltages of around 4.5 V, the so-called 'logic level' types are the most suitable. At these voltages, ordinary MOSFETs operate more as variable resistors rather than as switches, which leads to a greater voltage drop and considerable power dissipation in the device.

Here we have decided to use the type SUD45P03-15A, a P-channel MOSFET made by Vishay (formerly Siemens). This device is available in a TO-252, or 'DPAK', package and can

handle currents as high as 10 A without difficulty. This makes it ideal for use as a power switch in a model. Its 'on' resistance $R_{DS(ON)}$ is 0.025 m Ω , which means that the voltage dropped across it will be negligible even at high currents.

There are many other types that have the above properties which could be used instead, as a brief glance through the catalogues of component suppliers will reveal.

Switching on and off

The circuit diagram of the electronic switching system is shown in Figure 1. The transistor conducts when its gate is taken to ground by T4. In the non-conducting ('off') state, the gate is taken to a definite (high) voltage level by R8. Green light-emitting diode D2 indicates when the circuit is in the 'on' state.

The circuit is switched to the 'on' state by a brief press on pushbutton S1. This takes the base of T5 to ground, and T5 and T3 conduct. Capacitor C2 charges up and, after a short time, provides a high enough voltage to switch transistor T4. This now takes over the job of pushbutton S1, and so the circuit remains in the 'on' state, even if the user releases the pushbutton.

C2 also allows the circuit to retain its state across brief interruptions of the power supply. When charged, it can supply enough current to the base of T4 to cover an interruption of several seconds. This behaviour can be demonstrated by disconnecting the

Batteries in RC models

When considering a voltage monitoring circuit, it is worth looking at the behaviour of a typical battery in a model. A few details become apparent when the discharge curve is studied carefully. First, the open-circuit voltage of the battery, when fully charged, is around 5.6 V. Under load this falls relatively quickly to around 5 V, where it remains for some time. After a certain discharge time (here approximately 76 minutes) the curve falls off sharply, indicating that the battery is almost completely flat. For a modeller it is important to know, before making a run, that there is sufficient charge remaining in the battery for the receiver to operate correctly.

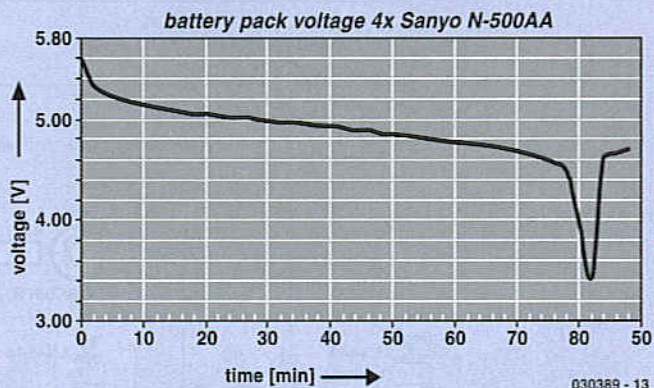

Discharge curve at 300 mA for a four-cell NiCd battery (Sanyo type N-500AA)

battery terminals briefly and then reconnecting them: the green light-emitting diode lights again immediately, without the need to press the button. D3 prevents C2 from discharging rapidly via R11.

The circuit is switched to the 'off' state by pressing pushbutton S2. C2 is discharged and the base of T4 goes to ground potential. T4 stops conducting and then so does the MOSFET T3, since the voltage at its gate is no longer negative with respect to that at its source connection. Resistor R11 prevents a discharged C2 from being charged by leakage currents through T5.

Voltage monitoring

Many ways of monitoring the battery voltage in a remote-controlled model have been proposed. In December 2001 we presented a voltage tester circuit based on an LM3914 that showed the measured voltage on a row of ten LEDs. A disadvantage of that circuit was that the lowest measured voltage was not permanently recorded or displayed.

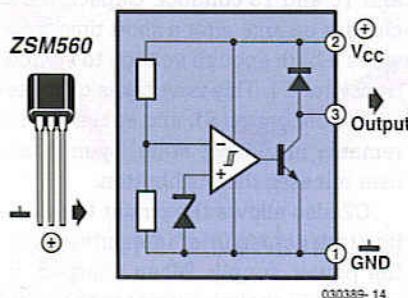

Figure 2. Internal circuit of the ZSM560 reset IC.

In this circuit the battery voltage is monitored using a so-called 'reset IC' (Figure 2), a device which is normally used to provide a reset signal to a microcontroller if the supply voltage falls below a certain threshold. There are many variations available on this theme, the chief difference between devices being in their threshold voltage. If a different threshold value is required, IC1 can be replaced by an appropriate substitute. Make sure, however, that the device has an open-collector output.

Essentially, a reset IC consists of a comparator and a reference voltage generator. The comparator switches when the voltage produced by the integrated potential divider, which consists of two resistors, falls below that produced by the reference generator. The transistor connected to the output of the comparator provides an open-collector output which pulls the output pin low when it is active.

The most important characteristics of the Zetex ZSM560 are as follows:

Maximum supply voltage:	6.5 V
Threshold voltage:	4.6 V ± 0.1 V
Hysteresis:	20 mV typical
Current consumption:	135 mA typical
Maximum output sink current:	60 mA

The reset IC used switches within microseconds and is therefore fast enough to detect reliably even the briefest supply excursions that go below the 4.6 V threshold. Unfortunately, the output goes inactive again once the supply voltage goes back above the threshold: it has no memory function. Here, this function is provided instead by a 'classical' (i.e. microcontroller-free) circuit, connected to the

output of the device.

The memory circuit is essentially the same as that around the main supply switch T3. In this case the reset IC takes the place of the 'on' pushbutton, its output taking the base of T2 to ground when the supply voltage goes below the threshold. This drives T2, and red light-emitting diode D1 lights, signalling to the user that the supply voltage has fallen below 4.6 V. The user should then charge the battery (or possibly check the battery connections).

Construction and use

Construction of the electronic switching system should not present any difficulties. Since the space available in models can vary, we have not provided a printed circuit board layout. The circuit can instead be built on a piece of perforated board cut to a suitable size for the particular application. Ensure that the capacitors and transistors are correctly oriented. The MOSFET is soldered as an SMD device: first tin one pad, then put the transistor in place and solder one lead to the pad. Finally the other two leads can be soldered. Use reasonably thick wire to connect to the battery and to the receiver, since it will have to carry currents of 1 A or more. Precious millivolts of voltage drop can be lost if wire that is too thin is used.

In use, the switching system is very straightforward. Simply connect up the battery and the receiver, and then press the 'on' pushbutton. The green light-emitting diode should light. If the red light-emitting diode does not light, then the model is ready for a run. The circuit is switched off with a brief press of the 'off' pushbutton.

(030389-1)

Project c+ (4) Hands up, who's been a naughty boy then? I am referring, of course, to your 'C+' project. In fact I was just about to order 400 m of expensive Ethernet cable when I suddenly realised that I was reading the April issue of *Elektor* which arrived around April 1st. Nice try, but pulse cannot travel backwards in time, otherwise consider what would happen if you used the leading edge of the received pulse to gate off the pulse generator before the bandpass filters. In that case the pulse would not be sent. If it is not sent then one would not be received at the other end and so there would be nothing to stop the pulse being generated and therefore...

Hang on, I can feel a paradox coming on. Thanks for a great mag though — keep 'm coming.

A. Brammer (psn: Dr. Who)

Glad you did appreciate our April spoof in the end. Discusson closed!

DIY Through-Hole

Plating Dear Sir, first let me congratulate you on the new look *Elektor*. I have been a reader for many years and it is good to see that *Elektor* never rests on its laurels! It has always been the best and likely always will be. One minor glitch; the ink seems to rub off on my sweaty palms! Oh, well. Anyway, down to business. In the "Start Here" guide in April 2004, the issue of through-hole plating for hobbyists is discussed. There is an easy method I use that I find invaluable. Multicore make a system called "Copperset". This is

intended for repairing damaged boards, but is just as useful for DIY through-hole plating. Although the kit is (too) expensive, it is very easy to improvise the tools and just buy the bail bars. Essentially, the system consists of tiny copper tubes filled with solder. These are placed into a hole and snapped off with a special tool (they are scored for 1.6mm thickness boards). The tubes (called bail bars) are £23.81 at Farnell (item 463-929) for 500. That's a lot of holes.

Another special tool is then used to splay out the solder over the ends of the hole and push the sides of the bail into the board. When soldered, the tube becomes a neat, plated hole! All that is then required is to remove the excess solder from it with solder wick.

The 'special tools' I use and my method are as follows:
Tools:

1. Pentel 1-mm automatic pencil, the old mustard-coloured type with a fixed metal nib.
2. Small centre-punch with the tip filed flat.
3. 0.85mm carbide drill bit
4. Desoldering wick

Method:

1. Insert a row of bails into the Pentel
2. One click should protrude exactly one length of bail.
3. Drill holes for plating with the 0.85mm bit.
4. Insert the bail into the hole and snap off.
5. Place the board against a flat metal surface.
6. Use the centre-punch to splay out the top of the bail.
7. Solder top and bottom of bail to surrounding pad.
8. Remove excess solder from hole with wick

Using this method, I have plated many holes for circumstances where the top leads of a component are unavailable but need soldering, usually under big capacitors, power sockets or D-connectors. I have not yet (touch wood) had a single failure. Part of the pleasure I derive from electronics is producing an item that looks professional. This system gives that result at a low cost. I hope this information is of use to your readers.

Rick Fox.

Thanks Rick for your extensive contribution which is printed full length here because I'm sure it contains valuable information for many of our readers.

Serial DLL Dear people at *Elektor*, I am experimenting with the serial port on my PC. I built up the Com Port Tester from the March 2003 issue and downloaded the associated DLL from your website. I noticed that the DLL does not have a START BIT function. Is there a reason for this? If I required a start bit in my protocol how would I generate it using your DLL, or would I have to add a function and recompile the DLL?

Michael (by email)

To comply with the serial communication protocol, the hardware will automatically transmit a start bit, hence a separate button is not required.

Can I build this? Dear *Elektor*, can I please have some information about pace-makers, or indeed anything about heart beat measurement? I am currently doing a

project and seeking information on how to build a pacemaker.

Wei Hing (by mail)

Please, don't even dream of building your own pacemaker, as we would like to see you continue reading our magazine. We appreciate your curiosity but really, this one is best left to the experts.

Display advice Hello, just a note that might help others! 7 segment displays as used in the Digital Alarm Clock in the February 2004 edition are listed as LTS4301E (Liton) these are very hard to find unless you want 500 of them. However, Viewcom, who advertise on page 73 have the equivalent in stock under the part number HD1107O or HD 1107G. Hope this is of some use to others.

Bob Tavener

Thanks Bob, as you can see the word is being passed on.

MailBox Terms

- Publication of reader's correspondence is at the discretion of the Editor.
- Viewpoints expressed by correspondents are not necessarily those of the Editor or Publisher.
- Correspondence may be translated or edited for length, clarity and style.
- When replying to Mailbox correspondence, please quote Issue number.
- Please send your MailBox correspondence to: editor@elektor-electronics.co.uk or *Elektor Electronics, The Editor, P.O. Box 190, Tunbridge Wells TN5 7WY, England.*

David Daamen

TOMI ENGDAHL

the man behind epanorama.net



Photo: Oleg Hartsenko Copyright: Assembly Organizing

Have you got www.epanorama.net bookmarked? If not, you should, because for many years Tomi Engdahl's website has been a highly respected on-line reference work as well as a source of inspiration for many electronics enthusiasts. This time we decided to interview the website maker rather than review his product.

It's hard to think of you having started out with a hobby other than electronics.

I don't remember at what age I started. My father was an engineer and I also got interested in all kinds of technology at an early age. Somehow I got the hang of electronics and yes I also took radios apart as a kid!

At a relatively early age you decided to study Electrical Engineering — did you consider alternative studies or careers?

When I decided to go to Helsinki University of Technology I was not completely sure if I should concentrate on computer science or electrical engineering. I studied in the Department of Computer Science and graduated in that field. I was sure however to select topics that would give me some knowledge of electrical engineering as well. I remember many studies related to signal processing, computer hardware design and data communications were organized by a department called Electrical and Communications Engineering.

Why did you choose Helsinki University?

Today Helsinki University of Technology (HUT) is not actually in Helsinki but in Otaniemi near Espoo, just a few kilometres west of Helsinki. Anyway, my cousin studied there and HUT had a good reputation. It was also just a half hour drive from my home. Later I moved to the campus.

Where you plunged into student life, I suppose?

Sure, for one thing I assisted in organising campus events. One night as I was helping a DJ with the lighting system it turned out that the next DJ wasn't going to show up and I ended up playing records for some time that evening. I got good feedback from the crowd and decided to try again. Later I teamed up with a friend and we gigged at many student parties.

Did the University also trigger your Internet adventures?

Yes, the Internet activities actually started in 1990 but before that I had been active on a BBS for a couple of years. I guess I started writing texts on PC hardware around 1989. I wanted to know more about PC hardware and programming, but there was a lack of information sources and not much material written in Finnish. I then started writing documents collecting and summarising information I found in various sources like PC hardware and component data books. My first texts were written in Finnish and covered PC parallel and serial ports. These texts were updated a few years later.

The epanorama website is also frequently updated. Do you handle the updates yourself?

I used to, but nowadays it's a joint effort. The site change from my personal home page on the University webserver to 'epanorama.net' involved two friends with whom I founded ELH Communications Ltd. Together we had to find a suitable name for the website that was still available to register as a domain name. The name change was effected between 1998 and 1999.

Where is site hosted today?

In the US of A. We employ one primary server from Rackhost and one backup. Although the webhosting company has to be paid for the traffic generated by the site, the facilities offered are generous. For example, we are now able to run scripts, which was impossible on the University webserver. Advertising is used to recover some of our running costs.

Can you give us some web statistics, please?

Sure, at the beginning of 2004 we recorded a daily average of 14,615 visitors browsing 51,562 pages. Total traffic for February 2004 amounted to 67 gigabytes.

The screenshot shows the ePanorama.net website interface. At the top, there's a navigation bar with the site name and a search box. Below that, a 'Content' sidebar lists various categories like Links, Documents, Circuits, Forums, etc. The main area is titled 'ePanorama.net - Links' and contains a large list of categorized links. On the right, there's a 'Site News' section with several entries dated from February 2004 to April 2004, detailing updates and new content.

Impressive and surely an incentive to generate even more traffic?

Time and resources are limiting factors but we strive to add more links, more material to the site's information databases and so on. At the moment the main development is to improve the website administration which will hopefully make updating the site easier and faster. Once things are running smoothly, the database system may also be used for more advanced functions like searching and rating of links. I also have some ideas on how the schematics and documents could be improved so eventually we hope to be able to verify the operation of circuits before they appear on the site, instead of promising amazing things that never happen.

Does your job relate in any way to the website you run?

I work in a company called Netcontrol (www.netcontrol.fi) which develops, markets and supplies monitoring and control systems for energy production and distribution. I also write articles for Prossessori magazine (www.prossessori.fi), for example, a regular feature about good websites I've come across. Updating and extending my own website and writing these articles allows me to use the same link information for both.

So what's in your own Favourites folder then?

Ah well here are just a few pages I bookmarked and visit every day:

- www.google.com (when you need to find something that's not already on www.epanorama.net)
- www.prossessori.fi (admittedly only of interest if you can read Finnish). By the way, Prossessori contains licensed Elektor articles in Finnish!
- www.slashdot.org (for daily computer news)
- www.dilbert.com and www.userfriendly.org (for daily fun)

Finally, what are must-see articles on epanorama.net?

Actually I'm proud of quite a few articles. Maybe 'Ground loop problems and how to get rid of them' deserves a special mention because of the good feedback it received in different forums.

(040130-1)

In all mains-operated equipment certain important safety requirements must be met. The relevant standard for most sound equipment is Safety of Information Technology Equipment, including Electrical Business Equipment (European Harmonized British Standard BS EN 60950:1992). Electrical safety under this standard relates to protection from

- a hazardous voltage, that is, a voltage greater than 42.4 V peak or 60 V d.c.;
- a hazardous energy level, which is defined as a stored energy level of 20 Joules or more or an available continuous power level of 240 VA or more at a potential of 2 V or more;
- a single insulation fault which would cause a conductive part to become hazardous;
- the source of a hazardous voltage or energy level from primary power;
- secondary power (derived from internal circuitry which is supplied and isolated from any power source, including d.c.)

Protection against electric shock is achieved by two classes of equipment.

Class I equipment uses basic insulation; its conductive parts, which may become hazardous if this insulation fails, must be connected to the supply protective earth.

Class II equipment uses double or reinforced insulation for use where there is no provision for supply protective earth (rare in electronics – mainly applicable to power tools).

The use of a Class II insulated transformer is preferred, but note that when this is fitted in a Class I equipment, this does not, by itself, confer Class II status on the equipment.

Electrically conductive enclosures that are used to isolate and protect a hazardous supply voltage or energy level from user access must be protectively earthed regardless of whether the mains transformer is Class I or Class II.

Always keep the distance between mains-carrying parts and other parts as large as possible, but never less than required.

If at all possible, use an approved

mains entry with integrated fuse holder and on/off switch. If this is not available, use a strain relief (Figure, note 2) on the mains cable at the point of entry. In this case, the mains fuse should be placed after the double-pole on/off switch unless it is a Touchproof® type or similar. Close to each and every fuse must be affixed a label stating the fuse rating and type.

The separate on/off switch (Figure, note 4), which is really a 'disconnect device', should be an approved double-pole type (to switch the phase and neutral conductors of a single-phase mains supply). In case of a three-phase supply, all phases and neutral (where used) must be switched simultaneously. A pluggable mains cable may be considered as a disconnect device. In an approved switch, the contact gap in the off position is not smaller than 3 mm.

The on/off switch must be fitted by as short a cable as possible to the mains entry point. All components in the primary transformer circuit, including a separate mains fuse and separate mains filtering components, must be placed in the switched section of the primary circuit. Placing them before the on/off switch will leave them at a hazardous voltage level when the equipment is switched off.

If the equipment uses an open-construction power supply which is not separately protected by an earthed metal screen or insulated enclosure or otherwise guarded, all the conductive parts of the enclosure must be protectively earthed using green/yellow wire (green with a narrow yellow stripe – do not use yellow wire with a green stripe). The earth wire must not be daisy-chained from one part of the enclosure to another. Each conductive part must be protectively earthed by direct and separate wiring to the primary earth point which should be as close as possible to the mains connector or mains cable entry. This ensures that removal of the protective earth from a conductive part does not also remove the protective earth from other conductive parts.

Pay particular attention to the metal spindles of switches and potentiome-

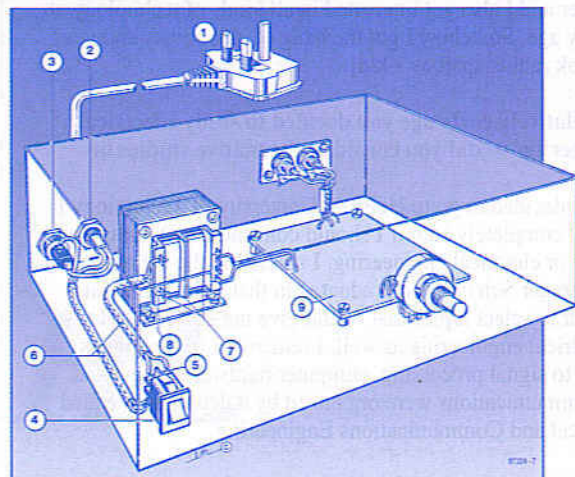

1. Use a mains cable with moulded-on plug.
2. Use a strain relief on the mains cable.
3. Affix a label at the outside of the enclosure near the mains entry stating the equipment type, the mains voltage or voltage range, the frequency or frequency range, and the current drain or current drain range.
4. Use an approved double-pole on/off switch, which is effectively the 'disconnect device'.
5. Push wires through eyelets before soldering them in place.
6. Use insulating sleeves for extra protection.
7. The distance between transformer terminals and core and other parts must be ≥ 6 mm.
8. Use the correct type, size and current-carrying capacity of cables and wires – see shaded table below.
9. A printed-circuit board like all other parts should be well secured. All joints and connections should be well made and soldered neatly so that they are mechanically and electrically sound. Never solder mains-carrying wires directly to the board: use solder tags. The use of crimp-on tags is also good practice.
10. Even when a Class II transformer is used, it remains the on/off switch whose primary function it is to isolate a hazardous voltage (i.e., mains input) from the primary circuit in the equipment. The primary-to-secondary isolation of the transformer does not and can not perform this function.

ters: if touchable, these must be protectively earthed. Note, however, that such components fitted with metal spindles and/or levers constructed to the relevant British Standard fully meet all insulation requirements.

The temperature of touchable parts must not be so high as to cause injury or to create a fire risk.

Most risks can be eliminated by the use of correct fuses, a sufficiently firm construction, correct choice and use of insulating materials and adequate cooling through heat sinks and by extractor fans.

The equipment must be sturdy: repeatedly dropping it on to a hard surface from a height of 50 mm must not cause damage. Greater impacts must not loosen the mains transformer, electrolytic capacitors and other important components.

Do not use dubious or flammable materials that emit poisonous gases. Shorten screws that come too close to other components.

Keep mains-carrying parts and wires well away from ventilation holes, so that an intruding screwdriver or inward falling metal object cannot touch such parts.

As soon as you open an equipment, there are many potential dangers. Most of these can be eliminated by disconnecting the equipment from the mains before the unit is opened. But, since testing requires that it is plugged in again, it is good practice (and safe) to fit a residual current device (RCD)*, rated at not more than 30 mA to the mains system (sometimes it is possible to fit this inside the mains outlet box or multiple socket).

* Sometimes called residual current breaker – RCB – or residual current current breaker – RCCB.

These guidelines have been drawn up with great care by the editorial staff of this magazine. However, the publishers do not assume, and hereby disclaim, any liability for any loss or damage, direct or consequential, caused by errors or omissions in these guidelines, whether such errors or omissions result from negligence, accident or any other cause.

3-core mains cable to BS6500 1990 with three stranded conductors in thick PVC sheath

Max current	3 A	6 A	13 A
conductor size	16/0.2 mm	24/0.2 mm	40/0.2 mm
Nom cond area	0.5 mm ²	0.75 mm ²	1.25 mm ²
overall cable dia.	5.6 mm	6.9 mm	7.5 mm

Insulated hook-up wire to DEF61-12

Max current	1.4 A	3 A	6 A
Max working voltage	1000 V rms	1000 V rms	1000 V rms
PVC sheath thickness	0.3 mm	0.3 mm	0.45 mm
conductor size	7/0.2 mm	16/0.2 mm	24/0.2 mm
Nom cond area	0.22 mm ²	0.5 mm ²	0.95 mm ²
overall wire dia	1.2 mm	1.6 mm	2.05 mm

3-flat-pin mains plug to BS 1363A

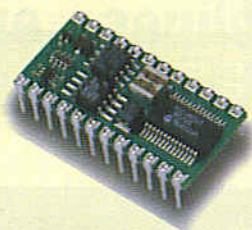

BS2-IC

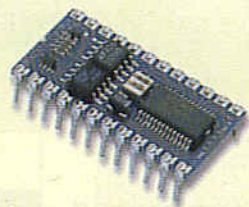

BS2-SX

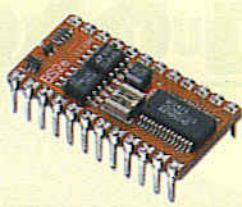

BS2E-IC

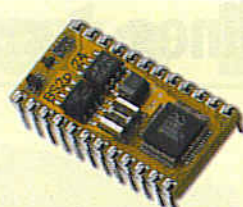

BS2P/24

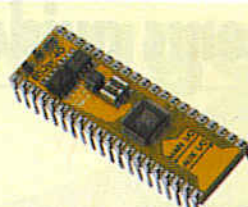

BS2P/40

Parallax BASIC Stamps - still the easy way to get your project up and running!

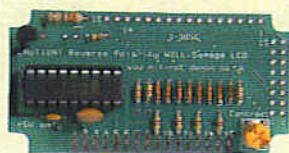

Serial Alphanumeric and Graphic Displays, Mini-Terminals and Bezel kits

www.milinst.com



Animated Head



3-Axis Machine



Six-Legged Walkers

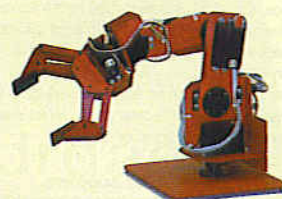

Robotic Arms



Bipeds

Robotic models for both the beginner and the advanced hobbyist

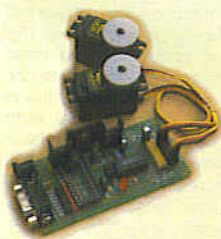

Servo Drivers

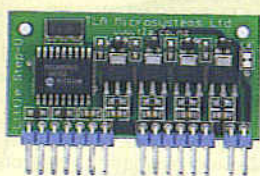

Motor Drivers



On-Screen Displays



DMX Protocol

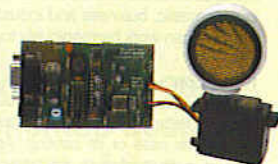

U/Sound Ranging

Animatronics and Specialist Interface-Control Modules



Quadravox MP3 & Speech Systems



SensoryInc Voice Recognition

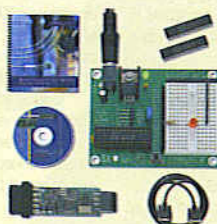

Parallax Ubicom Tool Kits



Tech-Tools PIC & Rom Emulators

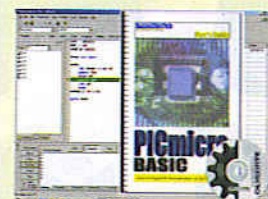

BASICMicro PIC BASIC Compilers

Development Tools

Milford Instruments Limited Tel 01977 683665, Fax 01977 681465, sales@milinst.com

EMC DIRECTIVE

From 1 January 1996, home-made equipment must take into account emc Directive 89/336/EEC (emc = ElectroMagnetic Compatibility). Basically, the directive states that no equipment may cause, or be susceptible to, external interference. Here, interference means many phenomena, such as electromagnetic fields, static discharge, mains pollution in the widest sense of the word.

Legislation

Home-made equipment may be taken into use only when it is certain that it complies with the directive. In the United Kingdom, the dti (Department of Trade and Industry) will, in general, only take action against offenders when a complaint has been made. If the equipment appears not to comply with the directive, the constructor may be sued for damages.



CE label

Home constructors need not affix a CE label to their equipment.

Elektor Electronics and the Directive

The publishers of Elektor Electronics intend that designs published in the magazine comply with the directive. Where necessary, additional guidelines will be given in the article. However, the publishers are neither obliged to do so, nor can they be held liable for any consequences if the constructed design does not comply with the directive. This column gives a number of measures that can be taken to ensure that EE-designed equipment complies with the directive. However, these are needed only in some designs. Other measures, particularly in case of audio equipment, are not new and have been applied for some time.

Why emc?

The important long-term benefit for the user is that all electrical and electronic equipment in a domestic, business and industrial environment can work harmoniously together.

Radiation

The best known form of emc is radiation that is emitted spuriously by an apparatus, either through its case or its cabling. Apart from limiting such radiation, the directive also requires that the apparatus does not impart spurious energy to the mains—not even in the low-frequency range.

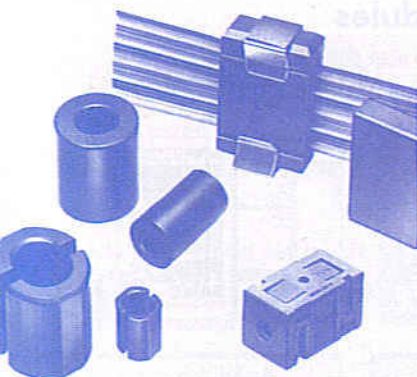

Ferrite through-filters as illustrated are used for feeding cables through a panel.

Immunity

The requirements regarding immunity of an equipment to emc are new. Within certain limits of ambient interference, the apparatus must be able to continue working faultlessly. The requirements are fairly extensive and extend to a wide range of possible sources of interference.

Computers

Computers form the prime group for application of the directive. They, and micro-processors, are notorious sources of interfering radiation. Moreover, owing to the way in which their internal instructions are carried out sequentially, they are also very sensitive to interference. The notorious crash is but one manifestation of this.

Enclosures

A home-made computer system can comply with the emc directive only if it is housed in a metal enclosure. A minimum requirement is that the underside and rear of the enclosure is an I-shaped frame. All cabling must converge on this area or be filtered. If there are connectors on the front panel, a U-shaped metal frame should be used.

Even better results are obtained if a 20 mm wide, 1 mm thick copper strip is fixed along the whole width of the rear wall with screws at 50 mm intervals. The strip should have solder tags at regular distances for use as earthing points.

A closed case is, of course, better than an I-shaped or U-shaped frame. It is important that all its seams are immune to radiation ingress.

Power supplies

In any mains power supply, account should be taken of incoming and outgoing interference. It is good practice to use a standard mains filter whose metal case is in direct contact electrical contact with the enclosure or metal frame. Such a filter is not easily built at home. It is advisable to buy one with integral mains entry, fuse holder and on/off switch. This also benefits electrical safety in general. Make sure that the primary of the filter is terminated into its characteristic impedance—normally a series network of a 50 Ω , 1 W resistor and a 10 nF, 250 V capacitor.

Mains transformers must be provided with RC-networks at the primary and secondary side. Bridge rectifiers must be filtered by RC-networks. The peak charging current into the reservoir capacitor must be limited by the internal resistance of the transformer or by additional series resistors. It is advisable to use a 250 V, 2 W varistor between the live and neutral mains lines. At the secondary side, it is sometimes necessary to use a transient suppressor, preferably following the reservoir capacitor.

If the supply is used with digital systems, a common-mode inductor in the secondary a.c. lines may prove beneficial for limiting radiation. For audio applications, an earth screen between primary and secondary is advisable. This screen must be linked via a short wire with the earthing strip.

The supply must be able to cope with a mains failure lasting four periods and with mains supply variations of +10% and -20%. Peripheral equipment and earthing. All cables to and from peripheral apparatus, such as measurement sensors, control relays, must be fed through the metal wall of the enclosure or frame. The earth lines of such cables must be connected directly to the earthing strip at the inside of the enclosure or frame via a wire not longer than 50 mm. When plugs are used, the cable earth, if any, must be connected to the earth pin or the metal surround of the connector.

Basically, all non-screened signal lines

must be provided with a filter consisting of not less than a 30 mm ferrite bead around the cable or bunch of wires. This bead may be outside the enclosure (for instance, around the PC-to-monitor cable).

Leads that may have a resistance of 150 Ω must be provided with a 150 Ω series resistor at the inside of the connector shell. If technically feasible, there should also be a capacitor from this point to earth. Commercial feed-through T-filters or π -filters may, of course, be used. In all other cases, screened cable must be used for connections within the enclosure. Symmetrical lines must consist of twisted screened cable and be earthed at both ends.

The earth plane of printed-circuit boards must be linked as firmly as feasible with the earthing strip, for instance, via a flexible flat metal strip or flatcable.

Electrostatic discharge (esd)

All parts of an equipment that can be touched from outside must preferably be made from insulating, antistatic material. All parts that can be touched and enter the enclosure, such as potentiometer and switch spindles, must be earthed securely. All inputs and outputs whose wires or connector pins can be touched must be provided with an earth shield, for instance, an earthed metal surround via which any electrostatic discharge are diverted. This is most conveniently done by the use of connectors with sunken pins, such as found in sub-D connectors, and a metal case.

Audio equipment

Immunity to radiation is the most important requirement of audio equipment. It is advisable to use screened cables throughout. This is not always possible in case of loudspeaker cables and these must, therefore, be filtered. For this purpose, there are special high-current T-filters or π -filters that do not affect bass reproduction. Such a filter must be fitted in each loudspeaker lead and mounted in the wall of a metal screening box placed around the loudspeaker connections.

Low-frequency magnetic fields

Screened cables in the enclosure do not provide screening against the low-frequency (< a few kHz) radiation of the mains transformer. Therefore, these cables must run as close as possible to the walls of the enclosure. Moreover, their braid should be linked at one end to the earthing strip. In extreme cases, the power supply should be fitted in a self-contained steel enclosure. Special transformers with a shading ring that reduce the stray field can lower the hum even further.

High-frequency fields

High-frequency fields must not be allowed to penetrate the metal enclosure. All external audio cables must be screened and the screening must be terminated outside the enclosure. This again necessitates the use of all-metal connectors. All cable braids must be linked to the earthing strip inside the enclosure.

Owing to the skin effect, it is important to choose an enclosure with a wall thickness ≥ 2 mm to ensure that internal and external fields are kept separate. Any holes must be either small (<20 mm) or be covered with a metal mesh.

Heat sinks

Heat sinks should preferably be inside the enclosure and be earthed at several points. Non-earthed heat sinks in switch-mode power supplies often create problems. If possible, place an earth screen between transistor and heat sink. Ventilation holes



Standard mains filters built into a mains entry together with an on/off switch. The metal shell must be in firm contact with the enclosure.

must be covered with metal mesh unless they are smaller than 20 mm. Ventilators should be fitted inside the case.

Cables

Cables often function as transmit/receive aerials. This applies equally well to screened cables. The braid of a coaxial cable must be terminated into a suitable connector such that it makes contact along the whole circumference. The braid may be used as the return path to obtain r.f. magnetic screening. For a.f. magnetic screening it is better to use twisted-pair screened cables. In a ribbon (flat) cable, each signal wire should be flanked, if at all possible, by earthed wires. The cable should be screened along one surface or, preferably, all around. Cables that carry signals ≥ 10 kHz that are not filtered in the enclosure, must be provided with a ferrite bead functioning as a common-mode inductance.

Printed-circuit boards

Elektor Electronics printed-circuit boards are provided with coppered fixing holes that are connected to the earth of the circuit. This arrangement, in conjunction with metal spacers, ensures good contact between the board and the circuit earth. Where this is important, boards have a special earth plane that can be connected, where feasible, to the earthing strip via a flatcable. These boards normally have no other earthing points and their fixing holes are, therefore, not coppered.

(960006)

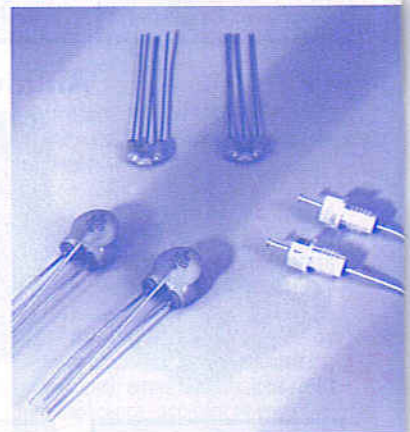

T-filters and π -filters ensure that interference cannot enter from, or enter, the equipment via signal lines. They are available in various current ratings and for various frequency ranges.

DrDAQ Data Logger

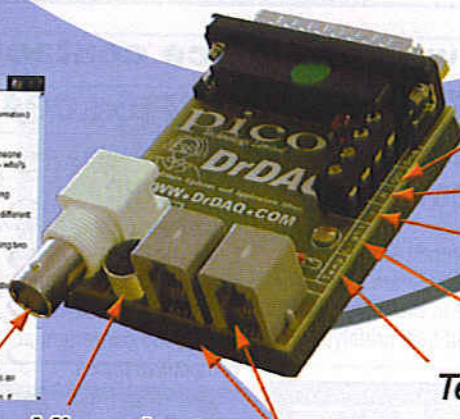
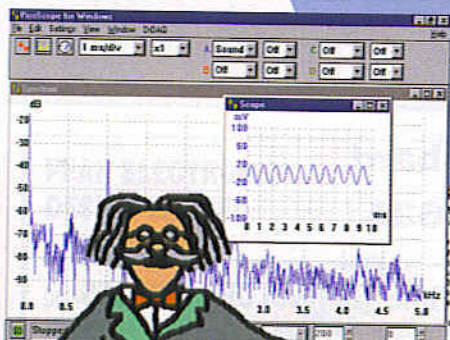

External sensors: Humidity
Temperature
O2 In Air
Reed Switch

- Low cost- under £60
- Built in sensors for light, temperature and sound (level and waveforms)
- Use DrDAQ to capture fast signals
- Outputs for control experiments
- Supplied with both PicoScope (oscilloscope) and PicoLog (data logging) software

For more information on DrDAQ, please visit:

www.picotech.com/drdaq98

PC Oscilloscopes

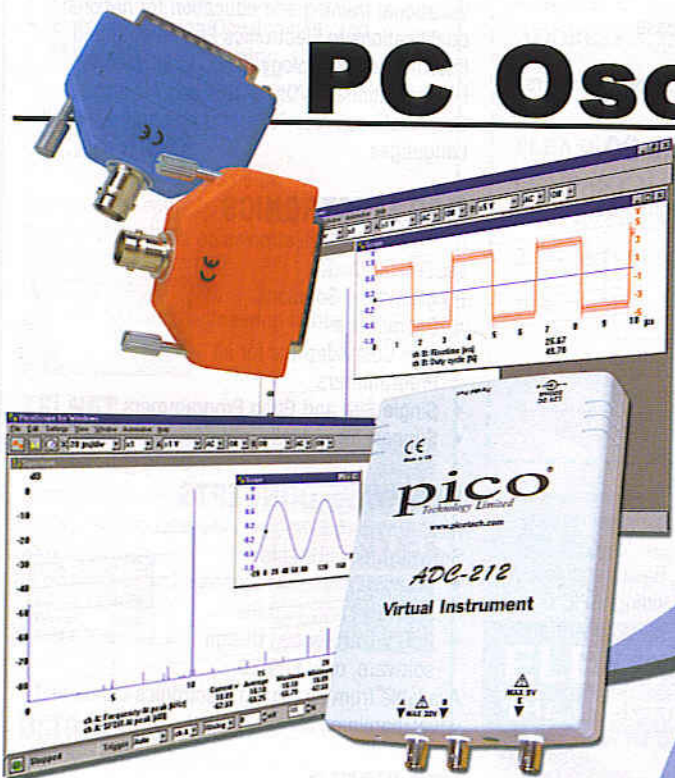

- Scope and spectrum analyser functions
- A fraction of the cost of benchtop scope
- Save multiple setups, for ease of use
- Save, print and e-mail your traces
- FREE technical support for life
- FREE software and upgrades
- Automated measurements

For more information on our scopes, please visit:

www.picotech.com/scope174

Tel: 01480 396395 Fax: 01480 396296 E-mail: sales@picotech.com

PICO
Technology Limited

NET LINKS

To book your website space contact **Bernard Hubbard**

Tel 00 44 (0)1242 510760 Fax: 0044 (0)1242 226626

ALLGOOD TECHNOLOGY

www.allgoodtechnology.com

Low-medium volume sub-contract assembly. SMT specialist since 1990. Customers include military, aerospace etc. 0402 to BGA capabilities, automatic assembly and hand built prototypes.

BETA LAYOUT

www.pcb-pool.com

Beta layout Ltd Award-winning site in both English and German offers prototype

PCBs at a fraction of the cost of the usual manufacturers' prices.



BURN TECHNOLOGY LTD

<http://www.burntec.com>

Test & Measurement Equipment Distributors

- Anemometers • Clamp Meters
- Light Meters • LCR Meters
- Sound Meters • Multimeters
- Device Programmers

Burn Technology Limited, Winfrith Technology Centre, Dorchester, Dorset, DT2 8DH
Tel: (01305) 852090 Fax: (01305) 851940



COMPUCUT

<http://www.compucutters.com>

Computer Numerical Control from your home PC. Great for tricky jobs, and accurate repetitive work. We supply: - Software - Interface - Manual - Support
Price £250 plus postage.

CONFORD ELECTRONICS

<http://www.confordelec.co.uk>

Lightweight portable battery/mains audio units offering the highest technical performance. Microphone, Phantom Power and Headphone Amplifiers. Balanced/unbalanced signal lines with extensive RFI protection.

DANBURY ELECTRONICS

<http://www.mc-h.demon.co.uk/transformers.html>

Here you will find our mains and output transformers in Mike Holme's range of valve/tube amplifiers (PP & SE). Also circuits, parts lists, chassis, advice.

DEBUG INNOVATIONS UK

<http://www.debuginnovations.com>

Introducing hassle free prototyping

- RF / Analogue
- High speed digital
- Surface mount
- 0.1" grid
- Power planes
- Unique patch architecture

Forget custom PCBs, start your project now!



EASYSYNC

<http://www.easysync.co.uk>

EasySync Ltd sells a wide range of single and multi-port USB to RS232/RS422 and RS485 converters at competitive prices.



ELEXOL PTY LTD

<http://www.elexol.com>

Developer and manufacturer of

- USB Development Modules.
- USBMOD Series.
- USBIO24 Digital Input/Output Module.
- MP3 Solutions.
- MP3MOD4 Module.

Distributor inquiries welcome.



ELNEC

www.elnec.com

- device programmer manufacturer
- selling through contracted distributors all over the world
- universal and dedicated device programmers
- excellent support and after sale support
- free SW updates
- once a months new SW release
- reliable HW
- three years warranty for most programmers



ERVAN INTERNATIONAL CO.

<http://www.ervan-int.com>

Power Electronics and Solar Energy Design and Consultants. Also offers; Discount prices of:

- Ultra Bright LEDs
- PCB LED Cluster Kits
- Laser Pointers
- Solar Modules
- Batteries

FOREST ELECTRONIC DEVELOPMENT

<http://www.fored.co.uk>

FED supply PIC programmers, Basic modules, and development software including a PIC C Compiler, Prog 'n Drop Visual Development and a well featured debugging environment.

FUTURLEC

<http://www.futurlec.com>

Save up to 60% on

- Electronic Components
- Microcontrollers, PIC, Atmel
- Development Boards, Programmers

Huge range of products available on-line for immediate delivery, at very competitive prices.



FUTURE TECHNOLOGY DEVICES

<http://www.ftdichip.com>

FTDI designs and sells USB-UART and USB-FIFO interface i.c.'s.

Complete with PC drivers, these devices simplify the task of designing or upgrading peripherals to USB

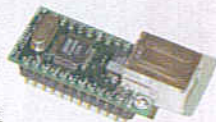

HAMMOND ELECTRONICS

<http://www.hammondmfg.com>,

sales@hammond-electronics.co.uk

tel: 01256 812812.

Small die-cast, plastic and metal enclosures for the hobbyist and professional. Widely available from major distributors.



KOMCARD

www.komcard.com

Learn how to design a PCI card, and write a PCI device driver. We lead you step by step with practical PCI projects you build.

LONDON ELECTRONICS COLLEGE

<http://www.lec.org.uk>

Vocational training and education for national qualifications in Electronics Engineering and Information Technology (BTEC First National, Higher National NVQs, GCSEs and Advanced Qualifications). Also Technical Management and Languages.

MQP ELECTRONICS

<http://www.mqpelectronics.co.uk>

Leaders in Device Programming Solutions.

- Online shop
- Low Cost Adapters for all Programmers
- Single Site and Gang Programmers
- Support for virtually any Programmable Device



NEW WAVE CONCEPTS

<http://www.new-wave-concepts.com>

Software for hobbyists:

- Livewire circuit simulation software, only £29.36
- PCB Wizard circuit design software, only £29.36

Available from all Maplin Electronics stores and www.maplin.co.uk



PCB WORLD

<http://www.pcbworld.org.uk>

World-class site: Your magazine project or prototype PCB from the artwork of your choice for less. Call Lee on 07946 846159 for details. Prompt service.

PEAK ELECTRONIC DESIGN LIMITED

www.peakelec.co.uk

Cool component test gear for your passives and semis. Instant identification, measurement and validation. Connect anyway round. The Peak Atlas family starts from £59.



QUASAR ELECTRONICS

www.QuasarElectronics.com

Over 300 electronic kits, projects and ready built units for hobby, education and industrial applications including PIC/ATMEL programming solutions. Online ordering facilities.

Tel: +44 (0) 870 246 1826

Fax: +44 (0) 870 460 1045

Email: sales@QuasarElectronics.com



ROBOT ELECTRONICS

<http://www.robot-electronics.co.uk>

- Ultrasonic rangefinders
- Motor H-Bridge controllers
- Magnetic Compasses
- RC servos and controllers
- PIC programmers and components
- Electronic Design/Development and Manufacturer to industry



TECHNOBOTS

<http://www.technobots.co.uk>

Welcome to Technobots - the one stop shop specially for the remote operated robot builder, radio control and engineering hobbyist.



TELNET

<http://www.telnet.uk.com>

The site shows graphically Telnets wide range of quality second-user test and measurement equipment, including oscilloscopes and spectrum analysers.



ULTRALEDS

<http://www.ultraleds.co.uk>

tel: 0871 7110413

Large range of low cost Ultra bright leds and Led related lighting products. Major credit cards taken online with same day despatch.

USB INSTRUMENTS

<http://www.usb-instruments.com>

USB Instruments specialises in PC based instrumentation products and software such as Oscilloscopes, Data Loggers, Logic Analysers which interface to your PC via USB.



VIEWCOM

<http://www.viewcom.f9.co.uk>

tel: 020 8471 9338 fax: 020 8552 0946

- Mail Order supplier of:
 - Integrated Circuits and Components.
 - Kit and parts for Elektor projects.
 - Transistors, FETs, Capacitors, Resistors, Crystals, etc and hard to find devices.
- Viewcom Electronics, 77 Upperton Road West, Plaistow, London E13 9LT

PROMOTE YOUR WEBSITE HERE

Elektor Electronics have a feature to help customers to promote their websites, Net Links - a permanent feature of the magazine where you will be able to highlight your site on a regular basis.

- For just £120 + VAT (£10.90 per issue for eleven issues) Elektor will publish your company name, a 25-word description and your website address.
- For £300 + VAT for the year (£27.27 per issue for eleven issues) we will publish the above plus run a 3cm deep full colour screen shot from your site.

Places are limited and spaces will go on a strictly first come, first served basis, please fax back your order today!

I wish to promote my company, please book my space:

- Text insertion only for £120 + VAT
- Text and photo for £300 + VAT

NAME: ORGANISATION:

JOB TITLE:

ADDRESS:

..... TEL:

PLEASE COMPLETE COUPON BELOW AND FAX BACK TO 00-44-(0)1242 226626

COMPANY NAME

WEB ADDRESS

25-WORD DESCRIPTION

.....

.....

.....

.....

.....

ELECTRONIC ENTHUSIASTS

Only one magazine tests its projects and circuits in its own lab before publication -

ELEKTOR ELECTRONICS

THE ELECTRONICS & COMPUTER MAGAZINE



Contact: Worldwide Subscription Service Ltd,
Unit 4 Gibbs Reed Farm, Pashley Road, Ticehurst
TN5 7HE Telephone: (+44) (0) 1580 200657
Fax: (+44) (0) 1580 200616 Or visit our Website:
www.elektor-electronics.co.uk

Please Note

Software items marked © are available from the Free Downloads page of the Publishers' website at www.elektor-electronics.co.uk. Diskettes are supplied for the convenience of readers without Internet access.

EVERGREENS

	£	US \$
Elektor Electronics Help Disk		
966022-1 Disk, Windows version	8-15	14.45
Elektor Electronics Item Tracer 1985-2003		
046003-11 contents database (disk, Windows version)	8-15	14.35
Universal Prototyping Boards		
UPBS-1 PCB	2-45	4.30
UPBS-2 2 PCBs	4-10	7.25
UPBS-4 4 PCBs	6-55	11.55

no.334 JULY/AUGUST 2004

	£	US \$
IR Servo Motor Interface		
© 020356-11 Disk, RCX program and PIC source & object code	4-90	8.65
020356-41 PIC16F628, programmed	10-00	17.70
020356-42 PIC16F628, programmed	10-00	17.70
Micro Webserver with MSC1210 Board		
030060-91 Microprocessor Board, ready-assembled	69-00	112.50
044026-91 Network Extension Board, ready-assembled	41-95	73.95
044026-92 Combined package (030060-91 + 044026-91 and all related articles)	103-50	
184.95		
© 044026-1 Network Extension Board, PCB only	10-45	18.50
R/C Analyser		
© 030178-11 Disk, PIC source code	4-90	8.65
030178-41 PIC16F627-4/CP, programmed	10-25	18.15
USB Converter Controlled via HTML		
© 044034-11 Disk, example programs	4-90	8.65

no.333 JUNE 2004

	£	US \$
Multi Programmer		
© 020336-1 PCB	8-60	15.60
© 020336-11 Disk, firmware & source code	4-90	8.65
Pocket Pong		
© 030320-11 Disk, PIC software	4-90	8.65
Rail Router		
© 030403-1 PCB	10-80	19.15
© 030403-11 Disk, PIC & PC software	4-90	8.65
© 030403-41 PIC16F877-20/P, programmed	21-45	37.95
Smooth Operator		
© 030209-11 Disk, PIC software	4-90	8.65
030209-41 PIC16F84-10P, programmed	14-70	26.00

no.332 MAY 2004

	£	US \$
Design Your Own IC		
© 030385-1 PCB	15-65	27.70
High-End Preamp		
© 020046-1 PCB — main board	8-45	14.95
© 020046-2 PCB — relay board	7-50	13.30
© 020046-3 PCB — PSU board	6-70	11.85
© 020046-11 Disk	4-90	8.65
020046-41 PIC18LF452-4/L, programmed	28-20	49.90
Wind Speed & Direction Meter		
© 030371-11 Disk, project software	4-90	8.65
030371-41 PIC16F871, programmed	17-55	31.05

no. 331 APRIL 2004

	£	US \$
Drop-in Microcontroller Board		
© 020148-1 PCB	8-60	15.20
© 020148-11 Disk, sample project file	4-90	8.65
Pandora's Sound & Music Box		
© 030402-1 PCB	10-60	18.75

GENERAL

Printed-circuit boards (PCBs), self-adhesive front panel foils, ROMs, EPROMs, PALs, GALs, microcontrollers and diskettes for projects which have appeared in *Elektor Electronics* may be ordered using the Order Form printed opposite. The form may also be used to order books (private customers only).

» The artwork for making a PCB which is not available ready-made through the Readers Services may be found in the relevant article.

» EPROMs, GALs, PALs, (E)PLDs, MACHs, PICs and other microcontrollers are supplied ready-programmed.

Prices and item descriptions subject to change. The publishers reserve the right to change prices without prior notification. Prices and item descriptions shown here supersede those in previous issues. E. & O.E

PAST ISSUES

Past issues, if available, should be ordered from **Worldwide Subscription Service Ltd, Unit 4, Gibbet Reed Farm, Pashley Road, TICEHURST TN5 7HE, England, telephone (+44) 1580 200657, fax (+44) 1580 200616, email wsss@wsss.demon.co.uk**. Prices of past issues (except July/August and December), including postage for single copies, are £4.75 (UK and Eire); £5.30 (air mail Europe); £6.10 (airmail outside Europe). Prices of past July/August and December issues, including postage for single copies, are £6.65 (UK and Eire); £7.35 (airmail Europe); and £8.45 (airmail outside Europe).

PAST ARTICLES

For information on past articles, please contact our Editorial and Administrative Offices, telephone (01580) 200657; fax 200616, email sales@elektor-electronics.co.uk.

	£	US \$
© 030402-11 Disk, source and hex code files	4-90	8.65
030402-41 PIC16F871/R, programmed	20-55	36.40

VHF-Low Explorer

© 020416-1 PCB	8-80	15.50
----------------	------	-------

No. 330 MARCH 2004

Build Your Own DRM Receiver

© 030365-1 PCB	9-10	16.10
© 030365-11 Disk, DRM.exe program	4-90	8.65

Code Lock

© 020434-1 PCB	9-60	16.95
© 020434-11 Disk, source & hex code files	4-90	8.65
020434-41 Pic16F84A-4P, programmed	14-70	26.00

Hands-on CPLDs (2)

© 030052-1 PCB	8-90	15.75
© 030052-11 Software	4-90	8.65
030052-41 EPM7128SLC84-15, programmed	33-40	59.10

Multichannel Failsafe for Radio Controlled Models

© 020382-11 Disk, source code file	4-90	8.65
020382-41 AT89C52-24/JI, programmed	8-70	15.40

Multifunction Frequency Meter

© 030136-1 PCB	9-35	16.55
© 030136-11 Disk, project software	4-90	8.65
030136-41 AT90S2313-10PC, programmed	7-95	14.05

No. 329 FEBRUARY 2004

Digital Alarm Clock

© 030096-11 Disk, PIC source and hex code	4-90	8.65
030096-41 PIC16F84-04/p, programmed	15-20	26.90

iAccess

© 020163-11 Disk set, source code and control software	7-50	13.30
020163-41 AT89S8252-12PC, programmed	13-90	24.60

Simple 12-to-230V Power Inverter

© 020435-1 PCB	8-50	15.05
----------------	------	-------

Touch-controlled Switch

© 030214-11 Disk, PIC source code	4-90	8.65
030214-41 PIC12C508AD-4/S08, programmed	6-15	10.90

No. 328 JANUARY 2004

64-K 80C552 Flash Board

© 030042-1 PCB	9-35	16.55
© 030042-11 Disk, misc. project software	4-90	8.65
030042-21 29F010, programmed	10-00	17.70
030042-31 GAL 16V8D15QP, programmed	6-10	10.80

Climate Logger



Prototypes and small series up to 1000 pcs

Value for Money

Up to 6 layer boards

Always Available

Attractive price

www.ThePCBSHOP.com

On-line Printed Circuit Boards

Double Sided, 1.6 mm,

Plated Through,

Green Solder mask,

Hot Air Level,

1 White Legend.

Price including

tooling + plotting + VAT

100 mm x 160 mm
1 pc = 45.74 Euro

100 mm x 80 mm
5 pcs = 68.97 Euro

	£	US \$
@ 030076-1 PCB	7-75	13.70
@ 030076-11 Disk, Windows software	4-90	8.65
FMS Flight Simulator Encoder		
@ 030066-1 PCB	10-20	18.05
030066-41 87LPC767BN, programmed	17-05	30.15
LED Roulette		
@ 030168-1 PCB	17-90	31.60
@ 030168-11 Disk, source and hex files	4-90	8.65
030168-41 89C2051-12PC, programmed	8-05	14.25
Multi-event Alarm Clock		
@ 020304-11 Disk, C (source) hex files	4-90	8.65
020304-41 AT89C2051-12PC, programmed	6-10	10.80
Stepper Motors Uncovered		
020127-41 PIC16F873-20/SP	19-10	33.80

No. 327 DECEMBER 2003

FM Remote Control Transmitter & Receiver		
@ 034044-1 PCB	10-20	18.05
LED Christmas Decoration		
@ 030157-1 PCB	7-55	13.35
P87LPC76x Programmer		
@ 030313-11 Disk, project software	4-90	8.65
Project Timekeeper		
@ 020350-11 Disk, source & object code files	4-90	8.65
020350-41 PIC16F84-10P, programmed	13-15	23.25
Stepper Motors Uncovered (2)		
@ 020127-11 Disk, source code file	4-90	8.65
Universal Clock Generator		
@ 020395-11 Disk, source code file	4-90	8.65
Wireless RS232 Link		
@ 030204-1 PCB	8-70	15.40

No. 326 NOVEMBER 2003

Precision Measurement Central		
@ 030060-4 PCB	8-70	15.40

No. 326 NOVEMBER 2003

Rev Counter for R/C Models		
@ 024111-1 PCB	17-50	31.00
024111-11 Disk, source and hex code	4-90	8.65
024111-41 89C2051-12PC, programmed	8-85	15.65
Running Text Display		
@ 020407-11 Disk, source and hex code	4-90	8.65
USB Analogue Converter		
@ 020374-1 PCB	7-65	13.50
@ 020374-11 Disk, hex code and Windows software	4-90	8.65
020374-41 PIC16C765, programmed	13-25	23.45

No. 325 OCTOBER 2003

DDS RF Signal Generator		
@ 020299-1 PCB, generator	11-60	20.55
@ 020299-2 PCB, control/supply	12-10	21.45
020299-41 AT90S8515 8PC, programmed	30-55	54.05
Minimalist Induction-Balance Metal Detector		
@ 020290-1 PCB	8-95	15.85
Xilinx PROM Programmer		
@ 010109-11 Software	4-90	8.65

No. 324 SEPTEMBER 2003

ATV Picture Generator		
@ 020295-11 Disk, source & hex code files	4-90	8.65
020295-41 AT90S8515-8PC, programmed	15-20	26.90
020295-42 AT90S1200-12PC, programmed	13-90	24.60
DTMF Remote Telephone Switch		
@ 020294-1 PCB	11-65	20.60
@ 020294-11 Disk, project software	4-90	8.65
020294-41 PIC16F84A-20/P, programmed	14-70	26.00

LC Display with I²C Bus

@ 030060-2 PCB	7-35	13.00
PICProg 2003		
@ 010202-1 PCB	9-05	16.00
@ 010202-11 Disk, Windows software	4-90	8.65
010202-41 PIC16F874-20/P, programmed	23-55	41.65

Polyphonic Doorbell

@ 020354-11 Disk, project software	4-90	8.65
020354-41 PIC16F84A-10/P, programmed	14-45	25.55

Precision Measurement Central

030060-91 Ready-assembled & tested board	69-00	112.50
--	-------	--------

Valve Pre-amplifier (1)

@ 020383-1 PCB, amplifier board	11-55	20.40
@ 020383-2 PCB, power supply board	11-40	20.20
@ 020383-3 PCB, I/O board	10-10	17.80

No. 323 JULY/AUGUST 2003

Add a Sparkle

@ 020293-11 Disk, HEX and source files	4-90	8.65
020293-41 PIC12C509A-04/SM, programmed	7-40	13.10

	£	US \$
AT90S2313 Programmer		
@ 034036-1 PCB	9-05	16.00
Hard Disk Selector		
@ 034050-1 PCB	9-45	16.75
Mini Running Text Display		
@ 020365-11 Disk, source code file	4-90	8.65
Mini Test Chart Generator		
@ 020403-11 Disk, PIC source code	4-90	8.65
Programming Tool for AtTiny15		
@ 030030-1 PCB	7-55	13.35
@ 030030-11 Disk, project software	4-90	8.65
Quad Bridge Car Amp		
@ 034039-1 PCB	8-70	15.35
Remote Light Control with Dimmer		
@ 020337-11 Disk, HEX and source files	4-90	8.65
020337-41 AT89C2051-12, programmed	6-25	11.05

No. 322 JUNE 2003

AVR TV Tennis		
@ 030026-1 Main PCB	8-70	15.40
@ 030026-2 Pushbutton PCB	8-60	15.25
@ 030026-11 Disk, AVR source code	4-90	8.65
030026-41 AT908515, programmed	15-20	26.90
Electronic Knotted Handkerchief		
@ 020308-11 Disk, PC and controller software	4-90	8.65
020308-41 AT90S2313-10PC, programmed	12-60	22.30
Low-Cost LCD Controller (2)		
@ 020114-1 PCB	8-70	15.35
@ 020114-11 Disk, project software	4-90	8.65
Night Light Control		
@ 020115-11 Disk, hex and source code	4-90	8.65
020115-41 AT90S2313-10PC, programmed	12-85	22.75
Universal XA Development Board		
@ 010103-1 PCB	13-20	23.35
@ 010103-11 Disk, GAL code, EPROM hex files, XADEV	4-90	8.65
010103-21 EPROM IC8, 27C256-90, programmed	10-00	17.70
010103-22 EPROM IC9, 27C256-90, programmed	10-00	17.70
010103-31 GAL 16V8, programmed	4-80	8.50

No. 321 MAY 2003

Countdown Timer		
@ 020296-11 Disk, source and hex code	4-90	8.65
020296-41 AT90S1200, programmed	13-90	24.60
USB Audio Recorder		
@ 012013-11 Disk, EPROM hex code	4-90	8.65
012013-21 EPROM 27C512, programmed	12-60	22.30
Valve Final Amp (2)		
@ 020071-1 Amplifier board (one channel)	15-10	26.75
@ 020071-2 Power supply board	10-05	17.75

No. 320 APRIL 2003

8-Channel Disco Light Controller		
@ 010131-1 PCB	13-10	23.15
010131-41 87C750 or 87C71, programmed	23-00	40.70
Pico PLC		
@ 010059-1 PCB	18-70	33.10
@ 010059-11 Disk, test program	4-90	8.65
Single-Chip Tone Control		
@ 020054-4 PCB	10-90	19.30
Switched-Outlet Power Bar with RS232 Control		
@ 020298-1 PCB	10-80	19.10
@ 020298-11 Disk, project software	4-90	8.65
Temperature Indicator for the PC		
@ 020380-11 Disk, source and compiled code	4-90	8.65
020380-41 AT89C2051, programmed	10-25	18.15

No. 319 MARCH 2003

17 V / 10 A Switch-Mode Power Supply		
@ 020054-3 PCB	9-45	16.65
Add-on Switch unit for R/C Models		
@ 020126-1 PCB	8-95	15.85
@ 020126-11 Disk, hex and source files	4-90	8.65
020126-41 PIC16C712-041/SO, programmed	15-20	26.90
AVRee Development System		
@ 020351-1 PCB	13-20	23.35
@ 020351-11 Disk, example programs	4-90	8.65
Guitar Effects Switchbox		
@ 020181-1 PCB	13-15	23.30
Intelligent Fan Timer		
@ 020170-11 Disk, project software	4-90	8.65
020170-41 MSP430F1121, programmed	11-30	20.00

Products for older projects (if available) may be found on our web site
<http://www.elektor-electronics.co.uk>

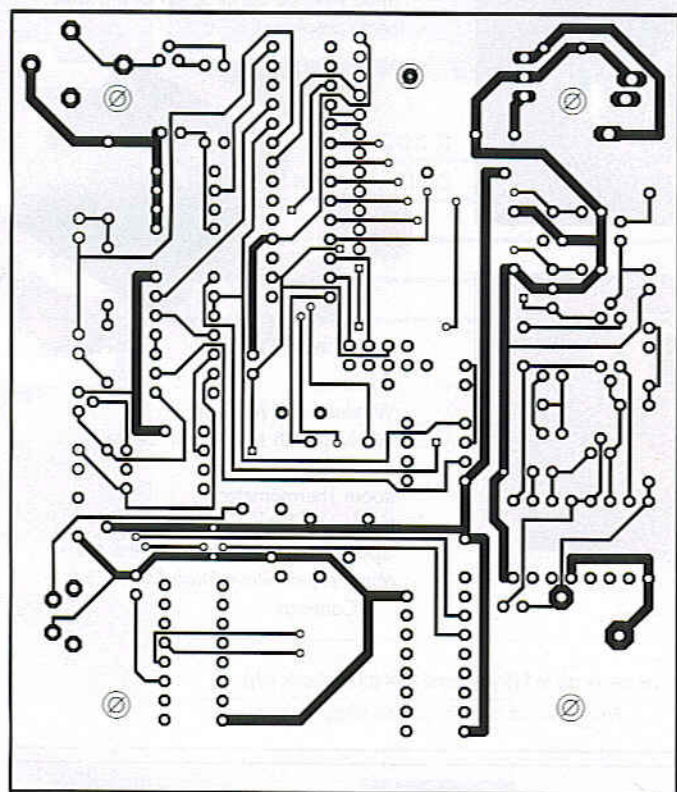

TV Commercials Killer 040051-1 (solder side)

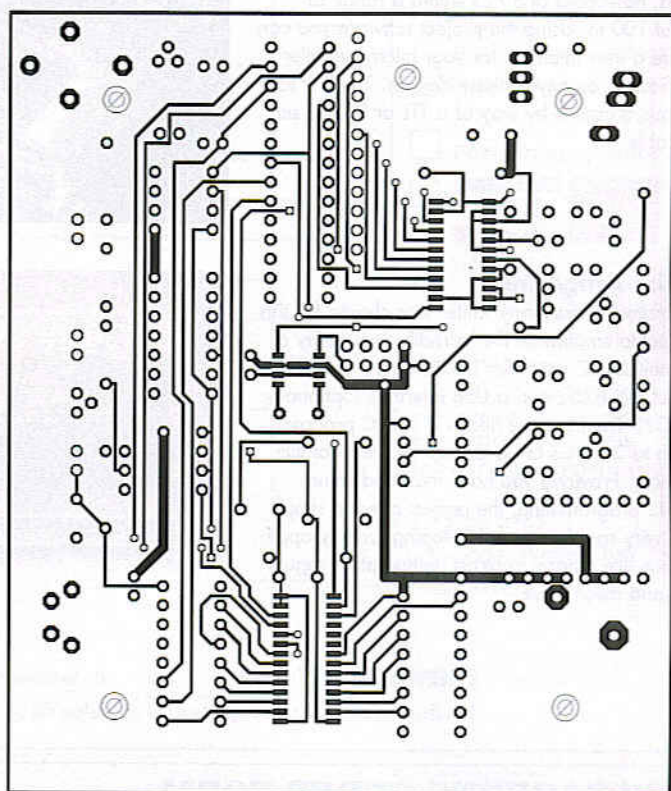

TV Commercials Killer 040051-1 (component side)

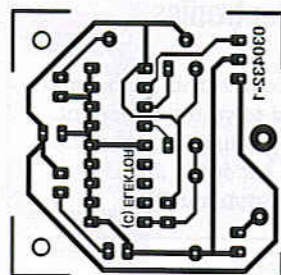

Canon EOS Cameras go Wireless (transmitter) 030432-1

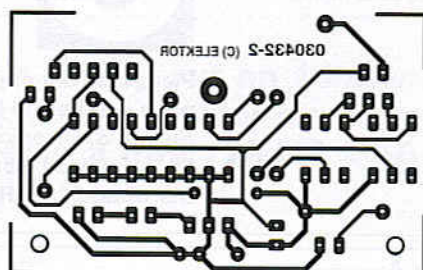

Canon EOS Cameras go Wireless (receiver) 030432-2

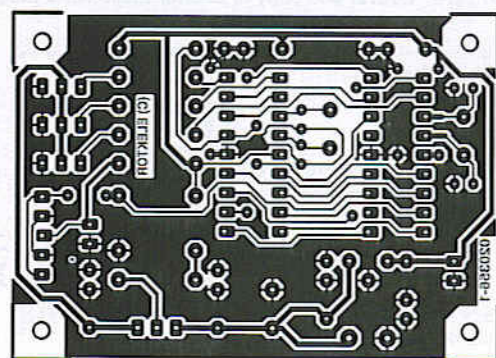

IR Servo Motor Interface for RCX 020356-1

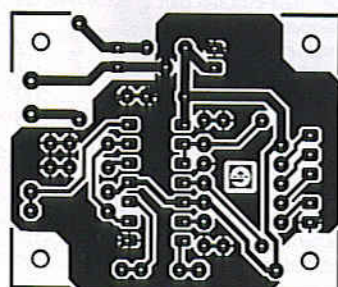

PWM Modulator 044040-1

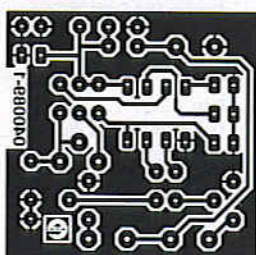

Intelligent Flickering Light 040089-1

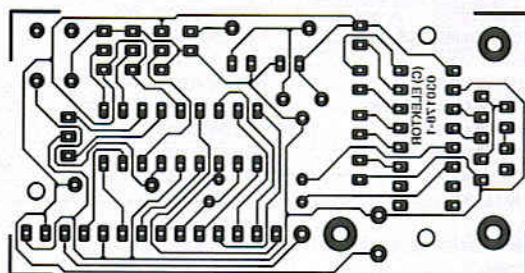

R/C Analyser 030178-1

All PCB layouts shown reflected and at true size (100%) unless otherwise stated.

Bluetooth for Microcontrollers

This multi-purpose module and associated software allows a microcontroller system to communicate with Bluetooth devices like mobile phones, PDAs, notebooks and PCs within a range of about 100 m. Using the project software you can create a user interface for your microcontroller application on any of these devices. The link to the micro itself is by way of a TTL or RS232 serial cable.

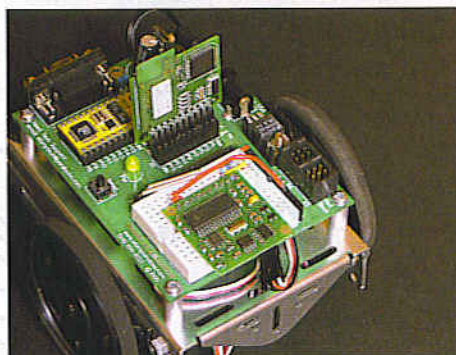

Swiss Army Knife

The name 'Swiss Army Knife' was chosen for this project to emphasize the incredible versatility of a small BASIC controller board based around an Atmel 89C8252 and a USB interface (optionally: RS232). The interface allows a BASIC program of up to 2 kBytes to be loaded into non-volatile memory. Provided you have mastered some BASIC programming, the project offers a simple and very rapid way of developing turnkey applications like alarms, controls, temperature regulators and much more.

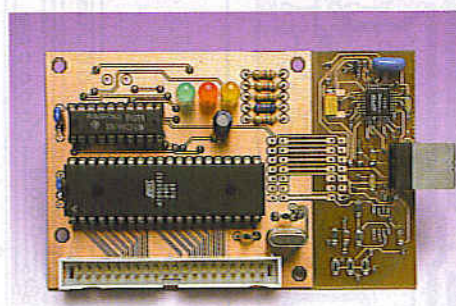

Clarity 300-watt Class-T Amplifier

After the first article instalment in the June 2004 issue we're ready to continue with the construction of this awesome amplifier.



Also...

- Wireless USB Module
- Working with the PIC18F Series
- SMD Dice
- Room Thermometer
- Inside out: Body Fat Meters
- Update: Microcontrollers in the Market
- Mini Project: Slave Flash for Digital Cameras

RESERVE YOUR COPY NOW!

UK subscribers will receive the magazine a few days before this date.

The September 2004 issue goes on sale on Friday 20 August 2004 (UK distribution only).

Article titles and magazine contents subject to change.

NEWSAGENTS ORDER FORM

SHOP SAVE / HOME DELIVERY

Please save / deliver one copy of *Elektor Electronics* magazine for me each month

Name:
 Address:
 Post code:
 Telephone:
 Date:
 Signature:



**elektor
electronics**

Please cut out or photocopy this form, complete details and hand to your newsagent. *Elektor Electronics* is published on the third Friday of each month, except in July. Distribution S.O.R. by Seymour (NS).

INDEX OF ADVERTISERS

Allgood Technology, Net Links www.allgoodtechnology.com 126	London Electronics College, Net Links www.lec.org.uk 126
Beta Layout, Net Links www.pcb-pool.com 101, 126	Matrix Multimedia Ltd www.matrixmultimedia.co.uk 115
BK Electronics www.bkelec.com 135	Milford Instruments www.milinst.demon.co.uk 123
Burn Technology LTD, Net Links www.burntec.com 126	MQP Electronics, Net Links www.mqpelectronics.co.uk 126
CMS www.cms.uk.com 19	Net Links 126, 127
Compucut, Net Links www.compucutters.com 126	New Wave Concepts, Net Links www.new-wave-concepts.com 126
Compulogic www.compulogic.info 101	Number One Systems www.numberone.com 95
Conford Electronics, Net Links www.confordelec.co.uk 126	PAGM www.pagm.co.uk 2
Cricklewood 19	PCB World, Net Links www.pcbworld.org.uk 126
Danbury, Net Links www.mc-h.demon.co.uk 126	Peak Electronic, Net Links www.peakelec.co.uk 127
Debug Innovations, Net Links www.debuginnovations.com 126	Pico www.drdaq.com 125
Display Electronics www.distel.co.uk 105	Quasar Electronics, Net Links www.quasarelectronics.com 3, 127
Easysync, Net Links www.easysync.co.uk 126	Robot Electronics, Net Links www.robot-electronics.co.uk 127
Elexol, Net Links www.elexol.com 126	Stewart of Reading www.stewart-of-reading.co.uk 128
Elnec, Net Links www.elnec.com 126	Technobots, Net Links www.technobots.co.uk 127
Ennovi www.ennovi.co.uk 128	Telnet, Net Links www.telnet.uk.com 127
Ervan International, Net Links www.ervan-int.com 126	Ultraleds, Net Links www.ultraleds.co.uk 127
Eurocircuits www.thepcbshop.com 129	USB Instruments, Net Links www.usb-instruments.com 127
Forest, Net Links www.fored.co.uk 126	Viewcom, Net Links www.viewcom.f9.co.uk 127
Future Technology Devices, Net Links www.ftdichip.com 126			
Futurlec, Net Links www.futurlec.com 126			
Hammond Electronics, Net Links www.hammondmfg.com 126			
Hitex www.hitex.co.uk 115			
ITP www.itp101.com 19			
Komcard, Net Links www.komcard.com 126			
Labcenter www.labcenter.co.uk 136			

ADVERTISING SPACE for the issue of 21 September 2004 may be reserved not later than 25 August 2004 with Elektor Electronics (Publishing) Advertisement Office – 3 Crescent Terrace – Cheltenham GL50 3PE – England – Telephone 01242 510 760 – Fax 01242 226 626 – e-mail: bernardhubbard@ukonline.co.uk to whom all correspondence, copy instructions and artwork should be addressed.

ORDERING INSTRUCTIONS, P&P CHARGES

Except in the USA and Canada, all orders, except for subscriptions (for which see below), must be sent BY POST or FAX to our Tunbridge Wells address using the Order Form overleaf. On-line ordering: <http://www.elektor-electronics.co.uk>

Readers in the USA and Canada may (but are not obliged to) send orders, except for subscriptions (for which see below), to the USA address given on the order form. Please apply to Old Colony Sound for applicable P&P charges. Please allow 4-6 weeks for delivery.

Orders placed on our Tunbridge Wells office must include P&P charges (Priority or Standard) as follows:

UK: £3.50 Europe: £5.00 (Standard) or £7.00 (Priority) Outside Europe: £8.00 (Standard) or £12.00 (Priority)

HOW TO PAY

Unless you have an approved credit account with us, all orders must be accompanied by the full payment, including postage and packing charges as stated above. Payment may be made by cheque drawn on a London clearing bank (but see para. 4 below), postal order, VISA, Access, MasterCard or EuroCard (when paying by credit card, the order must go the cardholder's address). Do not send cash through the mail. Cheques and postal orders should be crossed and made payable to 'Elektor Electronics (Publishing)'. Payment may also be made by direct transfer from a private or business Giro account to our **Giro account No. 34 152 3801** by completing and sending to the National Giro Centre, in a National Giro postage paid envelope, a National Giro transfer/deposit form. Do not send Giro transfers direct to us, as this will delay your order. If you live outside the UK, payment may also be made by Bankers' sterling draft drawn on a London clearing bank, Eurocheque made out in pounds sterling (with holder's guarantee card number written on the back), or US or Canadian dollar cheque drawn on a US or Canadian bank. If you pay by Bankers' sterling draft, make clear to the issuing bank that your full name and address MUST be communicated to the London clearing bank. Our bankers are **NAT WEST PLC, 1 St James's Square, Wadhurst, East Sussex TN5 6BH, England. Our account number is 3512 5225, Sorting Code 60-22-15. IBAN code: GB40 NWB K6 022 15 3512 5225 BIC code: NWB KGB 2L**

COMPONENTS

Components for projects appearing in Elektor Electronics are usually available from certain advertisers in this magazine. If difficulties in the supply of components are envisaged, a source will normally be advised in the article. Note, however, that the source(s) given is (are) not exclusive.

TERMS OF BUSINESS

Delivery Although every effort will be made to dispatch your order within 2-3 weeks from receipt of your instructions, we can not guarantee this time scale for all orders. **Returns** Faulty goods or goods sent in error may be returned for replacement or refund, but not before obtaining our consent. All goods returned should be packed securely in a padded bag or box, enclosing a covering letter stating the dispatch note number. If the goods are returned because of a mistake on our part, we will refund the return postage. **Damaged goods** Claims for damaged goods must be received at our Tunbridge Wells office within 10 days (UK); 14 days (Europe) or 21 days (all other countries). **Cancelled orders** All cancelled orders will be subject to a 10% handling charge with a minimum charge of £5.00. **Patents** Patent protection may exist in respect of circuits, devices, components, and so on, described in our books and magazines. Elektor Electronics (Publishing) does not accept responsibility or liability for failing to identify such patent or other protection. **Copyright** All drawings, photographs, articles, printed circuit boards, programmed integrated circuits, diskettes and software carriers published in our books and magazines (other than in third-party advertisements) are copyright and may not be reproduced or transmitted in any form or by any means, including photocopying and recording, in whole or in part, without the prior permission of Elektor Electronics (Publishing) in writing. Such written permission must also be obtained before any part of these publications is stored in a retrieval system of any nature. Notwithstanding the above, printed-circuit boards may be produced for private and personal use without prior permission. **Limitation of liability** Elektor Electronics (Publishing) shall not be liable in contract, tort, or otherwise, for any loss or damage suffered by the purchaser whatsoever or howsoever arising out of, or in connexion with, the supply of goods or services by Elektor Electronics (Publishing) other than to supply goods as described or, at the option of Elektor Electronics (Publishing), to refund the purchaser any money paid in respect of the goods. **Law** Any question relating to the supply of goods and services by Elektor Electronics (Publishing) shall be determined in all respects by the laws of England.

January 2004

SUBSCRIPTION RATES FROM JANUARY 2004 ISSUE

	Standard	Plus
United Kingdom	£39.50	£45.50
Economy Mail		
Rest of the World (excluding Europe)	£51.30	£57.30
Priority Airmail		
Europe & Eire	£52.50	£58.50
Middle East, Africa, Southwest Asia, Central & South America	£64.00	£70.00
Australia, New Zealand, Far East & Pacific Territories	£66.00	£72.00
Airfreight		
USA & Canada only	US\$88.00	US\$96.50

Payment should be made by:

- Cheque or bankers' draft in sterling drawn on a London clearing bank (except in the USA and Canada — see below);
- US\$ cheques drawn on a US or Canadian bank — only by subscribers in the USA or Canada.
- Direct transfer to our bank (NAT WEST PLC, 1 St James's Square, Wadhurst, East Sussex TN5 6BH, England). Our account number is 3512 5225, Sorting Code 60-22-15. IBAN code: GB40 NWB K6 022 15 3512 5225 BIC code: NWB KGB 2L
- Postal order.
- Credit card: VISA, ACCESS, Euro/MasterCard, JCB Electron or Switch.
- Transfer to our Giro Account number 34 152 3801. Giro transfers should be made by completing and sending the appropriate transfer/deposit form to the National Giro Centre (UK) or to your national Giro Centre.

Cheques and postal orders should be made payable to Elektor Electronics (Publishing). Do not send cash through the mail.

SUBSCRIPTION RATES FOR 18-MONTH SUBSCRIPTION

	Standard	Plus
United Kingdom	£59.25	£65.25
Economy Mail		
Rest of the World (excluding Europe)	£76.95	£82.95
Priority Airmail		
Europe & Eire	£78.75	£84.75
Middle East, Africa, Southwest Asia, Central & South America	£96.00	£102.00
Australia, New Zealand, Far East & Pacific Territories	£99.00	£105.00
Airfreight		
USA & Canada only	US\$132.00	US\$140.50

SUBSCRIPTION CONDITIONS

The standard subscription order period is twelve months. If a permanent change of address during the subscription period means that copies have to be despatched by a more expensive service, no extra charge will be made. Conversely, no refund will be made, nor expiry date extended, if a change of address allows the use of a cheaper service. Student applications, which qualify for a 20% (twenty per cent) reduction in current rates, must be supported by evidence of studentship signed by the head of the college, school or university faculty. A standard Student Subscription costs £31.60, a Student Subscription-Plus costs £37.60 (UK only). Please note that new subscriptions take about four weeks from receipt of order to become effective. Cancelled subscriptions will be subject to a charge of 25% (twenty-five per cent) of the full subscription price or £7.50, whichever is the higher, plus the cost of any issues already dispatched. Subscriptions cannot be cancelled after they have run for six months or more.

January 2004



Try us for Tivoli Radio
Tivoli Radio 1 Just £91.95 Carriage £8.00

OMP MOS-FET POWER AMPLIFIERS

HIGH POWER, TWO CHANNEL 19 INCH RACK

10,000's
SOLD
TO PRO
USERS



THE RENOWNED MXF SERIES OF POWER AMPLIFIERS

FOUR MODELS:- MXF200 (100W + 100W) MXF400 (200W + 200W)
MXF600 (300W + 300W) MXF900 (450W + 450W)

ALL POWER RATINGS ARE R.M.S. INTO 4 OHMS, WITH BOTH CHANNELS DRIVEN
FEATURES:- * Independent power supplies with two toroidal transformers
* Twin L.E.D. Vu Meters * Level controls * Illuminated on/off switch * Jack / XLR inputs
* Speakon Outputs * Standard 775mv inputs * Open and Short circuit proof * Latest Mos-Fets
for stress free delivery into virtually any load * High slew rate * Very low distortion * Aluminium
cases * MXF600 & MXF900 fan cooled with D.C. Loudspeaker and thermal protection

USED THE WORLD OVER IN CLUBS, PUBS, CINEMAS, DISCOS ETC

SIZES:-
MXF200 W19" D11" H3 1/2" (2U)
MXF400 W19" D12" H5 1/2" (3U)
MXF600 W19" D13" H5 1/2" (3U)
MXF900 W19" D14" H5 1/2" (3U)

PRICES:- MXF200 £175.00 MXF400 £233.85
MXF600 £329.00 MXF900 £449.15
SPECIALIST CARRIER DEL £12.50 Each



ABSOLUTE HIGH END CLASS D AMPLIFIER

The OMP MFD600 can be used as a stand alone monoblock amplifier or fitted into existing loudspeakers to make them active

- Compact design due to switch mode P.S.U.
- 90% Efficient high switching frequency
- Small size, fits in a 110mm x 92mm opening
- Neutrik® Combi input balanced / unbalanced
- Output fully protected
- Status LEDs - Presence / Clip / Protect
- 600W / 2 Ohm - 500W / 4 Ohm - 300W / 8 Ohm
- All powers in R.M.S.
- Volume control. Input sensitivity 775mV
- Freq. Response 2Hz-20kHz
- Light weight 3kg

Stunning performance
Audiophile Quality

For further information please look at our website at www.bkelec.com and click on the modules and hybrids button

Special quantity pricing and customised artwork for OEM's.

Price £281.12 Inc Vat Each or £499.00 Per Pair when quoting this advert

Carriage UK Mainland Only £8.00



50W to 500 WATT ACTIVE SUB BASS AMPLIFIER PANELS



The BSB Range of Sub Bass Amplifiers consists of 5 panels with power outputs of 50W to 500W to suit most of the DIY enthusiasts needs. All panels are airtight and come equipped with both high and low level inputs with separate gain controls, frequency adjust and 0-180 Deg. continuous phase control adjustment. A full connection lead pack included

MODEL	PRICE	IMP.	* Please
BSBP50	£89.95	8 Ohm	State 4
BSBP100	£117.44	*4/8 Ohm	or 8 Ohm
BSBP200	£149.50	*4/8 Ohm	when
BSBP300	£184.50	4 Ohm	ordering
BSBP500	£219.50	4 Ohm	

Model Shown:- BSBP200

SPECIFICATIONS:- * POWER 200W RMS @ 4 or 8 OHMS * FREQ RESP. 10Hz 15KHz
-3dB * DAMPING FACTOR >200 * DISTORTION 0.05% * S/N A WEIGHTED >100dB *
SUPPLY 230V A.C. * WEIGHT 5.0kg * SIZE H254 X W254 X D95mm

THERE ARE 2 VERSIONS OF THE ABOVE PANEL AVAILABLE :-BSB200/8
8 OHM VERSION BSB200/4 4 OHM VERSION CHECK WEBSITE FOR PANELS UP TO 500W



DELIVERY CHARGES:- PLEASE INCLUDE AS ABOVE. A MINIMUM CHARGE OF £8.00 TO A MAXIMUM AMOUNT OF £30.00. OFFICIAL ORDERS FROM SCHOOLS, COLLEGES, GOVT. PLCs ETC. PRICES INCLUSIVE OF V.A.T. SALES COUNTER. CREDIT CARD ORDERS ACCEPTED BY POST PHONE OR FAX.



XLS 200 Subwoofer Sytem

Save £100's buying factory direct



We have combined the famous Peerless XLS10 with our renowned BSBP200/4 sub bass panel in a compact MDF cabinet that measures only D390 x H295 x W295 to produce a truly awesome sub woofer system suitable for both Hi-Fi and AV use.

Customer Comment:- It sounds excellent, how did I live without one before. Its opened up the sound on the whole system and given it a more "full" sound. I thought my speaker set up was good before but now it's awesome.

Features:- *High and low level inputs *Frequency adjust *Continuous phase control *200W RMS *Separate control of high and low level gain *Automatic Speaker Protection. Comes complete with mains lead, 5m stereo phono lead, 10m High level lead and Spikes

Available in Silver or Black, for further information please look on our website at <http://www.bkelec.com>

£279.00 Each plus £8.00 carriage within the UK mainland. International carriage charges to Germany, France, Belgium, Luxembourg and Holland at only £16.00 per XLS200

MXF1200D 600W Per Channel Class D

Price:- 469.95 Inc. V.A.T. Carriage £8.00



The MXF1200D is not only a must for PA and Disco use, but it's stunning performance lends itself readily to Studio and High Power AV Cinema installs, it is also suitable for Hi-End Hi-Fi use. Can be driven direct from a CD player and has balanced XLR input, unbalanced jack input.

The latest in high-tech Class D amplifiers coupled to two independent switch-mode power supplies. Front Panel:- Presence Led's, Clip Led's, Independent volume controls and power On/Off switch with cool blue illuminated surrounds. Rear Panel:- Mains IEC input, Neutrik Speakon outputs and Neutrik Combi inputs

Golf Ball Height



Specification:- Output power 600W RMS into 2 Ohm, 500W RMS into 4 Ohm, 300W RMS into 8 Ohm Frequency response 2 Hz to 22kHz, Input sensitivity 775mV, Input Imp.7.5k Ohms, T.H.D. 0.1%, S/N 85dB, Power Supply 230V AC 50Hz, Switching Freq. 450kHz, Weight 8.0kg, Size H44 x W482 x L376mm

OMP MOS-FET POWER AMPLIFIER MODULES

SUPPLIED READY BUILT AND TESTED

These modules now enjoy a world-wide reputation for quality, reliability and performance at a realistic price. Four models are available to suit the needs of the professional and hobby market i.e. Industry, Leisure, Instrumental and Hi-Fi etc. When comparing prices, NOTE that all models include toroidal power supply, integral heatsink, glass fibre P.C.B. and drive circuits to power a compatible Vu meter. All models are open and short circuit proof

THOUSANDS OF MODULES PURCHASED BY PROFESSIONAL USERS



OMP/MF 100 Mos-Fet Output Power 110 watts R.M.S. into 4 ohms, frequency response 1Hz - 100kHz -3dB, Damping Factor >300, Slew Rate 45V/uS, T.H.D. typical 0.002%, Input Sensitivity 500mV, S.N.R. 110dB, Size 300 x 123 x 60mm.
Price:- £43.85 + £4.00 P&P



OMP/MF 200 Mos-Fet Output Power 200 watts R.M.S. into 4 ohms, frequency response 1Hz - 100kHz -3dB, Damping Factor >300, Slew Rate 50V/uS, T.H.D. typical 0.001%, Input Sensitivity 500mV, S.N.R. 110dB, Size 300 x 155 x 100mm.
Price:- £67.35 + £4.00 P&P



OMP/MF 300 Mos-Fet Output Power 300 watts R.M.S. into 4 ohms, frequency response 1Hz - 100kHz -3dB, Damping Factor >300, Slew Rate 60V/uS, T.H.D. typical 0.001%, Input Sensitivity 500mV, S.N.R. 110dB, Size 330 x 175 x 100mm.
Price:- £84.75 + £5.00 P&P



OMP/MF 450 Mos-Fet Output Power 450 watts R.M.S. into 4 ohms, frequency response 1Hz - 100kHz -3dB, Damping Factor >300, Slew Rate 75V/uS, T.H.D. typical 0.001%, Input Sensitivity 500mV, S.N.R. 110dB, Fan Cooled, D.C. Loudspeaker Protection, 2 Second Anti Thump Delay, Size 385 x 210 x 105mm.
Price:- £137.85 + £6.00 P&P



OMP/MF 1000 Mos-Fet Output Power 1000 watts R.M.S. into 2 ohms, frequency response 1Hz - 100kHz -3dB, Damping Factor >300, Slew Rate 75V/uS, T.H.D. typical 0.001%, Input Sensitivity 500mV, S.N.R. 110dB, Fan Cooled, D.C. Loudspeaker Protection, 2 Second Anti Thump Delay, Size 422 x 300 x 125mm.
Price:- £264.00 + £12.00 P&P

NOTE: MOS-FET MODULES ARE AVAILABLE IN TWO VERSIONS. STANDARD - INPUT SENS 500mV/BANDWIDTH 100kHz OR PEC (PROFESSIONAL EQUIPMENT COMPATIBLE) - INPUT SENS 775mV, BANDWIDTH 50kHz. ORDER STANDARD OR PEC

Peerless XLS10 Sub Woofer Driver



The renowned Peerless XLS10 Drive unit is possibly one of the best 10 inch sub woofer drivers available today. Made in Denmark by Peerless, a company synonymous with quality and craftsmanship. This drive unit is ideal for inclusion into small enclosures of around 17 litres and will give a tight controlled deep bass output. To further enhance the qualities of this unit greater output and deeper bass can be achieved by coupling the XLS10, with it's companion passive radiator the XLS10P

Peerless XLS 10 £89.00. Peerless XLS10P 32.90 Carriage £8.00

For full specification and prices goto our website at <http://www.bkelec.com> and try our new shopping basket facility

B.K. ELECTRONICS REF EL2

UNIT 1 COMET WAY, SOUTHEND-ON-SEA, ESSEX, SS2 6TR.
TEL.: 01702-527572 FAX.: 01702-420243
Web:- <http://www.bkelec.com> E-Mail sales@bkelec.com

PROTEUS

The Complete Electronics Design System

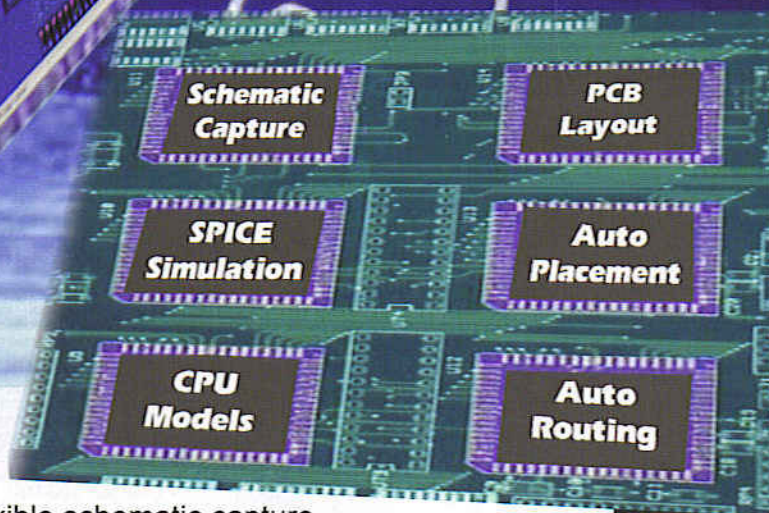
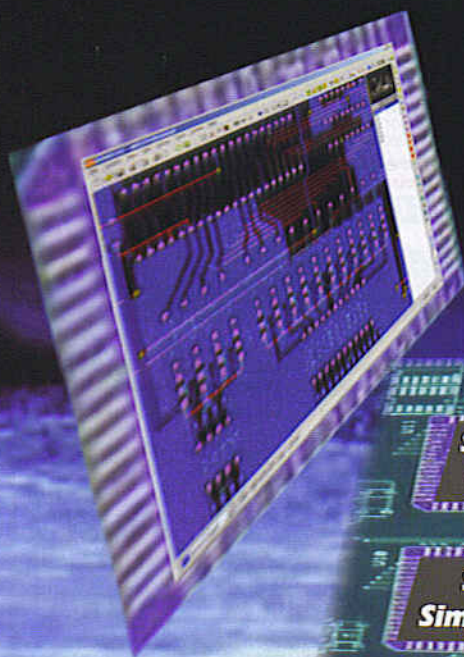

VSM

Virtual System Modelling

Schematic & PCB Layout

- Powerful & flexible schematic capture.
- Auto-component placement and rip-up/retry PCB routing.
- Polygonal gridless ground planes.
- Libraries of over 8000 schematic and 1000 PCB parts.
- Bill of materials, DRC reports and much more.

Mixed Mode SPICE Circuit Simulation

- Berkeley SPICE3F5 simulator with custom extensions for true mixed mode and interactive simulation.
- 6 virtual instruments and 14 graph based analysis types.
- 6000 models including TTL, CMOS and PLD digital parts.
- Fully compatible with manufacturers' SPICE models.

Proteus VSM - Co-simulation and debugging for popular Micro-controllers

- Supports PIC, AVR, 8051, and BASIC STAMP micro-controllers.
- Co-simulate target firmware with your hardware design.
- Includes interactive peripheral models for LED and LCD displays, switches, keypads, virtual terminal and much, much more.
- Compatible with popular compilers and assemblers from Microchip, Crownhill, IAR, Keil, and others.

New Features in Version 6.5

- Textual library part search.
- User defined keyboard map.
- CAD/CAM output to ZIP file.
- Bitmap import function.
- Truetype fonts on PCBs.
- Enhanced printer output.

Call Now for Upgrade Pricing

labcenter
Electronics
53-55 Main Street, Grassington. BD23 5AA

Tel: 01756 753440
Fax: 01756 752857

Contact us for
Free Demo CD

NEW
ELECTRA
SHAPE BASED
AUTOROUTER
NOW AVAILABLE

www.labcenter.co.uk
info@labcenter.co.uk